

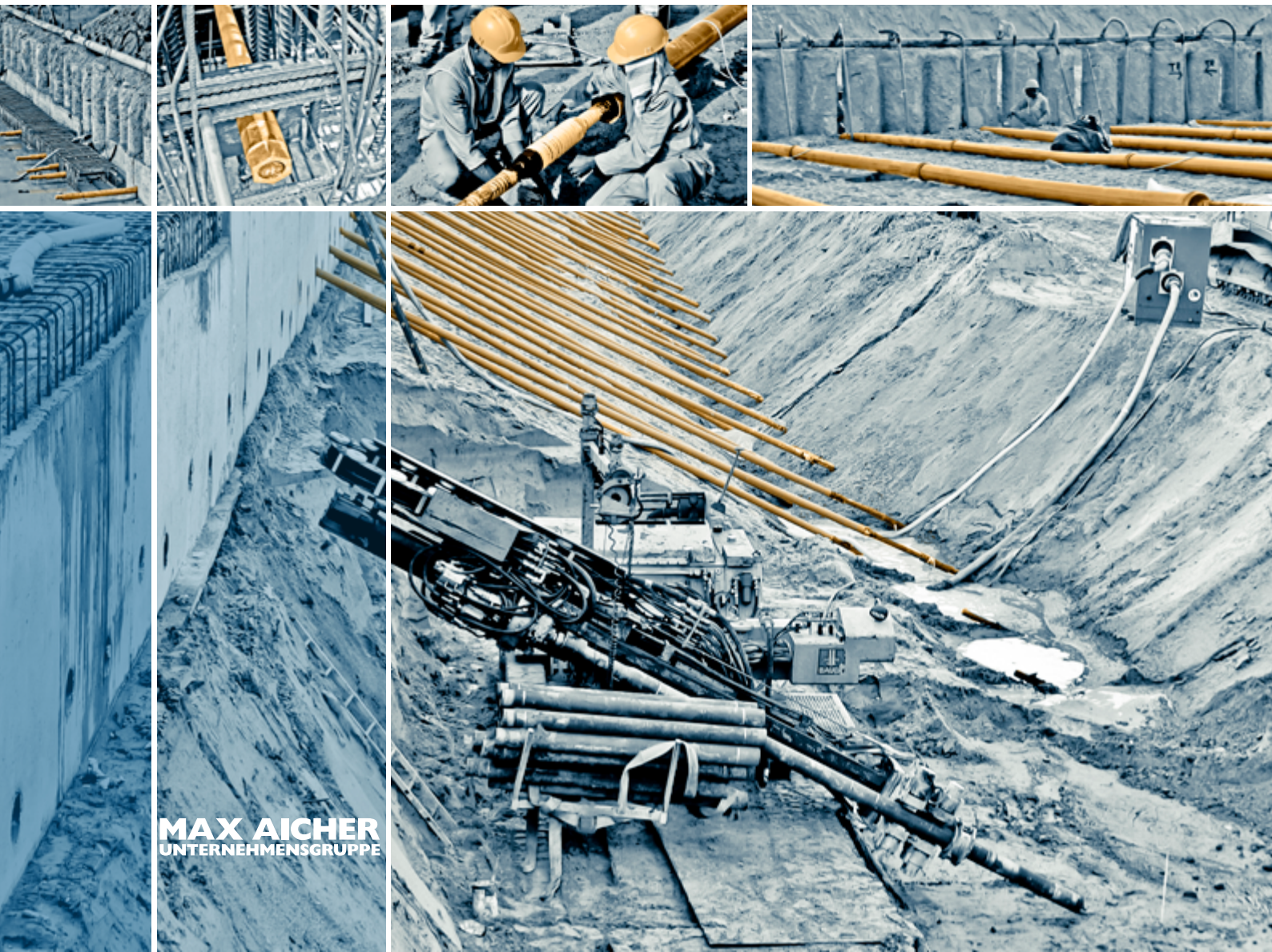

SAH
Stahlwerk Annahütte

SAS Marine Tie

SAS SYSTEMS



MAX AICHER
UNTERNEHMENSGRUPPE

Inhaltsverzeichnis

Table of Contents

Einleitung.....	3
<i>Introduction</i>	
SASZuganker.....	4
<i>SAS Tie rods</i>	
SASBohrverpressanker.....	5
<i>SAS Ground anchor</i>	
SAH Gewindestäbe Produktprogramm.....	5
SAH Threadbars productprogramm	
Zugfestigkeit von Zugankern.....	6
Tensile resistance of tie rods	
SAS Zuganker Zubehör.....	8
SAS Tie rods accessories	
Standardanschlüsse an Spundwände.....	15
standard connections to sheet pile walls	
Gurtungen.....	18
walings	
Gurtkonsolen.....	18
waling consoles	
Gurtstoßausbildung.....	19
waling construction	
Gurtbolzen.....	20
waling bolts	
Gurtbolzen mit Kopf und Mutter.....	21
Waling bolts with head and nut	
Gurtbolzen mit zwei Muttern.....	21
Waling bolts with two nuts	
Beispiele für Gurtungen.....	22
examples for walings	
Kantenpoller.....	23
edge bollards	
Haltepoller.....	24
mooring bollards	
Verankerung für Poller.....	25
anchorages for bollards	
Korrosionsschutzsysteme.....	26-28
Corrosion protection systems	
Bemessungsbeispiel SAS Zuganker nach EAU 2014.....	29
Design example SAS Tie rods acc. to EAU 2014	
Bemessungsbeispiel Bohrverpressanker.....	31
Design example ground anchor	
SASGewindestäbe.....	32
SAS thread bars	

Stahlwerk Annahütte Max Aicher GmbH & Co. KG gegründet im Jahr 1537 vom Salzburger Fürsterzbischof Matthäus Lang von Wellenburg ist das Stahlwerk Annahütte das älteste Stahlwerk Europas. Im Stahlwerk Annahütte werden Gewindestähle für die Bauindustrie und Stabstähle für die Automobil- und Werkzeugindustrie mit garantiert hoher Qualität hergestellt. Verschiedene Fertigungsstufen und Produktionsprozesse ermöglichen eine große Vielzahl von Stahlqualitäten in unterschiedlichen Durchmessern. Zulassungen für Gewindestähle, Zubehörteile und Systeme ermöglichen einen weltweiten Einsatz der Produkte des Stahlwerks Annahütte.

Stahlwerk Annahütte Max Aicher GmbH & Co. KG founded in the year 1537 from Matthäus Lang von Wellenburg the Prince-Archbishop of Salzburg, Stahlwerk Annahütte is the oldest steel mill in Europe. With guaranteed high quality thread bars for the construction industry and steel bars for the automobile and tool industry are produced. Different stages of production and processes allow a wide range of steel qualities and diameters. Approvals for thread bars, accessories and systems support a worldwide use of the products of Stahlwerk Annahütte.



Speziell für das Anwendungsgebiet Hafenanbau bzw. Wasserbau des konstruktiven Ingenieurbaus liefern wir SAS Gewindestäbe und entsprechendes Zubehör. Abgestimmt mit einem optimierten Korrosionsschutzsystem können SAS Gewindestahlssysteme für den Hafenanbau in allen Umgebungsbedingungen eingesetzt werden. Das vorliegende Handbuch unterstützt den Anwender in der Praxis und bietet Empfehlungen für Bemessung und Konstruktion.

Especially for the marine tie application of the structural civil engineering we deliver SAS thread bars and accessories. With adjustment of an optimal corrosion protection SAS thread bar systems can be installed for the marine tie application in every environment. This manual is for technicians or engineers and presents recommendations for the design and construction.

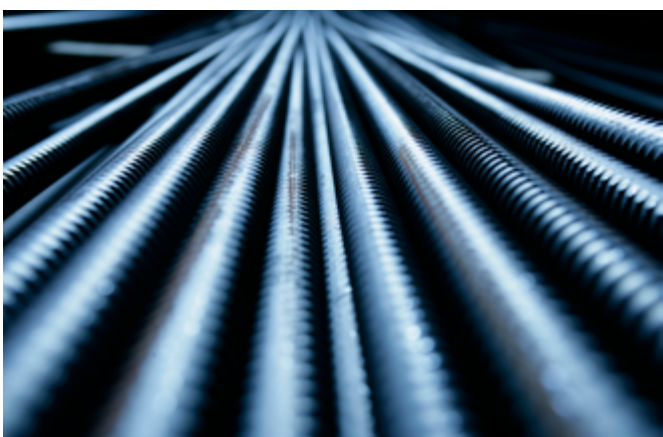

SAS Zuganker

SAS tie rods

Für das Anwendungsgebiet Hafen- und Wasserbau werden SAS Gewindestäbe als Zuganker (horizontale Zugglieder in Verbindung mit einer Ankerwand) oder Bohrverpressanker z.B. für Spundwandrück Verankerungen eingesetzt. Die mechanisch technologischen Eigenschaften der SAS Gewindestäbe sind unten stehend tabellarisch dargestellt. Das über die gesamte Länge verlaufende Grobgewinde ermöglicht ein universelles Koppeln und Verlängern der eingesetzten Zuganker.

SAS Gewindestäbe sind aus der Walzhitze wärmebehandelte Stähle mit Gewinderippen. Aufgrund des im Warmwalzprozess hergestellten Grobgewindes über die gesamte Ankerlänge kann die volle Tragfähigkeit über den Querschnitt angesetzt werden. Eine Reduzierung der Zugkraftbeanspruchbarkeit der SAS Zuganker durch einen Kerbfaktor ist nicht erforderlich.

Signifikante Gewichtseinsparungen, geringere Materialkosten oder Einsparungen in den Frachtkosten sind nur einige der Vorteile von SAS Zugankern.

For marine tie application SAS thread bars are used as tie rods (horizontal tie rods in connection with a wall) or ground anchors for example for the sheet pile wall construction. The mechanical technological properties of SAS thread bars are listed in the table. Due to the coarse thread over the total length, cutting and coupling at any length of the installed tie rods is possible

SAS thread bars are heat treated bars with thread ribs. Because of the hot-rolling process of the bars with the thread ribs over the total length of the tie rods, the full load bearing capacity over the cross section can be taken for designing. A reduction of the tension strength with a notch factor.

Significant savings of the weight, lower material costs or savings of the freight costs are just some of the advantages of SAS tie rods.

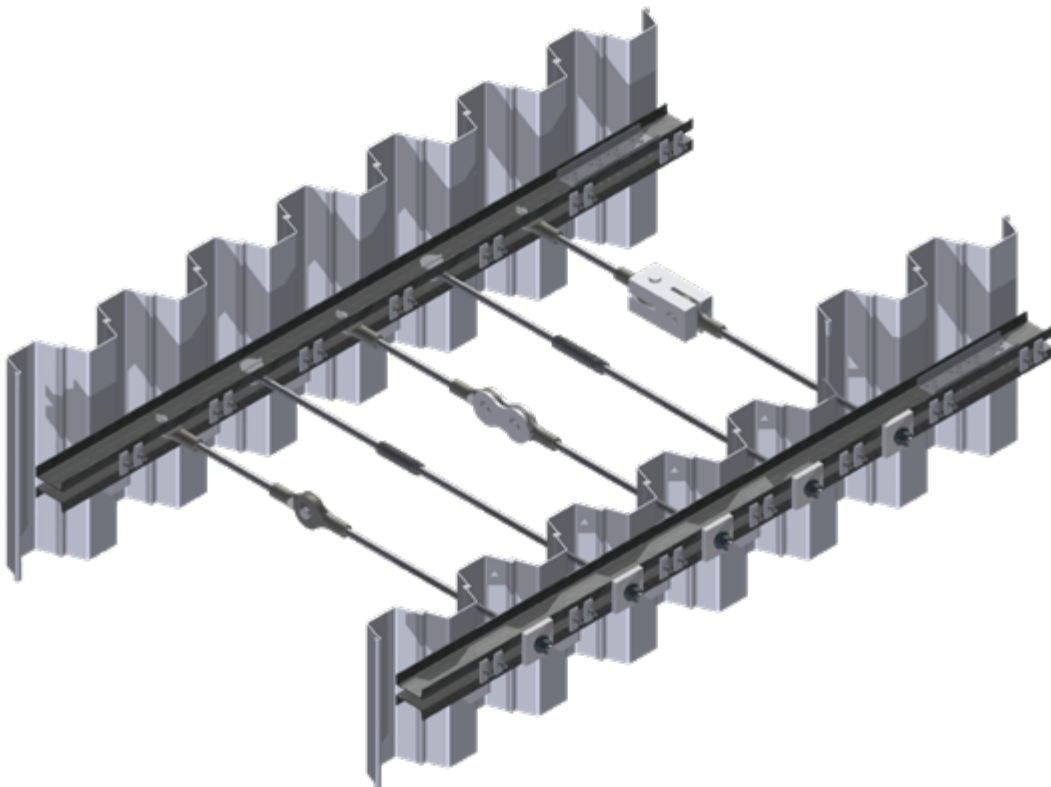

SAS Bohrverpressanker

SAS ground anchor

Ein Bohrverpressanker besteht aus einem Ankerkopf und dem Stahlzugglied, welches wiederum aus einer Verankerungslänge und einer Freispielstrecke mit Verpresskörper besteht. Der Verpresskörper überträgt eine aufgebrauchte Zugkraft auf eine tragfähige Schicht im Baugrund.

Am unteren Ende ist der Bohrverpressanker durch eingepressten Zementmörtel, dem Verpresskörper, verankert. Am luftseitigen Ende wird die Konstruktion über einen Ankerkopf vorgespannt

A ground anchor consists of an anchor head, a tension rod, which consist of a free and a bond length with a cement grout body. The cement grout body transfers the applied load into a stable soil or rock layer.

The bottom of the ground anchor is anchored by the cement grout. At the top the ground anchor is pre-stressed by the anchor head, which is retaining by the anchored construction.



SAH Gewindestäbe Produktprogramm für Hafenanwendungen

SAH threadbars productprogramm für marine tie application

Typ / type	Durchmesser / Diameter	Streckgrenze / yield stress	Zugfestigkeit / ultimate stress
	[mm]	[N/mm ²]	[N/mm ²]
SAS 500 (BSt 500 S) / grade 75	20 - 25 - 28 - 32 - 40 - 50 - 75	500	550
SAS 555 / 700 / grade 80	57,5 - 63,5	555	700
SAS 670 / 800 / grade 97	18 - 22 - 25 - 28 - 30 - 35 - 43 - 50 - 57,5 - 63,5 - 75	670	800

Zugfestigkeit von Zugankern

Tensile resistance of tie rods

Entsprechend der DIN EN 1993-5 (EC3) und der EAU 2014 E20 („Empfehlungen des Arbeitsausschusses „Ufereinfassungen, Häfen und Wasserstraßen“) berechnet sich die Zugfestigkeit des Zugankers ($F_{t', Rd}$) aus dem Minimum, aus der Zugfestigkeit aus dem Gewinde ($F_{tt', Rd}$) und der Zugfestigkeit aus dem Schaft ($F_{tg', Rd}$).

In accordance with der DIN EN 1993-5 (EC3) an the EAU 2014 E20 (“Recommendations of the Committee for „Waterfront Structures, Harbours and Waterways“) the tensile resistance of a tie rod ($F_{t', Rd}$) is calculated as the minimum of the tensile resistance of the thread part ($F_{tt', Rd}$) and the tensile resistance of the shaft ($F_{tg', Rd}$).

$F_{t', Rd}$ = minimum of :



$$F_{tg', Rd} = A_g \times f_y / \gamma_{m0}$$

$$F_{tt', Rd} = k_t \times f_{ua} \times A_s / \gamma_{m2}$$

- A_g = Bruttoquerschnittsfläche des Ankers / gross cross sectional area of anchor
- A_s = Zugspannungsbereich der Gewinde / tensile stress area of thread
- f_y = Streckgrenze / yield strength
- f_{ua} = Zugfestigkeit / ultimate strength
- k_t = Abminderungsfaktor für Kombination Biege Zug im Gewindebereich (0,6 wo mit Biegung im Anschlussbereich gerechnet werden muss und 0,9 wo bauliche Maßnahmen Biegung im Gewindebereich eliminieren) / a reduction factor allowing for combined bending and tension in the thread (typically 0,6 where bending at the connection must be considered and 0,9 where structural detailing eliminates bending at the connections)

$\gamma_{m0} + \gamma_{m2}$ = Sicherheitsfaktoren entspr. DIN EN 1993-5 (1,0 + 1,25) / Safety factors acc. DIN EN 1993-5 (1,0 + 1,25)

Auf Grund der Gewindeherstellung empfiehlt SAH die Verwendung des k_t - Faktors (Kerbfaktor) = 1,0 für alle Ansätze.

Due to the threading SAH recommends using the k_t -factor (notch factor) = 1.0 for all approaches.

Der Einfluss durch Biege Zug auf den SAH Gewindestab unterscheidet sich nicht von dem Einfluss durch Biege Zug auf einen Rundanker. Der k_t -Faktor kann daher vernachlässigt werden.

The influence by bending-tension on the SAH threaded tie rod is no different from the influence by bending-tension on a smooth rod. The k_t -factor can therefore be neglected.

Im Gegensatz zu den üblichen gerollten oder geschnittenen Gewinden haben die SAS Zuganker ein warmgewalztes Gewinde!

Contrary to the usual rolled or cut threads, the SAS tie rods have a hot rolled thread!

Walz- oder Herstellfasern / rolling oder fabrication fibers



Warmgewalztes Gewinde(SAH) / Hot rolled thread

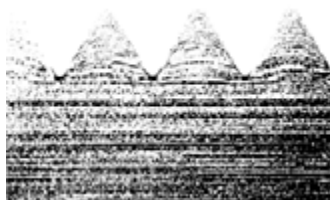

Gerolltes Gewinde / Rolled thread

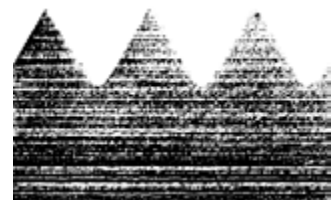

Geschnittenes Gewinde / Cutted thread

Zugfestigkeit von Zugankern

Tensile resistance of tie rods

Streckgrenze / Zugfestigkeit <i>yield stress / ultimate stress</i>	Nenn-Ø <i>nom-Ø</i>	Strecklast <i>yield load</i>	Bruchlast <i>ultimate load</i>	Fläche <i>cross section area</i>	Gewicht <i>weight</i>	Zugfestigkeit <i>Tensile resistance</i>
[N/mm ²]	[mm]	[kN]	[kN]	[mm ²]	[kg/m]	¹⁾ min. (F _{tg'} Rd; F _{tt'} Rd)
SAS 500 / 550 - grade 75						
	20	160	175	314	2,47	140,0
	25	245	270	491	3,85	216,0
	28	310	340	616	4,83	272,0
	32	405	440	804	6,31	352,0
	36	510	560	1.020	7,99	448,0
	40	630	690	1.260	9,87	552,0
	43	726	799	1.452	11,40	639,2
	50	980	1.080	1.960	15,40	864,0
	75	2,209	2.430	4.418	34,68	1944,0
SAS 555 / 700 - grade 97						
	57,5	1.441	1.818	2.597	20,38	1441,0
	63,5	1.760	2.215	3.167	24,86	1760,0
SAS 670 / 800 - grade 97						
	18	170	204	254	2,00	163,2
	22	255	304	380	2,98	243,2
	25	329	393	491	3,85	314,4
	28	413	493	616	4,83	394,4
	30	474	565	707	5,55	452,0
	35	645	770	962	7,55	616,0
	43	973	1.162	1.452	11,40	929,6
	50	1.315	1.570	1.963	15,40	1256,0
	57,5	1.740	2.077	2.597	20,38	1661,6
	63,5	2.122	2.534	3.167	24,86	2027,2
	75	2.960	3.535	4.418	34,68	2828,0

¹⁾ entsprechend DIN EN 1993-5 (EC 3) - EAU 2014 E 20 - k_t = 1,0
acc. DIN EN 1993-5 (EC 3) - EAU 2014 E 20 - k_t = 1,0

Zubehör

accessories

SAS SYSTEMS

Ankermutter
anchor nut

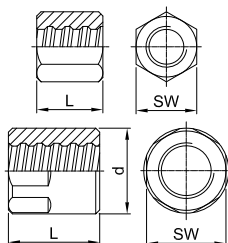

Ø [mm]	T 2002		TR 2002	
	SW x L [mm]	[kg]	SW x L [mm]	[kg]
25	41 x 50	0,34	46 x 55	0,55
26	46 x 50	0,45	---	---
28	46 x 55	0,48	50 x 60	0,69
30	50 x 60	0,65	55 x 65	0,92
32	55 x 60	0,78	---	---
35	---	---	65 x 70	1,41
36	60 x 65	1,00	---	---
40	65 x 70	1,19	---	---
43	70 x 75	1,51	80 x 90	2,76
50	80 x 90	2,17	80 x 100	2,53
57,5	90 x 100 x 102	3,69	90 x 120 x 102	4,53
63,5	100x 115x 108	4,72	100 x 145 x 114	6,98
75	100 x 100 x 108	2,99	100 x 130 x 108	4,00

SAS SYSTEMS

Kugelbundmutter 55°
domed nut 55°

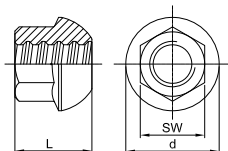
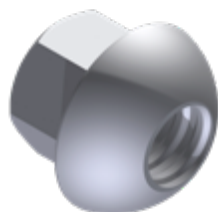

Ø [mm]	T 2044		TR 2001	
	SW x L x d [mm]	[kg]	SW x L x d [mm]	[kg]
25	41 x 45 x 55	0,35	41 x 50 x 60	0,39
26	---	---	---	---
28	41 x 54 x 62	0,45	46 x 55 x 67	0,62
30	---	---	50 x 60 x 71	0,66
32	46 x 57 x 70	0,60	---	---
35	---	---	60 x 70 x 83	1,10
36	---	---	---	---
40	60 x 70 x 88	1,50	---	---
43	70 x 80 x 100	1,94	70 x 85 x 102	2,22
50	80 x 85 x 107	2,80	80 x 100 x 116	3,44
57,5	90 x 100 x 120	3,79	90 x 115 x 137	4,90
63,5	100 x 115 x 144	5,51	100 x 125 x 151	7,26
75	100 x 120 x 160	6,62	120 x 150 x 178	12,94

SAS SYSTEMS

Ankerstück
anchor piece

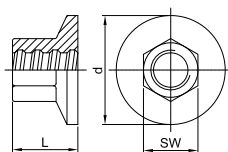

Ø [mm]	T 2073		TR 2073	
	SW x L x d [mm]	[kg]	SW x L x d [mm]	[kg]
25	41 x 45 x 70	0,50	41 x 50 x 75	0,60
26	41 x 50 x 90	0,70	---	---
28	46 x 50 x 90	0,77	46 x 55 x 85	0,79
30	50 x 55 x 95	1,00	50 x 60 x 90	1,00
32	50 x 60 x 100	1,40	---	---
35	---	---	60 x 70 x 105	1,54
36	60 x 65 x 110	1,75	---	---
40	65 x 70 x 120	1,85	---	---
43	70 x 80 x 130	2,43	70 x 85 x 130	2,51
50	80 x 85 x 150	3,75	80 x 100 x 150	4,38
57,5	90 x 100 x 175	6,09	90 x 115 x 175	6,67
63,5	100 x 115 x 190	7,38	100 x 125 x 190	8,66
75	---	---	120 x 150 x 230	14,73

SAS SYSTEMS

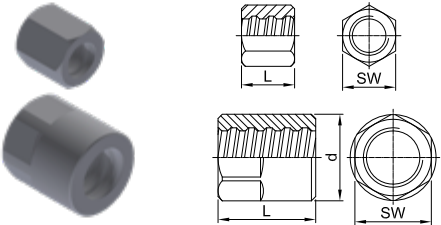
	Ø [mm]	SW x L [mm]	[kg]	SW x L [mm]	[kg]
		T 2003		TR 2003	
Kontermutter lang <i>lock nut long</i> 	25	41 x 40	0,25	41 x 50	0,37
	26	41 x 45	0,26	---	---
	28	41 x 45	0,26	46 x 55	0,50
	30	50 x 50	0,52	50 x 60	0,67
	32	50 x 50	0,47	---	---
	35	---	---	55 x 65	0,78
	36	55 x 55	0,61	---	---
	40	60 x 65	0,83	---	---
	43	70 x 65	1,31	70 x 80	1,60
	50	80 x 80	1,94	80 x 90	2,27
	57,5	90 x 80 x 102	2,87	90 x 100 x 102	3,56
	63,5	90 x 115 x 102	3,55	100 x 115 x 114	5,26
	75	100 X 80 x 108	2,37	100 x 120 x 108	3,67

SAS SYSTEMS

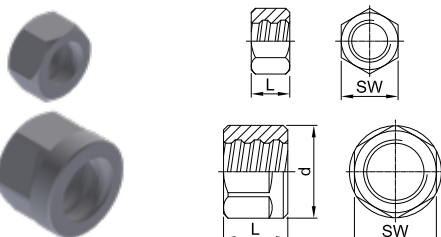
	Ø [mm]	SW x L [mm]	[kg]	SW x L [mm]	[kg]
		T 2040		TR 2040	
Kontermutter kurz <i>lock nut short</i> 	25	41 x 20	0,14	41 x 22	0,16
	26	41 x 25	0,15	---	---
	28	41 x 25	0,15	46 x 30	0,26
	30	50 x 30	0,28	50 x 30	0,31
	32	50 x 30	0,28	---	---
	35	---	---	55 x 40	0,47
	36	55 x 30	0,37	---	---
	40	60 x 35	0,45	---	---
	43	70 x 40	0,80	70 x 50	1,00
	50	80 x 50	1,21	80 x 50	1,26
	57,5	90 x 60 x 102	2,08	90 x 60 x 102	1,93
	63,5	90 x 75 x 102	2,18	100 x 70 x 114	2,98
	75	100 x 80 x 108	2,12	100 x 80 x 108	2,70



Zubehör

accessories

SAS SYSTEMS

Ankerplatte gerade
anchor plate flat

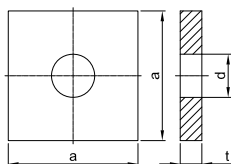

Ø [mm]	T 2139		TR 2139	
	a x t x d [mm]	[kg]	a x t x d [mm]	[kg]
25	90 x 15 x 30	0,87	115 x 30 x 30	2,95
26	100 x 15 x 33	1,08	---	---
28	100 x 15 x 33	1,08	120 x 30 x 34	3,18
30	120 x 20 x 36	2,10	130 x 35 x 36	4,36
32	120 x 20 x 40	2,06	---	---
35	---	---	150 x 40 x 42	6,63
36	150 x 30 x 44	4,94	---	---
40	150 x 30 x 47	4,89	---	---
43	160 x 40 x 50	7,42	185 x 55 x 50	13,93
50	190 x 45 x 58	11,82	215 x 60 x 60	20,44
57,5	220 x 50 x 67	17,61	245 x 65 x 67	28,83
63,5	245 x 50 x 70	22,05	270 x 70 x 74	37,70
75	275 x 65 x 88	35,48	325 x 70 x 86	54,85

SAS SYSTEMS

Ankerplatte Konus 55°
anchor plate cone 55°

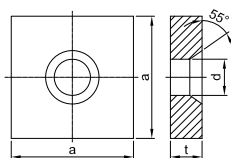

Ø [mm]	T 2011		TR 2011	
	a x t x d [mm]	[kg]	a x t x d [mm]	[kg]
25	90 x 15 x 35	0,81	125 x 30 x 35	3,40
26	---	---	---	---
28	100 x 20 x 40	1,33	135 x 35 x 40	4,59
30	---	---	145 x 35 x 40	5,32
32	120 x 20 x 52	1,91	---	---
35	---	---	170 x 40 x 47	8,36
36	---	---	---	---
40	150 x 30 x 65	4,48	---	---
43	160 x 40 x 75	6,54	210 x 50 x 58	15,96
50	190 x 45 x 83	10,78	240 x 55 x 70	22,59
57,5	220 x 50 x 92	16,25	275 x 60 x 75	32,77
63,5	245 x 50 x 104	20,09	300 x 65 x 82	42,19
75	275 x 65 x 118	32,60	325 x 70 x 100	51,89

SAS SYSTEMS

Ankerplatte Konus 55° mit Auflager
anchor plate cone 55° with support

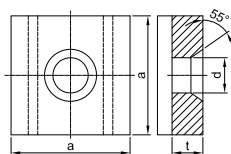

Ø [mm]	T 2011 ST		TR 2011 ST	
	a x t x d [mm]	[kg]	a x t x d [mm]	[kg]
25	90 x 15 x 35	---	125 x 30 x 35	---
26	---	---	---	---
28	100 x 20 x 40	---	135 x 35 x 40	---
30	---	---	145 x 35 x 40	---
32	120 x 20 x 52	---	---	---
35	---	---	170 x 40 x 47	---
36	---	---	---	---
40	150 x 30 x 65	---	---	---
43	160 x 40 x 75	---	210 x 50 x 58	---
50	190 x 45 x 83	---	240 x 55 x 70	---
57,5	220 x 50 x 92	---	275 x 60 x 75	---
63,5	245 x 50 x 104	---	300 x 65 x 82	---
75	275 x 65 x 118	---	325 x 70 x 100	---

SAS SYSTEMS

	Ø [mm]	L x d [mm]	[kg]	L x d [mm]	[kg]
		T 3003		TR 3003	
Muffe standard <i>coupler standard</i>	25	40 x 115	0,25	45 x 120	0,95
	26	45 x 120	0,26	---	---
	28	45 x 125	0,26	50 x 140	1,36
	30	50 x 135	0,52	55 x 150	1,84
	32	52 x 140	0,47	---	---
	35	---	---	65 x 170	2,95
	36	60 x 150	0,61	---	---
	40	65 x 160	0,83	---	---
	43	80 x 170	1,31	80 x 200	5,42
	50	80 x 200	1,94	90 x 210	6,92
	57,5	102 x 230	2,87	102 x 250	10,31
	63,5	102 x 260	3,55	114 x 300	15,89
	75	108 x 240	2,37	108 x 260	8,98

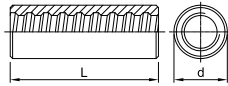

SAS SYSTEMS

	Ø [mm]	L x d [mm]	[kg]	L x d [mm]	[kg]
		T 3020		TR 3020	
Muffe mit Drehsicherung <i>coupler with set screws</i>	25	---	---	45 x 120	0,95
	26	---	---	---	---
	28	---	---	50 x 140	1,36
	30	---	---	55 x 150	1,84
	32	52 x 140	1,35	---	---
	35	---	---	65 x 170	2,95
	36	60 x 150	2,00	---	---
	40	65 x 160	2,35	---	---
	43	80 x 170	4,41	80 x 200	5,42
	50	80 x 200	4,50	90 x 210	6,92
	57,5	102 x 230	9,45	102 x 250	10,31
	63,5	102 x 260	9,50	114 x 300	15,89
	75	108 x 240	8,02	108 x 260	8,98

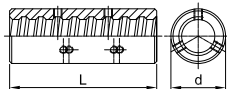

SAS SYSTEMS

	Ø [mm]	L x d x d _A [mm]	[kg]	L x d x d _A [mm]	[kg]
		T 3087		TR 3087	
Gewindemuffe <i>thread coupler</i>	25	40 x 46 x 115	0,68	47 x 53 x 120	1,18
	26	47 x 53 x 120	1,13	---	---
	28	47 x 53 x 125	1,09	47 x 53 x 140	1,23
	30	47 x 53 x 135	1,10	57 x 64 x 150	2,19
	32	57x64x140	1,92	---	---
	35	---	---	65 x 72 x 170	3,11
	36	57x64x150	1,78	---	---
	40	65 x 72 x 160	2,52	---	---
	43	75 x 82 x 170	3,79	75 x 82 x 200	4,77
	50	---	---	---	---
	57,5	---	---	---	---
	63,5	---	---	---	---
	75	---	---	---	---

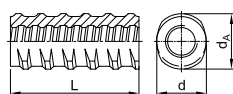

Zubehör

accessories

SAS SYSTEMS

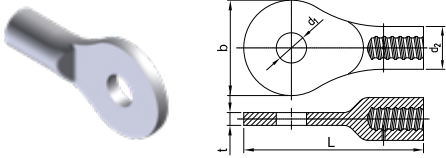
	∅ [mm]	L x b x t x d ₁ x d ₂ [mm]	[kg]	L x b x t x d ₁ x d ₂ [mm]	[kg]
		T 2080		TR 2080	
Augenstück <i>eye piece</i> 	25	auf Anfrage on request		---	---
	26			---	---
	28			---	---
	30			---	---
	32			---	---
	35			167 x 315 x 22,5 x 53 x 75	7,40
	36			---	---
	40			---	---
	43			197 x 364 x 25 x 63 x 92	12,80
	50			221 x 406 x 31 x 75 x 94	18,00
	57,5			248 x 453,5 x 38 x 88 x 96	20,40
	63,5			298 x 553 x 38 x 98 x 114	34,50
	75			328 x 587 x 50 x 108 x 116	44,40

SAS SYSTEMS

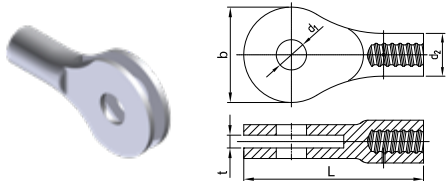
	∅ [mm]	t x b x L x d ₁ x d ₂ [mm]	[kg]	t x b x L x d ₁ x d ₂ [mm]	[kg]
		T 2090		TR 2090 EP	
Gabelstück <i>fork piece</i> 	25	auf Anfrage on request		---	---
	26			---	---
	28			---	---
	30			---	---
	32			---	---
	35			27 x 167 x 315 x 56 x 75	7,40
	36			---	---
	40			---	---
	43			29 x 197 x 384 x 63 x 92	12,80
	50			35 x 221 x 406 x 75 x 94	18,00
	57,5			42 x 248 x 453,5 x 88 x 96	20,40
	63,5			42 x 298 x 553 x 98 x 114	34,50
	75			54 x 328 x 627 x 108 x 116	44,40

SAS SYSTEMS

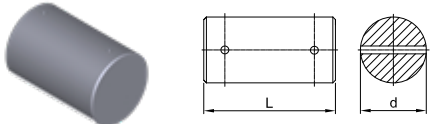
	∅ [mm]	L x d [mm]	[kg]	L x d [mm]	[kg]
		T 2081		TR 2081	
Bolzen Augenstück <i>bolt eye piece</i> 	25	auf Anfrage on request		---	----
	26			---	---
	28			---	---
	30			---	---
	32			---	---
	35			50 x 100	1,52
	36			---	---
	40			---	---
	43			60 x 110	2,40
	50			72 x 105	3,31
	57,5			85 x 145	6,45
	63,5			95 x 145	9,02
	75			105 x 165	11,21

SAS SYSTEMS

∅ [mm]

a x b x t x d x L_a x L_b x L_c [mm]

[kg]

T 3081

TR 3081

Anschweißlasche Augenstück
welding plate eye piece

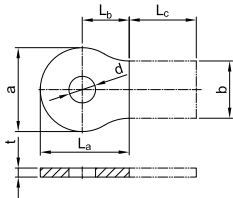

25
26
28
30
32
35
36
40
43
50
57,5
63,5
75

auf Anfrage
on request

---	---
---	---
---	---
---	---
---	---
---	---
167 x 114 x 18 x 53 x 177 x 93,5 x L _c	7,40
---	---
---	---
197 x 134 x 20 x 63 x 207 x 108,5 x L _c	12,80
221 x 150 x 25 x 75 x 228 x 117,5 x L _c	18,00
248 x 160 x 30 x 88 x 263 x 139 x L _c	20,40
298 x 200 x 30 x 98 x 313 x 164 x L _c	34,50
328 x 220 x 35 x 108 x 345,5 x 181,5 x L _c	44,40

SAS SYSTEMS

∅ [mm]

a x t x b x d x L x L₁ [mm]

[kg]

T 3080

TR 3080

Verbindungslasche Augenstück
strap connection eye piece

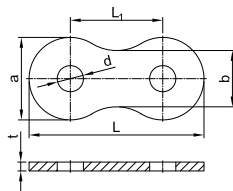

25
26
28
30
32
35
36
40
43
50
57,5
63,5
75

auf Anfrage
on request

---	---
---	---
---	---
---	---
---	---
167 x 18 x 114 x 53 x 354 x 187	7,00
---	---
---	---
197 x 20 x 134 x 63 x 414 x 217	9,60
221 x 25 x 150 x 75 x 456 x 235	14,37
248 x 30 x 160 x 88 x 526 x 278	22,00
298 x 30 x 200 x 98 x 626 x 328	31,80
328 x 35 x 220 x 108 x 691 x 363	45,80

SAS SYSTEMS

∅ [mm]

a x L x a [mm]

[kg]

T 2082

TR 2082

Kardangelenk
cardan joint

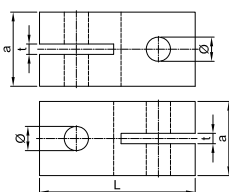

25
26
28
30
32
35
36
40
43
50
57,5
63,5
75

auf Anfrage
on request

---	---
---	---
---	---
---	---
---	---
110 x 340 x 110	21,96
---	---
---	---
125 x 380 x 125	31,67
150 x 440 x 150	52,84
170 x 490 x 170	73,16
185 x 560 x 185	101,80
200 x 620 x 200	140,57

Zubehör

accessories

SAS SYSTEMS

∅ [mm]

d x L [mm]

[kg]

T 2020

TR 2020

Gelenkmutter
joint nut

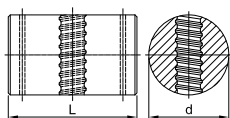

25
26
28
30
32
35
36
40
43
50
57,5
63,5
75

auf Anfrage
on request

---	---
---	---
---	---
---	---
---	---
120 x 193	16,00
---	---
---	---
140x212	23,80
---	---
150 x 222	27,00
190 x 265	53,40
190 x 279	55,00

SAS SYSTEMS

∅ [mm]

d x L [mm]

[kg]

T 2021

TR 2021

Gelenkbolzen
joint bolt

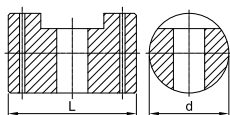

25
26
28
30
32
35
36
40
43
50
57,5
63,5
75

auf Anfrage
on request

---	---
---	---
---	---
---	---
---	---
120 x 193	14,60
---	---
---	---
140x212	21,20
---	---
150 x 222	24,60
190 x 265	50,20
190 x 279	52,00

SAS SYSTEMS

∅ [mm]

L x SW [mm]

[kg]

L x SW [mm]

[kg]

T 3105

TR 3105

Spannschloss
turnbuckle

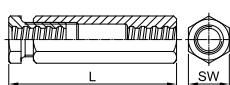

25
26
28
30
32
35
36
40
43
50
57,5
63,5
75

46 x 190	1,42
50 x 205	1,83
50 x 205	1,78
60 x 225	2,92
60 x 225	2,87
---	---
70 x 250	5,20
80 x 270	6,60
90 x 290	12,21
100 x 310	16,87
100 x 340	18,44
100 x 395	24,37
110 x 370	19,57

55 x 205	2,67
---	---
60 x 225	3,31
65 x 260	4,45
---	---
80 x 275	7,50
---	---
---	---
90 x 330	13,70
100 x 350	16,97
100 x 405	21,25
100 x 425	19,02
110x460	21,28

Standardanschlüsse an Spundwände

standard connections to sheet pile walls

Verbindung mit der Spundwand

Die Lasten werden über die Spundwand auf die Zugstäbe durch die vor der Wand angeordnete Gurtung übertragen. Um Biegungen im Anschlussbereich des Zugstabes zur Gurtung zu minimieren, werden gelenkige Verbindungen empfohlen.

Für verschiedene Gurtspreizungen g_s sind in unten stehender Tabelle Plattendimensionen angegeben. Die Werte für die Plattenbreite h sind Mindestwerte $\min h$. Die Auflagerlänge der Platten auf den U-Profilen beträgt ≥ 30 mm. Für Auflagerlängen ≥ 30 mm sind die Platten gesondert statisch nachzuweisen. Die dargestellten Plattendimensionen gelten für geradeliegende Anker. Gurtspreizungen g_s

Connections to sheet piles

Forces are transferred from the sheet pile wall to the tie rod through walers which are installed at the wall. To minimize bending at the connection from the tie rod to the waler, articulation connections are recommended.

For different waling bracings g_s the below-mentioned table shows dimensions for the plates. The dimensions of the plate width h are minimum values $\min h$. The bearing length of the plates on the U-profiles is ≥ 30 mm. For bearing length ≤ 30 mm a statical verification has to be done separately. The dimensions of the plates are valid for straight-lined anchors. waling bracings g_s

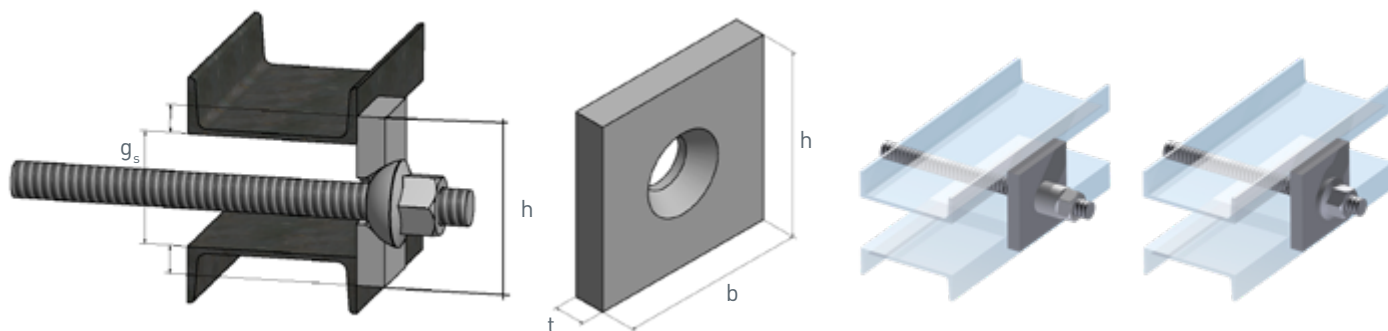

Ankerplatte Konus 55° / anchor plate cone 55°

g_s	[mm]	80						100						120						140					
		\emptyset	h	b	t	d_L	d_k	[kg]	h	b	t	d_L	d_k	[kg]	h	b	t	d_L	d_k	[kg]	h	b	t	d_L	d_k
	[mm]	[mm]						[mm]						[mm]						[mm]					
T 2011 ST	40	140	150	30	65	76	4,13	160	150	35	65	76	5,64	180	180	35	65	76	7,95	-	-	-	-	-	-
	43	140	160	35	75	93	4,82	160	160	40	75	93	6,53	180	190	40	75	93	9,23	-	-	-	-	-	-
	50	-	-	-	-	-	-	160	180	45	83	96	8,20	180	200	50	83	96	11,94	-	-	-	-	-	-
	57,5	-	-	-	-	-	-	160	190	55	92	110	10,11	180	200	60	92	110	13,68	200	200	60	92	110	15,56
	63,5	-	-	-	-	-	-	-	-	-	-	-	-	180	220	65	104	121	15,73	200	200	60	104	121	14,70
	75	-	-	-	-	-	-	-	-	-	-	-	-	-	-	-	-	-	-	-	200	200	70	118	145
TR 2011 ST	35	140	150	30	47	73	4,36	160	150	35	47	73	5,94	180	180	35	47	73	8,25	-	-	-	-	-	-
	43	140	180	40	58	90	6,75	160	180	45	58	90	8,91	180	180	45	58	90	10,18	-	-	-	-	-	-
	50	140	190	50	70	110	8,30	160	190	55	70	110	10,83	180	200	55	70	110	13,25	-	-	-	-	-	-
	57,5	140	200	55	75	119	9,35	160	190	65	75	119	12,43	180	200	65	75	119	15,29	200	200	65	75	119	17,33
	63,5	-	-	-	-	-	-	160	200	70	82	131	13,56	180	200	70	82	131	15,75	200	200	75	82	131	19,32
	75	-	-	-	-	-	-	-	-	-	-	-	-	180	230	85	100	159	20,40	200	240	80	100	159	23,23

Standardanschlüsse an Spundwände

standard connections to sheet pile walls

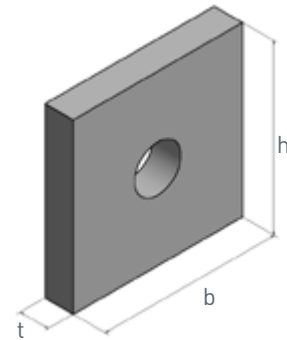
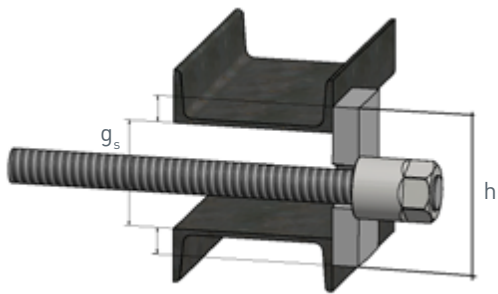

Ankerplatte gerade / anchor flat

	g _s	80					100					120					140						
		∅	h	b	t	d _L	[kg]	h	b	t	d _L	[kg]	h	b	t	d _L	[kg]	h	b	t	d _L	[kg]	
		[mm]					[mm]					[mm]					[mm]						
SAS 500	40	140	150	35	47	5,30	160	170	40	47	8,00	180	200	40	47	10,76							
	43	140	150	40	50	5,98	160	170	40	50	7,93	180	200	45	50	12,03							
	50	140	160	45	58	6,98	160	180	45	58	9,25	180	200	50	58	13,10							
	57,5	140	190	55	67	9,97	160	200	55	67	12,30	180	200	60	67	15,30	200	220	65	67	20,66		
	63,5	140	200	60	70	11,38	160	200	65	70	14,37	180	220	65	70	18,25	200	220	70	70	22,07		
	75						180	200	70	88	16,44	180	240	70	88	20,40	200	220	75	88	22,33		
SAS 650	35	140	140	40	42	5,72	160	170	40	42	8,11	180	180	45	42	10,96							
	43	140	160	45	50	7,22	160	170	50	50	9,91	180	200	50	50	13,36							
	50	140	180	50	60	8,79	160	180	55	60	11,22	180	210	55	60	15,10							
	57,5	140	200	60	67	11,53	160	200	60	67	13,42	180	220	65	67	18,41	200	220	70	67	22,25		
	63,5	140	200	70	74	13,03	160	200	70	74	15,23	180	220	70	74	19,40	200	240	75	74	25,73		
	75						160	240	80	86	20,47	180	220	85	86	22,25	200	260	85	86	30,83		



Standardanschlüsse an Spundwände

standard connections to sheet pile walls

Kombinierte Spundwand mit
Rohrpfählen

combined sheet pile wall with piles



HZ-M-wall

Double HZ-M-wall

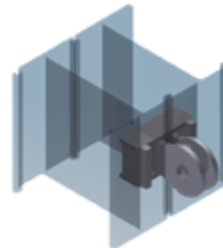

Gelenkmutter
joint nut

Gelenkbolzen
joint bolt

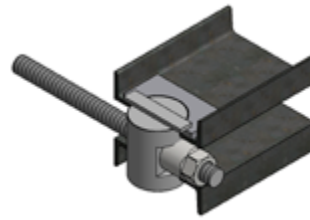
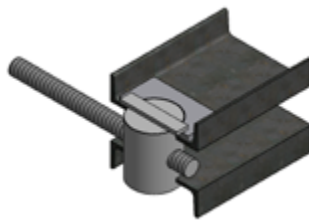

Muffenverbindung
coupler connection

Augenstückverbindung
eye-piece connection

Kardan Verbindung
kardan connection



Winkelausgleich nicht möglich
no angle adjustment possible

Winkelausgleich in x-Richtung
angle adjustment to x-direction

Winkelausgleich in x-y-Richtung
angle adjustment to x-y-direction

Gurtungen

walings

Grundlage für die Anordnung, Ausbildung und Befestigung der Gurte bildet die EAU 2004. In der baupraktischen Anwendung wird unterschieden in Zug- und Druckgurte. Je nach Anwendung werden diese auf der Innenseite der Wand bzw. hinter der Wand angebracht. Die in Abhängigkeit der Gurtspreizung einzusetzenden Ankerplatten sind auf Seiten 15-16 dieses Handbuches aufgeführt. Nachfolgendes Kapitel beschreibt Gurtkonsolen, Gurtstoßausbildungen sowie Gurtbolzen und gibt einen kurzen Überblick über Anwendungsbeispiele.

The EAU 2004 is the basis of the arrangement, design and fixing of steel walings. The application of walings can be differentiated into tension and compression walings. Behind the wall they are installed as compression walings resp. on the inboard side they are installed as tension walings. On pages 15-16 of this manual the client will find information about the anchor plates in according to the waling bracing. This chapter describes waling consoles, waling construction and waling bolts and finally presents an overview of the application of walings.

Gurtkonsolen

waling consoles

Gurtkonsolen leiten Erdauflasten, Vertikallasten und Eigengewicht über Schweißnähte in die Spundwand ein.

Waling consoles transmit vertical, dead and earth load by welding seams to the sheet pile.

Profile für Gurtkonsolen / Profiles of waling consoles

Gurtprofil waling profile		I[180	I[200	I[220	I[240	I[260	I[280	I[300	I[320	I[350	I[380	I[400
h	mm	230	250	270	290	310	330	350	370	400	430	450
b	mm	230	250	270	290	310	330	350	370	400	430	450
	kg	2,89	3,34	3,83	4,35	4,90	5,48	6,09	6,73	7,76	8,85	9,62

Werkstoff / material: S235 / S355

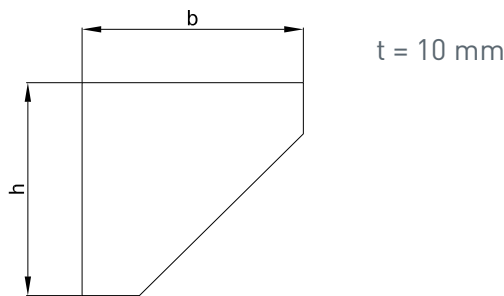

II	Gurtung waling		Stoßlasche II butt strap			Abmessungen dimension						Schrauben DIN 933 screws			Mutter nut	Scheibe washer	Ge- wicht weight	
	Wy kg/m	cm3	II	l mm	kg	a mm	b mm	c mm	eØ mm	f mm	g mm	h mm	Anzahl quantity	Grö- ße size	Länge length	DIN 934	DIN 125	kg
UNP180	300	44,0	UNP120	560	14,9	37,5	45	67,5	22	40	60	80	32	M20	45	Ø37/Ø21x3	M20	8,0
UNP200	382	50,6	UNP140	640	20,5	40,0	60	70,0	22	40	60	120	32	M20	45	mm	M20	8,0
UNP220	490	58,8	UNP160	680	25,7	40,0	80	70,0	22	40	60	140	32	M20	45	mm	M20	8,0
UNP240	600	66,4	UNP180	740	32,6	45,0	90	75,0	26	50	75	120	32	M24	50	Ø44/Ø25x4	M24	13,0
UNP260	742	75,8	UNP200	800	40,5	45,0	110	75,0	26	50	75	150	32	M24	50	mm	M24	13,0
UNP280	892	83,8	UNP220	840	49,4	50,0	120	80,0	26	50	90	140	40	M24	55	mm	M24	16,0
UNP300	1070	92,4	UNP220	920	54,1	50,0	120	90,0	26	50	90	180	40	M24	55	mm	M24	16,0
UNP320	1360	119,0	UNP240	1000	66,4	55,0	130	95,0	32	60	110	160	40	M30	65	mm	M30	35,0
UNP350	1468	121,2	UNP260	1000	75,8	60,0	140	105,0	32	60	110	160	40	M30	65	Ø56/Ø31x4	M30	35,0
UNP380	1660	126,2	UNP300	1000	92,2	60,0	180	100,0	32	60	90	200	48	M30	65	mm	M30	42,0
UNP400	2040	143,6	UNP300	1000	92,2	60,0	180	110,0	32	60	90	200	48	M30	65	mm	M30	42,0
UPE180	301	39,5	UPE120	560	13,6	37,5	45	67,5	22	40	60	80	32	M20	45	Ø37/Ø21x3	M20	8,0
UPE200	382	45,6	UPE140	640	18,6	40,0	60	70,0	22	40	60	120	32	M20	45	mm	M20	8,0
UPE220	488	53,2	UPE160	680	23,2	40,0	80	70,0	22	40	60	140	32	M20	45	mm	M20	8,0
UPE240	600	60,5	UPE180	740	29,2	45,0	90	75,0	26	50	75	120	32	M24	50	Ø44/Ø25x4	M24	13,0
UPE270	780	70,4	UPE200	840	38,3	45,0	110	80,0	26	50	90	140	40	M24	55	mm	M24	16,0
UPE300	1043	88,9	UPE220	920	49,0	50,0	120	90,0	26	50	90	180	40	M24	55	mm	M24	16,0
UPE330	1335	106,4	UPE240	1000	60,5	55,0	130	100,0	32	60	110	160	40	M30	65	mm	M30	35,0
UPE360	1648	122,4	UPE270	1000	70,4	65,0	140	110,0	32	60	110	160	40	M30	65	mm	M30	35,0
UPE400	2098	144,4	UPE300	1000	88,9	60,0	180	110,0	32	60	90	200	48	M30	65	mm	M30	42,0

Werkstoff / material: S235 / S355

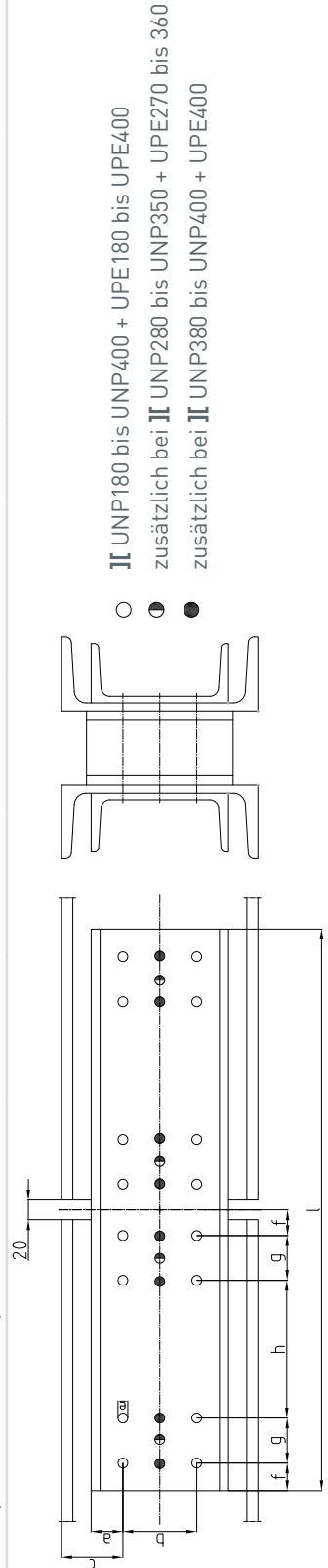

Gurtbolzen

waling bolts

Gurtbolzen mit Kopf und Mutter

Waling bolts with head and nut

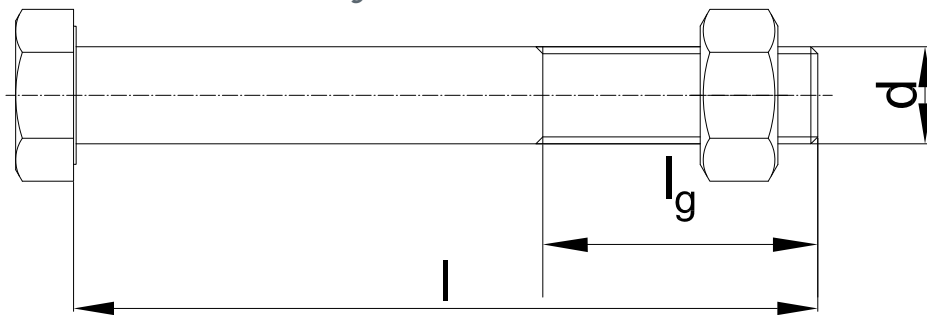

Abmaße Gurtbolzen / Dimensions waling bolts

Nenn / nom d	Zoll	1	1 1/4	1 1/2	1 3/4	2	2 1/4	2 1/2	2 3/4	3	3 1/4	3 1/2
I[200	l [mm]	320	320	340	360							
	l _g [mm]	85	95	105	115							
	kg	1,59	2,55	4,08	5,90							
I[220	l [mm]	340	340	360	380	400						
	l _g [mm]	85	95	105	115	125						
	kg	1,67	2,67	4,26	6,15	8,36						
I[240	l [mm]	360	360	380	400	420	440	460				
	l _g [mm]	85	95	105	115	125	130	135	140			
	kg	1,75	2,79	4,44	6,39	8,66	11,75	14,58	18,69			
I[260	l [mm]	380	380	400	420	440	440	460	480	500	510	530
	l _g [mm]	85	95	105	115	125	130	135	140	145	150	155
	kg	1,83	2,91	4,62	6,63	8,98	12,15	15,07	19,29	23,15	29,27	35,65
I[280	l [mm]	400	400	420	440	460	460	480	500	520	530	550
	l _g [mm]	85	95	105	115	125	130	135	140	145	150	155
	kg	1,91	3,03	4,80	6,86	9,28	12,55	15,56	19,90	23,84	30,12	36,64
I[300	l [mm]		420	440	460	480	480	500	520	540	550	570
	l _g [mm]		95	105	115	125	130	135	140	145	150	155
	kg		3,15	4,98	7,10	9,59	12,95	16,05	20,50	24,54	30,97	37,64
I[320	l [mm]		440	460	480	500	500	520	540	560	570	590
	l _g [mm]		95	105	115	125	130	135	140	145	150	155
	kg		3,20	5,09	7,40	9,90	13,15	16,54	21,11	25,23	31,82	38,64
I[350	l [mm]			490	510	530	530	550	570	590	600	620
	l _g [mm]			105	115	125	130	135	140	145	150	155
	kg			5,37	7,61	10,36	13,77	17,27	22,01	26,27	33,10	40,14
I[380	l [mm]			520	540	560	560	580	600	620	630	650
	l _g [mm]			105	115	125	130	135	140	145	150	155
	kg			5,63	8,15	10,82	14,39	18,01	22,92	27,31	34,37	41,63
I[400	l [mm]			540	560	580	580	600	620	640	650	670
	l _g [mm]			105	115	125	130	135	140	145	150	155
	kg			5,92	8,37	11,13	15,07	18,50	23,52	28,01	35,22	42,63

Material / material: S235JR / S355J2+N

Im Gewicht ist die Mutter mit enthalten. / The weight of the nut is included.

Gurtbolzen mit zwei Muttern
Waling bolts with two nuts

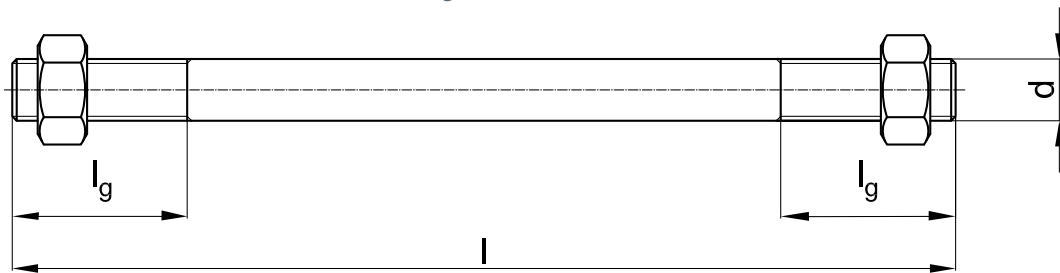

Abmaße Gurtbolzen / Dimensions waling bolts

Nenn / nom d	Zoll	1	1 1/4	1 1/2	1 3/4	2	2 1/4	2 1/2	2 3/4	3	3 1/4	3 1/2
I[200	l [mm]	350	380	400	440							
	l _g [mm]	85	95	105	115							
	kg	1,59	2,74	4,25	6,90							
I[220	l [mm]	380	410	430	460	480						
	l _g [mm]	85	95	105	115	125						
	kg	1,71	2,93	4,52	7,15	9,31						
I[240	l [mm]	390	420	440	470	510	510	530	560	580	600	630
	l _g [mm]	85	95	105	115	125	130	135	140	145	150	155
	kg	1,75	2,99	4,61	7,27	9,78	13,35	16,78	21,71	25,92	33,10	40,63
I[260	l [mm]	410	440	460	490	530	530	550	580	600	620	630
	l _g [mm]	85	95	105	115	125	130	135	140	145	150	155
	kg	1,83	3,12	4,79	7,52	10,10	13,77	17,27	22,31	26,62	33,95	41,63
I[280	l [mm]	430	460	480	510	550	550	570	600	620	640	670
	l _g [mm]	85	95	105	115	125	130	135	140	145	150	155
	kg	1,91	3,24	4,97	7,75	10,42	14,18	17,76	22,92	27,31	24,80	42,63
I[300	l [mm]		480	510	540	570	570	600	620	640	660	690
	l _g [mm]		95	105	115	125	130	135	140	145	150	155
	kg		3,35	5,24	8,15	10,74	14,59	18,50	23,52	28,01	36,65	43,63
I[320	l [mm]			530	560	590	590	620	640	660	680	710
	l _g [mm]			105	115	125	130	135	140	145	150	155
	kg			5,41	8,40	11,18	15,01	18,99	24,13	28,70	36,30	44,63
I[350	l [mm]			550	580	620	620	640	660	680	710	740
	l _g [mm]			105	115	125	130	135	140	145	150	155
	kg			5,56	8,85	11,46	15,83	19,48	24,73	29,39	37,77	46,12
I[380	l [mm]			580	650	650	670	680	710	740	740	770
	l _g [mm]			105	115	125	130	135	140	145	150	155
	kg			5,86	9,02	12,11	16,25	20,21	25,33	30,09	39,05	47,62
I[400	l [mm]			600	630	670	670	690	700	730	760	790
	l _g [mm]			105	115	125	130	135	140	145	150	155
	kg			6,06	9,27	12,34	16,67	20,70	25,94	30,78	37,90	48,62

Material / material: S235JR / S355J2+N

Im Gewicht ist die Mutter mit enthalten. / The weight of the nut is included.

Beispiele für Gurtungen

examples for walings

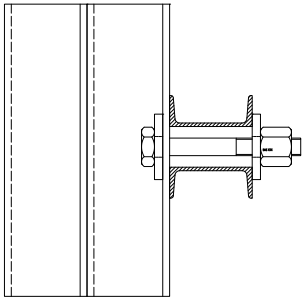

Regelausführung der Gurtbefestigung
Conventional fixing of the waling

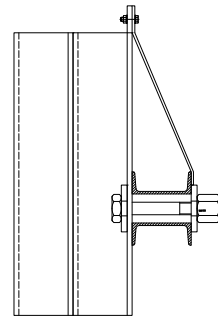

Aufhängung des Gurtes
Waling suspension

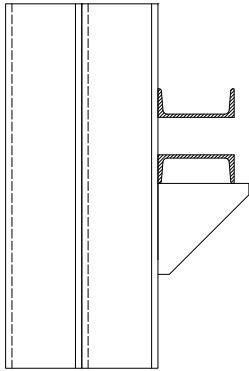

Gurtkonsole
Waling console

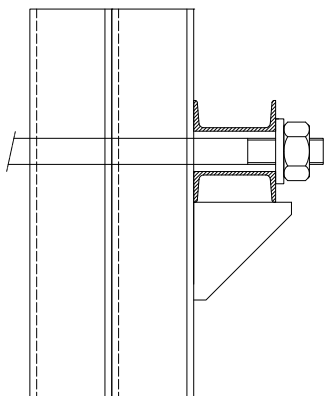
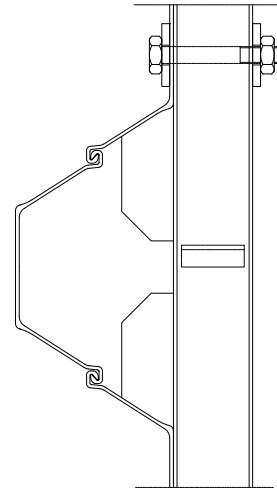

Üblicher Anschluss an der Ankerwand
Conventional connection anchor wall

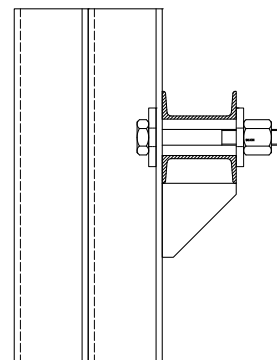

Knaggen zur Übertragung von Längskräften
appets for the longitudinal forces

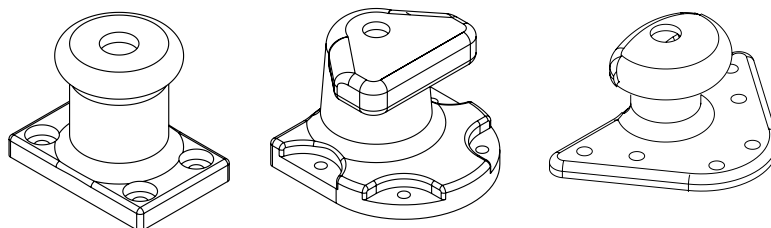

Plattformpoller 50 - 100 kN, 50 - 2500 kN, Kantenpoller 50 - 300 kN
 Platform bollard, 50 - 100 kN, 50 - 2500 kN, edge bollard 50 - 300 kN

Abmaße für Kantenpoller

Dimensions of edge bollards

Trossenzug cable pull	A	B	C	D	E	G	J	Gewicht weight	Werkstoff material	
kN									kg	
50	140	710	415	300	260	40	340	93	EN-GJL-250	
100	140	710	415	300	260	40	340	93		
150	140	710	415	300	260	40	340	93		
200	140	710	415	300	260	40	340	93		
300	140	710	415	300	250	55	340	122	EN-GJS-400-154	

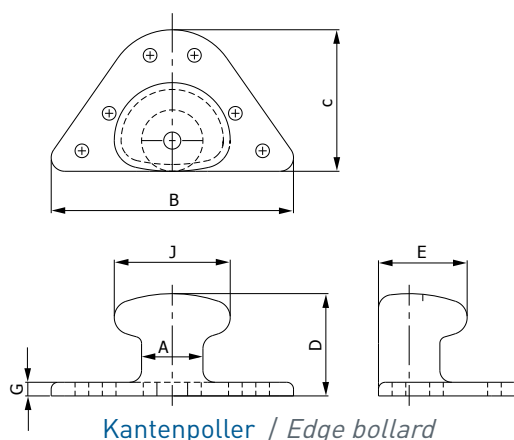

Normal- und Abreißverankerungen für Kantenpoller

Conventional and separation anchorages of edge bollards

Trossenzug cable pull	Anzahl quantity	D	a Ø mm	Ankerschrauben anchor screws				Abreißbolzen break stud bolt		Muffe coupler		Scheibe washer	Mutter nut
				l_N mm	l_{gN} mm	l_A mm	l_{gA} mm	b mm	c mm	g Ø mm	h mm	DIN 126	
50	4	M24	55	550	50	440	35	100	45	38	80	26	M24
100	4	M27	68	600	50	485	40	105	50	40	90	30	M27
150	6	1 1/4"	83	650	60	530	45	110	55	50	100	36	1 1/4"
200	6	1 1/2"	98	700	70	565	50	115	60	60	120	42	1 1/2"
300	6	1 1/2"	98	700	75	565	60	115	60	60	120	42	1 1/2"

Skizzen siehe Seite 25.

sketches on page 25.

Haltepoller

mooring bollards

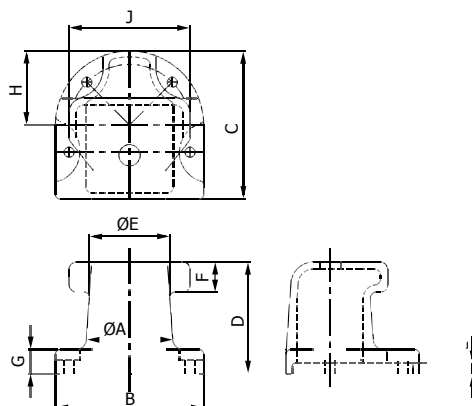

Haltepoller / Mooring bollard 50 - 700 kN

Abmaße Haltepoller

Dimensions Mooring bollard

Trossenzug cable pull	Ø A	B	C	D	Ø E	F	G	H	J	L	Gewicht weight	Werkstoff material
kN											kg	
50	230	400	400	310	190	80	60	200	320	30	62	EN-GJL-250
100	290	490	490	370	250	100	80	245	400	45	127	
150	330	590	590	410	280	110	90	295	500	50	211	
200	240	600	600	450	290	120	95	300	500	55	228	
300	380	640	640	500	325	125	115	320	550	60	355	
500	415	700	700	520	355	140	120	350	580	65	440	
600	450	820	900	560	380	130	120	490	650	70	615	

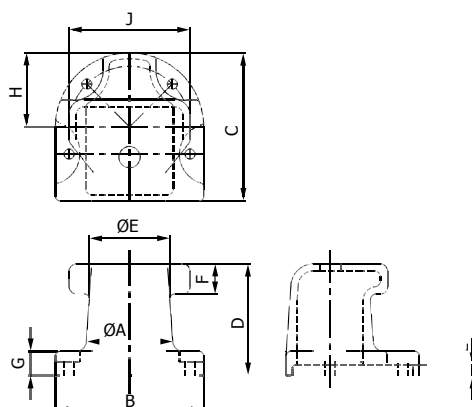

Haltepoller / Mooring bollard 800 - 2500 kN

Abmaße Haltepoller

Dimensions Mooring bollard

Trossenzug cable pull	Ø A	B	C	D	Ø E	F	G	H	J	L	Gewicht weight	Werkstoff material
kN											kg	
700	450	820	900	650	380	130	120	490	650	70	615	EN-GJL-250
800	480	730	900	650	420	165	150	450	730	90	900	
1000	480	900	900	800	420	165	150	450	730	90	900	
1250	545	1050	1050	850	465	250	160	525	850	90	1220	
1500	590	1100	1100	850	520	269	180	550	870	100	1800	
2000	640	1200	1200	900	580	290	220	600	950	120	2000	
2500	730	1250	1250	950	660	300	230	625	1030	130	1800	ENGJS-45

Verankerung für Poller

anchorages for bollards

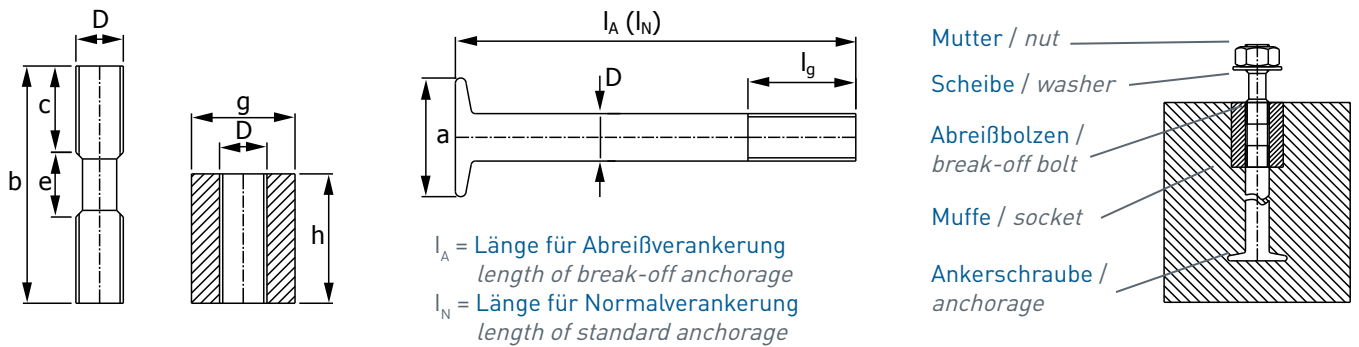

Abreißverankerungen, Normalverankerungen / break-off anchorage, standard anchorage

Normal- und Abreißverankerungen für Haltepoller

Conventional and separation anchorages of mooring bollards

Trossenzug cable pull	Anzahl quantity	D	a Ø mm	Ankerschrauben standard anchorage				Abreißbolzen break-off bolt		Muffe socket		Scheibe washer	Mutter nut
				l_N mm	l_{gN} mm	l_A mm	l_{gA} mm	b mm	c mm	g Ø mm	h mm	DIN 126	
50	4	M24	55	550	50	435	35	95	40	38	80	26	M24
100	4	M27	68	580	50	440	40	120	50	40	90	30	M27
150	4	1 1/4"	83	650	60	495	45	135	60	50	100	36	1 1/4"
200	4	1 1/2"	98	700	70	520	50	160	75	60	120	42	1 1/2"
300	4	2"	120	820	75	605	60	195	95	80	150	56	2"
500	4	2 1/4"	145	930	85	690	70	220	105	90	170	62	2 1/4"
600	4	2 1/2"	160	1040	90	760	90	240	115	100	210	66	2 1/2"
700	4	2 3/4"	180	1100	100	805	90	255	125	105	220	78	2 3/4"
800	6	2 1/2"	160	1120	90	820	90	260	120	100	210	66	2 1/2"
1000	6	2 3/4"	180	1120	100	805	90	275	130	105	220	78	2 3/4"
1250	6	3"	190	1220	100	890	100	290	140	115	240	78	3"
1500	6	3 1/4"	205	1340	110	980	110	320	155	125	260	86	3 1/4"
2000	7	3 1/2"	225	1460	115	1065	110	355	170	140	270	96	3 1/2"
2500	7	3 3/4"	238	1680	120	1255	120	385	180	150	290	107	3 3/4"

Korrosionsschutzsysteme

Corrosion protection systems

SAS Gewindestäbe und Zubehör können durch verschiedene Beschichtungssysteme gegen Korrosion geschützt werden. Je nach Anwendung variiert die Anforderung an das Beschichtungssystem. Die gängigsten Beschichtungssysteme für SAS Gewindestäbe und Zubehör sind nachfolgend beschrieben.

To protect SAS thread bars and accessories against corrosion different kinds of coating systems are available. The types of coating system can vary in accordance to the application. Some of the coating systems for SAS thread bars and accessories are described in the following chapter.

Lebensdauer / Lifetime	Korrosionsschutzsysteme / Corrosion protection systems		Bodenaggressivität / Soil Aggressiveness in accordance with 1)		
			niedrig / low	mittel / medium	Hoch / high
Temporär / temporary < 2 Jahre / years	Abrostraten nicht geschützter Stäbe	Sacrificial corrosion of unprotected bars	✓	✓	✓
	Denso Flex - Bandumwicklung	Denso Flex - wrapping	---	---	---
	Feuerverzinkung	Hot-dip galvanizing	---	✓	✓
	Schrumpfschlauch	Heat shrink sleeves	---	---	---
	Doppelter Korrosionsschutz (DCP)	Double corrosion protection (DCP)	---	---	---
Semi-permanent / semi-permanent 2 - 7 Jahre / years	Abrostraten nicht geschützter Stäbe	Sacrificial corrosion of unprotected bars	✓	✓	✓
	Denso Flex - Bandumwicklung	Denso Flex - wrapping	---	---	---
	Feuerverzinkung	Hot-dip galvanizing	✓	✓	✓
	Schrumpfschlauch	Heat shrink sleeves	---	---	---
	Doppelter Korrosionsschutz (DCP)	Double corrosion protection (DCP)	✓	✓	✓
Permanent	Abrostraten nicht geschützter Stäbe	Sacrificial corrosion of unprotected bars	✓	✓	---
> 7 Jahre / years	Denso Flex - Bandumwicklung	Denso Flex - wrapping	✓	---	---
	Feuerverzinkung	Hot-dip galvanizing	✓	✓	---
	Schrumpfschlauch	Heat shrink sleeves	---	✓	✓
	Doppelter Korrosionsschutz (DCP)	Double corrosion protection (DCP)	✓	✓	✓

¹⁾ in Anlehnung an die DIN EN 12501 / in accordance with DIN EN 12501



Abrostraten nicht geschützter Stäbe

Sacrificial corrosion of unprotected thread bars



Stahlbauteile können überdimensioniert eingebaut werden, um den Querschnittsverlust bei m „Abrosten“ zu kompensieren. Abhängig vom Baugrund können entspr. (DIN EN 1993-5:2010 Tab. 4-2) folgende Werte angesetzt werden:

Steel elements may be oversized to allow for loss of cross sectional area due to corrosion. Depending on the ground conditions, (DIN EN 1993-5:2010 Tab. 4-2) is suggesting the following loss of thickness of thread bars in the ground may be considered:

Geforderte planmäßige Nutzungsdauer [Jahre] Required scheduled useful life [years]		25	50
		Dickenverlust / loss of steel thickness [mm]	
Allgemeines Süßwasser (Fluss, Schiffskanal,) im Bereich hohen Angriffes (Wasserspiegel)	General freshwater (rivers, ship channel,) in the field of high attack (water level)	0,55	0,90
Sehr verunreinigtes Süßwasser (Abwasser, Industrieabwasser,) in der Zone hohen Angriffes (Wasser-spiegel)	Very polluted fresh water (sewage, industrial waste water,) in the zone of high attack (water level)	1,30	2,30
Seewasser in gemäßigttem Klima im Bereich hohen Angriffes (Niedrig-wasser und Spritzzone)	Seawater in a temperate climate in the area of high attack (low water and splash zone)	1,90	3,75
Seewasser in gemäßigttem Klima im Bereich, der ständig unter Wasser ist, oder in der Wasserwechselzone	Seawater in a temperate climate in the area, which is constantly under water, or in the wet and dry cycles	0,90	1,75
Die o.g. Werte gelten nur als Hinweis und müssen entspr. den örtlichen Gegebenheiten angepasst werden.		<i>The values above are for guidance only. Local conditions should be considered and suitable values taken into account.</i>	

Denso Flex - Bandumwicklung

Denso Flex - wrapping



Denso Flex ist ein kaltverarbeitbares Petrolatum-band, d.h. ein Vlies das mit einer beidseitig korrosionsschützenden Masse beschichtet ist. SAS Zuganker können mit diesem Petrolatumband umwickelt werden. Achtung: Mit Denso Flex umwickelte Gewindestäbe sind nicht schraubbar.

Denso Flex is a cold applied petrolatum tape, e.g. a double-sided coated fleece with a special corrosion material. SAS tie rods can be wrapped with this petrolatum tape. Warning: With Denso Flex wrapped thread bars are not threadable with couplers, nuts, etc.

Korrosionsschutzsysteme

Corrosion protection systems

Feuerverzinkung



Hot-dip galvanizing

Gewindestähle der Güten SAS 670/800 und SAS 500/550 bzw. 555/700 können feuerverzinkt werden. Eine maximale Schichtdicke von ca. 200 µm sollte auf Grund der Schraubbarkeit mit dem entsprechenden Zubehör nicht überschritten werden. Nach DIN EN ISO 1461 beträgt die örtliche Schichtdicke (Mindestwert) 70 µm und die durchschnittliche Schichtdicke (Mindestwert) 85 µm. Neben der DIN EN ISO 1461 erfolgt das Feuerverzinken der SAS Gewindestäbe nach BS 729 (EN ISO 1461) und ASTM A 123, 153, 767.

Thread bars of the steel grade SAS 670/800 and SAS 500/550 resp. 555/700 can be hot-dip galvanized. A maximum coating thickness of approx. 200 µm should not be exceeded because of the tradability with the accessories. Acc. DIN EN ISO 1461 the local coating thickness (minimum) is 70 µm and the average coating thickness (minimum) is 85 µm. In addition to the standard DIN EN ISO 1461 the hot-dip galvanizing of the SAS thread bars is in accordance with BS 729 (EN ISO 1461) and ASTM A 123, 153, 767.

Schrumpfschlauch



Heat shrink sleeves

Schrumpfschläuche in Kombination mit einem PE-Rohr als Schutz vor mechanischen Beanspruchungen sind ein dauerhaftes Korrosionsschutzsystem für SAS Zuganker. Schrumpfschläuche sind auf der Innenseite mit einem Korrosionsschutzkleber versehen. Mit Heißluft oder Infrarotbestrahlung ist der Schrumpfschlauch aufzuschrumpfen. Nach dem Schrumpfen muss die Wanddicke mindestens 1 mm betragen.

Heat shrink sleeves in combination with a PE-tube as a protection against mechanical stress are a permanent corrosion system for SAS tie rods. Heat shrink sleeves have a corrosion glue in the internal side. With heated air or infrared heat the heat shrink sleeve should be sheated. After shrinking the section thickness has to be minimum 1 mm.

Doppelter Korrosionsschutz (DCP)

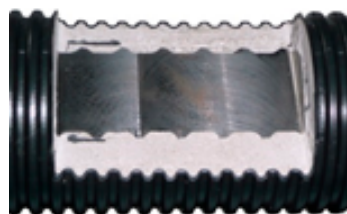

Double corrosion protection (DCP)

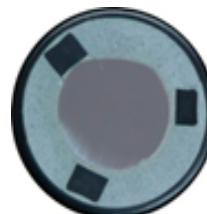

SAS Zuganker werden in einem Ripprohr liegend mit einem Zementmörtel ausinjiziert. Um die mittige Lage des Zugankers im Ripprohr zu gewährleisten, werden Abstandshalter eingesetzt. Doppelt- Korrosionsschutz Zuganker können auch in aggressiven Medien eingesetzt werden.

SAS tie rods in a corrugated duct are injected with a cement mortar. To guarantee the centric position of the tie rod in the corrugated duct, internal spacers are used. Double corrosion protected tie rods can be installed in aggressive environment.

Bemessungsbeispiel SAS Zuganker nach EAU 2014

Design example SAS Tie rods acc. to EAU 2014

Zuganker, Gurtbolzen, Gurtung der Hauptwand, Gurtung der Ankerwand.

Tie Rod, waling bolts, waling of the main wall, waling of the anchor wall.

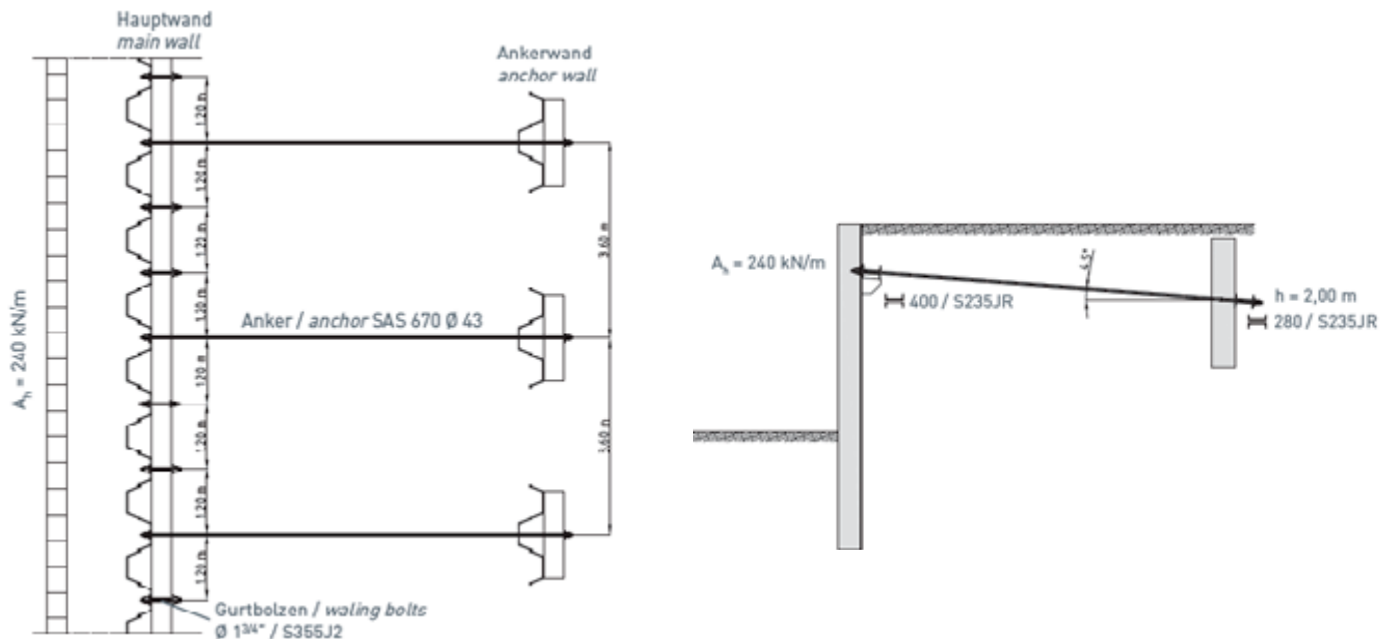

Berechnung und Bemessung der Spundwand	Calculation and design of sheet piling		Kapitel /chapter 8.2
Tragfähigkeitsnachweis Spundwandbauwerke	Bearing stability verification sheet piling structures		Kapitel/chapter 8.2.6
Rundstahlanker und Gurtbolzen	Tie rods and waling bolts		Kapitel /chapter 8.2.6.3
Vorgaben	Specifications		
Ankerabstand	tie rod distance	[a]	3,60 m
Bemessungswert der einwirkenden Last	design value of the load	[A _d]	240 kN/m
Ankerneigung	anchor angle	[α]	4,5°
1. Zuganker	1. Tie rod		
Bemessungswert der Einwirkung	design value of the action	[Z _d]	[kN]
$Z_d = A_d \cdot a / \cos \alpha = (240 \text{ kN/m} \cdot 3,60 \text{ m}) / \cos 4,5^\circ = 867 \text{ kN}$			
gewählter SAS Gewindestab als Zuganker	chosen SAS thread bar as tie rod	[Ø]	SAS 670/800 Ø 43
Querschnittsfläche	cross section area	[A]	1452 mm ²
Streckgrenze / Zugfestigkeit	yield stress / ultimate stress	[f _y /f _t]	670 N/mm ² / 800 N/mm ²
Bemessungswiderstand des SAS Zugankers	design resistance of the anchor	[R _d]	[kN]
$R_d = \min [F_{a,Rd}, F_{t,Rd}] = 884 \text{ kN}$			
Keine Reduzierung der Zugkraftbeanspruchbarkeit der SAS Zuganker durch Kerbfaktor!	No reduction of the tension strength of the SAS tie rod by a notch factor!		
Nachweis gegen Materialversagen	verification of material failure	[Z _d ≤ R _d]	
$Z_d \leq R_d = 867 \text{ kN} \leq 884 \text{ kN}$			
Nachweis gemäß EN 1993-5:2007+AC:2009 bzw. EAU 2012, Abschnitt 8.2.6.3 erfüllt	verification acc. to EN 1993-5:2007+AC:2009 resp. EAU 2012, chapter 8.2.6.3 fulfill	√	
2. Gurtbolzen	2. Waling bolts		
gewählter Gurtbolzenabstand	chosen distance of waling bolts	[e]	1,20 m
Bemessungswiderstand des Gurtbolzens	design resistance of waling bolt	[F _{d,G}]	240 kN/m
Bemessungswert Gurtbolzen	design value of waling bolts	[Z _{d,G}]	[kN]
$Z_{d,G} = Z_d \cdot e = 240 \text{ kN/m} \cdot 1,20 \text{ m} = 288 \text{ kN}$			
gewählter Gurtbolzen	chosen waling bolt		1 3/4"
gewählte Stahlgüte	chosen steel grade		S355J2+N
Querschnittsfläche Kern	cross section core	[A _s]	1131 mm ²
Streckgrenze	yield stress	[f _{y,s}]	355 N/mm ²
Bemessungswiderstand Gurtbolzen	design resistance waling bolt	[R _{d,G}]	[kN]
$R_{d,G} = A_s \cdot f_{y,s} / 1,10 = 1131 \text{ mm}^2 \cdot 355 \text{ N/mm}^2 / 1,10 = 365 \text{ kN}$			
Nachweis gegen Materialversagen	verification of material failure	[Z _{d,G} ≤ R _{d,G}]	
$Z_{d,G} \leq R_{d,G} = 288 \text{ kN} \leq 365 \text{ kN}$			
Nachweis gemäß EN 1993-5:2007+AC:2009 bzw. EAU 2012, Abschnitt 8.2.6.3 erfüllt	verification acc. to EN 1993-5:2007+AC:2009 resp. EAU 2012, chapter 8.2.6.3 fulfill	√	

Bemessungsbeispiel SAS Zuganker nach EAU 2014

Design example SAS Tie rods acc. to EAU 2014

Verankerungen, Aussteifungen	Anchors, stiffeners		Kapitel /chapter 8.4
Tragsicherheitsnachweise Spundwandgurte (E30)	Verification of bearing capacity (R30)		Kapitel/chapter 8.4.2
Ansatz der Einwirkungen	Loads for the calculation		Kapitel /chapter 8.4.2.3
Berechnungsweise	Method of calculation		Kapitel /chapter 8.4.2.4
3. Gurtung der Hauptwand			
3. Waling of the main wall			
max Moment im Gurt	max moment waling	$[M_{\max dGurt}]$	[kNm]
Bemessungswert der einwirkenden Last	design value of the load	$[q]$	240 $\frac{kN}{m}$
Ankerabstand	tie rod distance	$[a]$	3,60 m
$M_{\max dGurt} = q \cdot a^2/10 = 240 \frac{kN}{m} \cdot 3,60 m^2/10 = 311 \text{ kNm}$			
gewählte Gurtung	chosen waling] [400 U-profil
gewählte Stahlgüte	chosen steel grade		S235JR
Streckgrenze	yield stress	$[f_y]$	240 $\frac{N}{mm^2}$
Widerstandsmoment	moment of resistance	$[W_y]$	1020000 mm^3
zulässiges Moment	acceptable moment	$[M_{zul dGurt}]$	[kNm]
$M_{zul dGurt} = (f_y / \gamma) \cdot 2 \cdot W_y \cdot \gamma_1 / 1000000 = 240 \frac{N}{mm^2} / 1,1 \cdot 2 \cdot 1020000 mm^3 \cdot 0,85 / 1000000 = 378 \text{ kNm}$			
(Beanspruchung aus Schiffsstoß; Teilsicherheitsbeiwert für Widerstandsgrößen um 15% vergrößert)	(stress from vessel impact; partial safety factors for resistance be increased by 15%)	$\gamma = 1,1$	
Nachweis gegen Materialversagen	verification of material failure	$\gamma_1 = 0,85$	
$M_{zul dGurt} \leq M_{zul dGurt} = 311 \text{ kNm} \leq 378 \text{ kNm}$			
Nachweis gemäß EAU 2012, Abschnitt 8.4.2 erfüllt	verification acc. to EAU 2012, chapter 8.4.2 fulfill	√	
4. Gurtung der Ankerwand			
4. Waling of the anchor wall			
gewählte Ankerwand	chosen anchor wall		Dreifachbohlen/3-board
Ankerabstand	tie rod distance	$[a]$	3,60 m
Systemmaß	system dimension	$[c]$	1,20 m
Bemessungswert der einwirkenden Last	design value of the load	$[q]$	240 $\frac{kN}{m}$
max Moment im Gurt	max moment waling	$[M_{dw Gurt}]$	[kNm]
$M_{dw Gurt} = (q \cdot a \cdot c/3) / 2 = (240 \frac{kN}{m} \cdot 3,60 m \cdot 1,20 m \cdot 1/3) / 2 = 173 \text{ KNm}$			
gewählte Gurtung	chosen waling		Dreifachbohlen/3 board
gewählte Stahlgüte	chosen steel grade		S235JR
Streckgrenze	yield stress	$[f_y]$	240 N/mm^2
Widerstandsmoment	moment of resistance	$[W_y]$	2-448000 mm^3
zulässiges Moment	acceptable moment	$[M_{zul dw Gurt}]$	[kNm]
$M_{zul dw Gurt} = (f_y / \gamma) \cdot 2 \cdot W_y / 1000000 = 240 \frac{N}{mm^2} / 1,1 \cdot 2 \cdot 448000 mm^3 / 1000000 = 195 \text{ kNm}$			
Nachweis gegen Materialversagen	verification of material failure	$M_{zul dw Gurt} \leq M_{zul dw Gurt}$	
$M_{zul dw Gurt} \leq M_{zul dw Gurt} = 173 \text{ KNm} \leq 195 \text{ KNm}$			
Nachweis gemäß EAU 2012, Abschnitt 8.4.2 erfüllt	verification acc. to EAU 2012, chapter 8.4.2 fulfill	√	



Bemessungsbeispiel Bohrverpressanker

Design example ground anchor

Systemskizze
draft of system

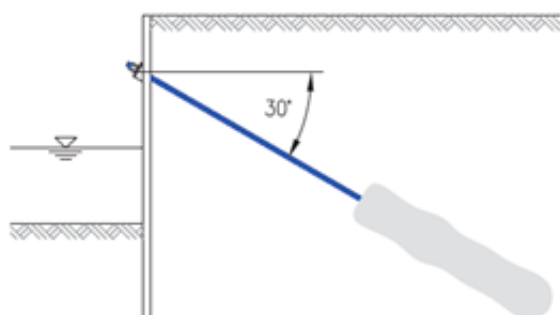













$A_{G,k}$ ständige Lasten
permanent loads



$A_{Q,k}$ veränderliche Lasten
variable loads



Berechnung und Bemessung des Verpressanker	Calculation of the ground anchor		
Einbauwinkel	installation angle	$[\alpha]$	30°
Bemessungswert der Einwirkung Last in Achsrichtung	design value of the load (axial direction)	$[A_d]$	[kN/m]
$A_d = A_{G,k} \times \gamma_G + A_{Q,k} \times \gamma_Q = (90 \text{ kN/m} \times 1,35 + 20,0 \text{ kN/m} \times 1,5) = 151,5 \text{ kN/m}$			
Ankerabstand	anchor distance	$[a]$	3,20 m
Bemessungswert der Einwirkung	design value of the anchor force	$[E_d]$	[kN]
$E_d = A_d \times a = 151,5 \text{ kN/m} \times 3,20 \text{ m} = 484,8 \text{ kN}$			
Stahlzugglied - Ø	steel tension rod - Ø		SAS 670/800 Ø35 mm
Querschnittsfläche	cross section area	$[A_s]$	962 mm ²
Teilsicherheitsbeiwert	partial safety factor	$[\gamma_M]$	1,15
DIN 1054:2005-01, Tab. 3 DIN 1054:2010-12, Tab. A2.3			
char. Spannung des Stahlzuggliedes	char. strength of the steel tension rod	$[f_{s,t,k}]$	[N/mm ²]
650 N/mm ² 0,1% permanent elongation			
Bemessungswert des Materialwiderstandes	design resistance of the material	$[R_{M,d}]$	[kN]
$R_{M,d} = A_s \cdot f_{s,t,k} / \gamma_M = 962 \text{ mm}^2 \times 650 \text{ N/mm}^2 / 1,15 = 543,7 \text{ kN}$			
Nachweis gegen Materialversagen	verification of material failure	$[E_d \leq R_{M,d}]$	
$E_d \leq R_{M,d} = 484,8 \text{ kN} \leq 543,7 \text{ kN}$			
Teilsicherheitsbeiwert für den Pfahlwiderstand	partial safety factor of the pile resistance	$[\gamma_p]$	1,40
Druck und Zug aufgrund von Erfahrungswerten	compression and tension due to experience		
Durchmesser des Verpresskörpers	diameter of the cement grout body	$[d]$	~250mm
char. Pfahlmantelreibung Sand und Kiessand	char. pile skin friction sand and gravel sand	$[q_{s,t,k}]$	0,15 MN/m ²
Erfahrungswerte nach DIN 1054:2010-12 vgl. DIN 1054:2005-01, Anhang D	experience acc. to DIN 1054:2010-12 and DIN 1054:2005-01, appendix D		
Bemessungswert der Pfahlmantelreibung	design resistance of the skin friction	$[T_d]$	[kN/m]
$T_d = q_{s,t,k} \times \pi \times d = 150 \text{ kN/m}^2 \times \pi \times 0,25 \text{ m} = 117,75 \text{ kN/m}$			
erforderliche Mindestverankerungslänge	required minimum length of anchorage	$[L]$	
$L_r = E_d \times \gamma_p / T_d = A_d \times a \times 1,40 / q_{s,t,k} \times \pi \times d = 151,5 \text{ kN/m} \times 3,20 \text{ m} \times 1,40 / 150 \text{ kN/m}^2 \times \pi \times 0,25 \text{ m} = 484,8 \text{ kN} \times 1,40 / 117,75 \text{ kN/m} = 5,76 \text{ m}$			

Streckgrenze / Zugfestigkeit <i>yield stress / ultimate stress</i>		Nenn- \varnothing <i>nom. -\varnothing</i>	Strecklast <i>yield load</i>	Bruchlast <i>ultimate load</i>	Fläche <i>cross section area</i>	Gewicht <i>weight</i>	Dehnung <i>elongation</i>				
Anwendungsbereiche / <i>areas of application</i>		[mm]	[kN]	[kN]	[mm ²]	[m/to]	[kg/m]	A _{gt} [%]	A ₁₀ [%]		
SAS 500 / 550 - grade 75											
 Bewehrungstechnik / <i>reinforcing systems</i>		12	57	62	113	1123,6	0,89	6	10		
		14	77	85	154	826,4	1,21				
		16	100	110	201	632,9	1,58				
		20	160	175	314	404,9	2,47				
		25	245	270	491	259,7	3,85				
 Geotechnik / <i>geotechnical systems</i>		28	310	340	616	207,0	4,83				
		32	405	440	804	158,5	6,31				
		36	510	560	1020	125,2	7,99				
		40	630	690	1260	101,3	9,87				
		43	726	799	1452	87,7	11,40				
	50	980	1080	1960	64,9	15,40					
SAS 555 / 700 - grade 80		57,5	1441	1818	2597	49,1	20,38	5	10		
SAS 555 / 700 - grade 80		63,5	1760	2215	3167	40,2	24,86	5	---		
SAS 500 / 550 - grade 75		75	2209	2430	4418	28,8	34,68	5	---		
<i>Alternativ SAS 550 erhältlich / alternative SAS 550 grade 75 available</i>											
SAS 450 / 700 - grade 60											
 Bergbau / <i>mining</i>		16	93	145	207	617,3	1,62		(A ₅) 15		
		25	220	345	491	259,7	3,85		(A ₅) 20		
SAS 650 / 800 - grade 90											
 Bergbau / <i>mining</i>		22	247	304	380	335,6	2,98	5	(A ₅) 18		
		25	319	393	491	259,7	3,85				
		28	400	493	616	207,0	4,83				
		30	460	565	707	180,2	5,55				
SAS 670 / 800 - grade 97											
 Geotechnik / <i>geotechnical systems</i>		18	170	204	254	500,0	2,00			5	10
		22	255	304	380	335,6	2,98				
		25	329	393	491	259,7	3,85				
		28	413	493	616	207,0	4,83				
 Ankertechnik / <i>tunneling & mining</i>		30	474	565	707	180,2	5,55				
		35	645	770	962	132,5	7,55				
		43	973	1162	1452	87,7	11,40				
		50	1315	1570	1963	64,9	15,40				
 Hochfeste Bewehrung / <i>high-strength reinforcement</i>		57,5	1740	2077	2597	49,1	20,38		---		
		63,5	2122	2534	3167	40,2	24,86		---		
		75	2960	3535	4418	28,8	34,68		---		
SAS 950 / 1050 - grade 150											
 Spanntechnik / <i>post-tensioning systems</i>		18	230	255	241	510,2	1,96	5	7		
		26,5	525	580	551	223,2	4,48				
		32	760	845	804	153,1	6,53				
		36	960	1070	1020	120,9	8,27				
 Geotechnik / <i>geotechnical systems</i>		40	1190	1320	1257	97,9	10,21				
		47	1650	1820	1735	70,9	14,10				
SAS 835 / 1035 - grade 150											
 Geotechnik / <i>geotechnical systems</i>		57	2155	2671	2581	47,7	20,95			4	---
		65	2780	3447	3331	36,9	27,10				---
		75	3690	4572	4418	27,9	35,90				---
SAS 900 / 1100 FA - grade 160 FA schweißbar / weldable											
 Schalungstechnik / <i>formwork ties</i>		15	159	195	177	694,4	1,44	3	7		
		20	283	345	314	390,6	2,56				
		26,5	495	606	551	223,2	4,48				
SAS 900 / 1050 FC - grade 150 FC											
 Schalungstechnik / <i>formwork ties</i>		15	159	186	177	694,4	1,44	3	7		
		20	283	330	314	390,6	2,56				
SAS 950 / 1050 E - grade 150		26,5	525	580	551	223,2	4,48	5	7		
SAS 750 / 875 FS - kaltgerollt / cold rolled - grade 120 FS schweißbar / weldable											
 Schalungstechnik / <i>formwork ties</i>		12,5	90	120	132,5	961,5	1,04	2	5,5		
		15	142	165	189	675,7	1,48				
		20	245	285	326	390,6	2,56				

Zubehör für alle Abmessungen und Anwendungen lieferbar / *accessories for all dimensions and applications available*