

# ASF-Anker

ANTON SCHMOLL GMBH



PRODUCT CATALOGUE  
**HYDRAULIC  
ENGINEERING**

[www.asf-anker.de](http://www.asf-anker.de)

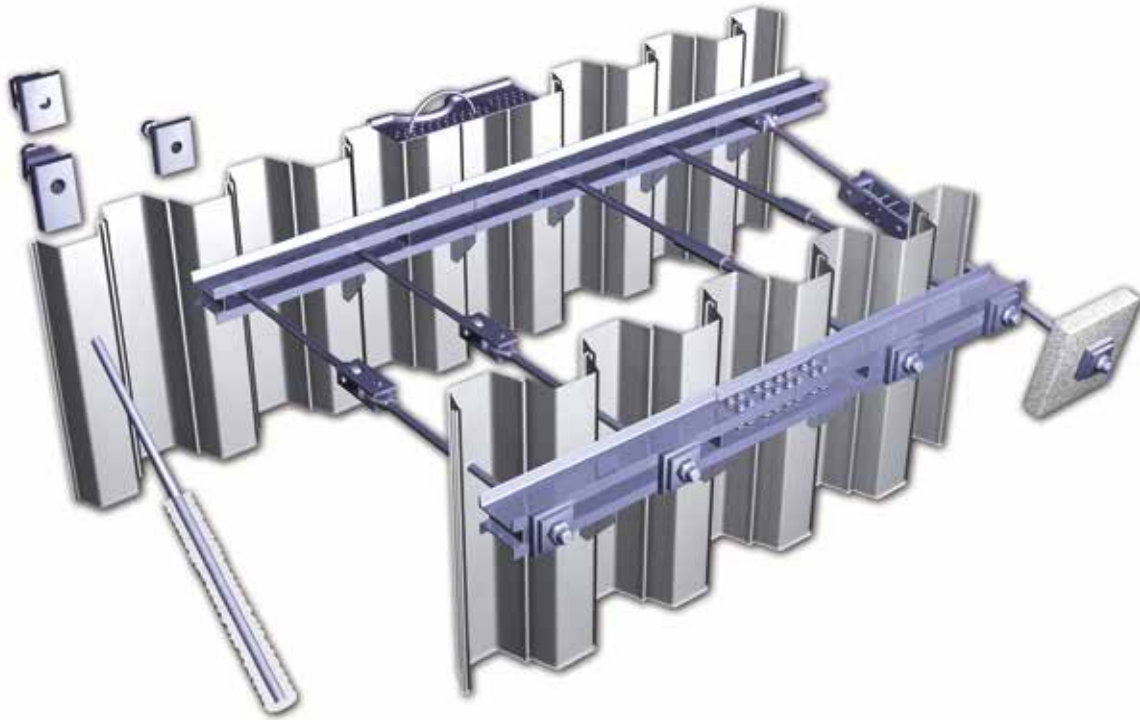

Quality management system certified to  
DIN EN ISO 9001:2015



Approved materials manufacturer to  
AD 2000-Merkblatt W0 and PED 97/23/EC



Occupational health and safety management system  
certified to BS OHSAS 18001:2007



Manufacturer's certificate for steel construction  
and hydraulic engineering to  
DIN EN 1090-1:2009+A1:2011 up to execution  
class EXC 4 and certificate for welding quality  
requirements to DIN EN ISO 3834-2:2006



Approved EN - 15048  
0045 - CPR - 1662

Certified factory production control  
(WPK gem. DIN EN 15048-1:2016) for the  
production of non-planned preloaded screw  
connections for metal construction

Zertifizierte Bauprodukte  
Certified construction products



ASF GmbH is entitled to label the majority  
of its products with the German conformity  
mark (Ü-mark) according to the German  
Conformity Directive  
(Übereinstimmungsverordnung)



Anchor approval for Russia  
to GOST-R TY ASF-679-10

## 1 Introduction

## 2 Anchorages

- + Design of anchorage elements
- + Overview of steel grades and Steel properties
- + Thread rolling
- + Corrosion protection
- + Anchors with upset and rolled threads to EAU 2012
- + Anchors with upset and rolled threads to DIN EN 1993-5
- + Anchors with rolled threads to IN EN 1993-5 – kt0,9

## 3 Connection elements Anchors

- + Anchor components
- + Turnbuckles
- + Couplers
- + Hinged turnbuckles

## 4 Waling joints Anchors

- + Introduction
- + Hexagonal nuts and Calotte nuts
- + Rocker plates and Threaded rocker plates
- + Anchor ball joints
- + rear plates ASF355
- + rear plates ASF460
- + rear plates ASF500
- + rear plates ASF600
- + rear plates ASF720
- + rear plates ASF900
- + Typical examples of complete systems

## 5 Eye tie rods

- + Eye tie rods ASF355 – ASF500 – ASF720

## 6 Connection elements Eye tie rods

- + Shackle joints
- + Universal joints for anchors
- + Universal joints at waling for anchors

## 7 Waling joints Eye tie rods

- + T-connections
- + Double T-connections
- + Anchor box

## 8 Grouted anchors

- + Introduction
- + Permissible design resistance

## 9 Waling

- + Introduction
- + Waling design
- + Waling bracket
- + Fixing waling
- + Waling bolt with head and nut
- + Waling stud with two nuts

## 10 Dockside equipment

- + Sheet pile wall capping
- + Vertical ladders
- + Bollards Part 1
- + Bollards Part 2
- + Inland Port bollards
- + Seaport bollards
- + Break-off anchorage for bollards

## 11 Dolphins, stairs and gangways

- + Dolphins
- + Gangways, stairs and stair towers

## 12 Appendix

- + Weight tables
- + List of directives used by us
- + Completed project
- + Contact



## Your partner for stability.

**For more than 90 years, ASF-ANKER ANTON SCHMOLL GMBH has been an established and well-known manufacturer of connecting elements for all conceivable construction applications.**

This technical product catalogue provides you with an overview of the most important and most used popular elements of our product range, and hence an insight into the state of the art. ASF-ANKER ANTON SCHMOLL GMBH is and remains an innovative company that always approaches the requirements of its customers always with interest and inquisitiveness therefore, if you should not find your desired product in this catalog, please do not hesitate to contact us, we will do our utmost to develop the product according to your specifications!

Modern anchorages employ area highly developed technologies that are frequently inconspicuous but always present. The range of possible fields of application illustrates this. The connecting elements

we produce are used time and time again in plants, structural and civil engineering, structural steelwork and hydraulic engineering. For hydraulic engineering projects, we can supply the steel piles, grouted anchors and a full range of anchorage components and dockside equipment for constructing sheet pile walls.

What that means in essence is: anchor and anchor components, anchor connecting elements, walings and waling fixings, sheet pile wall capping and protective nosing, equipment such as bollards and their fixings, ladders with grab bars, special items such as anchor connectors, sheet piles with impact strengthening, dolphins, gangways and stairs.

### Technology overview

Generous stocks of standard materials such as S 355 J2+N, 42CrMo4 and 34CrNiMo6 in lengths of up to 20 m ensure short delivery times. The maximum individual length that can be supplied is 35 m. Forged parts from M8 to M160 or 3/8 to 6 1/2 inch present no problems for our product area. Furthermore, we are able to fabricate anchors and tie rods (also with upset threads) in any length up to a maximum diameter of M160 or 6 1/2 inch with rolled threads. Machined threads are available in diameters of up to M180. And of course, we can carry out all conceivable drilling, milling, turning and welding work.

New in the program is the quality ASF720. In addition, you will find additional tables for upsed and rolled threads according to EAU 2012 and DIN EN 1993-5 as well as updated tables of the eye anchors, T-head anchors and connecting elements.

On request, we can also provide statically calculated front plates dimensions in sheet piling. Our technical department will be happy to advise you at any time!

Since July 2014, ASF has been certified to DIN EN 1090 – EXC4. This standard essentially regulates the conformity assessment procedure and the CE marking for steel loadbearing components and steel assemblies. ASF is therefore able to label the majority of the products it produces with the CE marking.

Furthermore, ASF has been certified according to EN 15048 since the beginning of 2016, so that connecting elements up to quality 10.9 can also be CE marked. A planning approval of the grouted anchor is due shortly and is expected soon.

Do you have any questions or comments about our catalog?  
Please do not hesitate to contact us directly by phone:  
+49 (0)2375 9186-0. We can certainly help you.

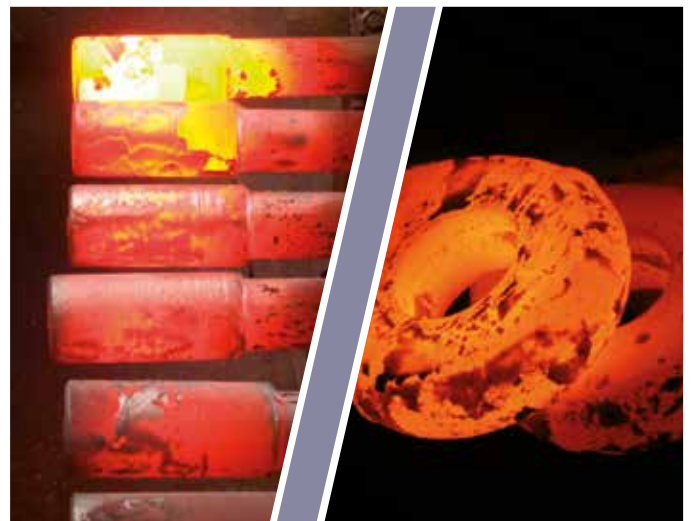

### ASF-Anker – tradition & high-tech

ASF-Anker Anton Schmoll GmbH was founded after the First World War and in its early years served as a subcontractor for domestic industries. Over the years, the stocks of materials and the range of plant grew, which enabled the company to enable its own, independent production.

The resulting problems in the area were solved in 1978 with the construction of a branch in the industrial area of Braukessiepen, which today is the main location. In 2010 an additional expansion took place in the new industrial area „Altes Feld“, 300 meters away. In the course of this, Anton Schmoll GmbH changed its name to today's company ASF-Anker Anton Schmoll GmbH.

In the meantime, more than 25,000 square meters of production and storage space with a hall capacity of more than 8,000 square meters are available, enabling the processing of unit weights of up to 32 tons.

# Witteveen + Bos

## Your plans on a secure footing

Security for your plans, the dependability of our products and the technical values given here are all very important matters for us.

We leave nothing to chance. Therefore, we have appointed Witteveen + Bos, a structural engineering and design office recognised throughout Europe, to carry out the calculations and check the technical information given here.

Of course, there are also other structural analyses that we will be happy to carry out for you.

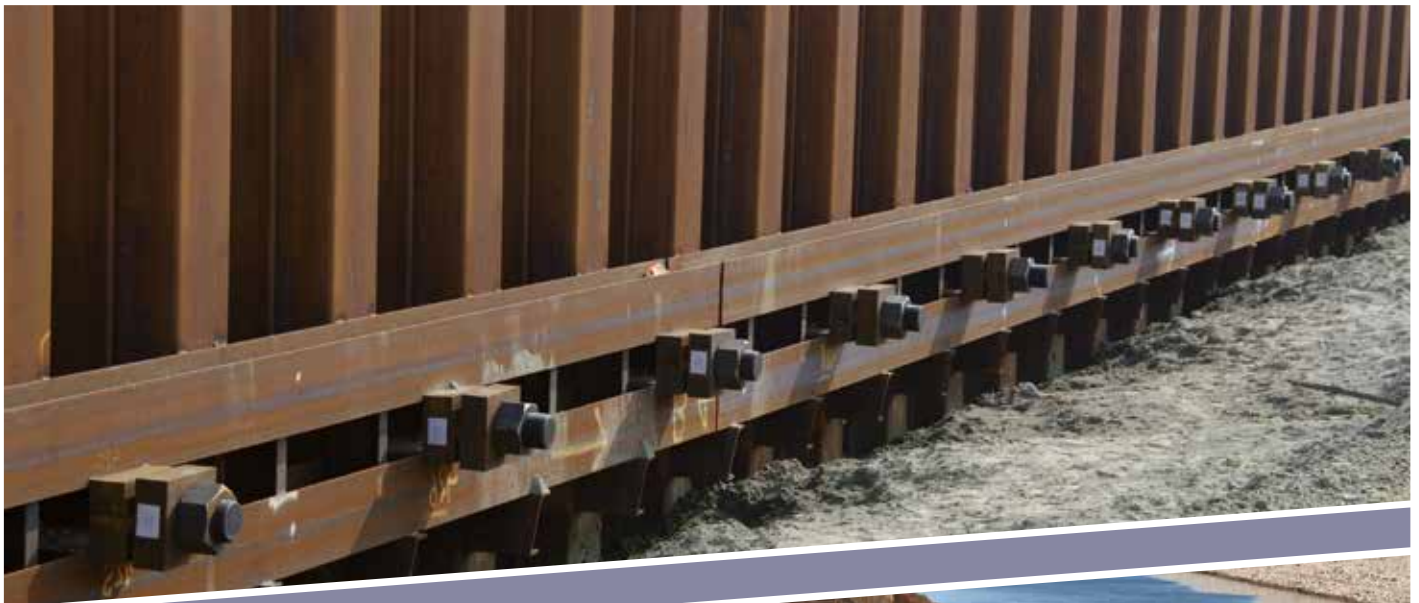

If the structural and constructional requirements placed on a sheet pile wall call for an anchorage, then propping the walls against each other is one way of doing this, e.g. in trenches for installing buried services.

However, in most cases the wall will have to be anchored back into the ground. Structural and constructional requirements dictate the choice and design of an anchorage. Critical for the design is the support reaction  $A$  resulting from the structural calculations for the sheet pile wall and the analysis of the lower slip plane.

The waling transfers the forces from the sheet pile wall to the anchor and at the same time helps to align and stiffen the wall. The anchor transfers the support reaction of the sheet pile wall via the waling to the anchorage itself.

And the task of the anchorage is to transfer the forces from the main wall to the subsoil. When using round steel tie rods, the anchorage is achieved with an anchor plate or anchor wall. When using anchor piles, e.g. driven steel piles, driven micropiles or grouted anchors, the force from the sheet pile wall is transferred to the subsoil via the skin friction of the pile.

## Design of anchorage elements

### Anchor wall, walings, capping beams and end plates

For predominantly constant loads, verification of structural safety must be carried out according to DIN EN 1993-5. Higher partial safety factors may need to be considered for walings and capping beams. In the case of predominantly varying loads, it is necessary to verify the fatigue strength to DIN 19704-1. EAU 2012, the Recommendations of the Committee for Waterfront Structures, Harbours & Waterways, should also be consulted.

Killed steels to DIN EN 10025 should generally be chosen. Closetolerance bolts, grade 4.6 or higher, should be used at bolted joints in walings and capping beams. Verification of fatigue strength must be carried out in accordance with DIN EN 1993-5.

### Round steel tie rods and waling bolts

Anchors are generally subjected to predominantly static loads. Significant fluctuating loads occur in anchors in certain instances only, but more frequently in waling bolts. Steels to DIN EN 10025 should be used for round steel tie rods and waling bolts. Steel grade S 355 J2+N is normally selected. The anchor forces due to the loads according to load case 2 should generally be used when designing for predominantly static loads. Verification of structural safety should be carried out to DIN EN 1993-5. The relevant reduction factors for load cases 1 to 3 should be taken into account.

DIN EN 14199 applies for the design and construction of sheet pile wall anchorages with grouted anchors. Only fully killed steels may be used in situations with predominantly fluctuating loads. Verification of structural safety should be carried out according to DIN EN 1993-5. If the basic static load is equal to or less than the amplitude of the reversed loading, the designer is recommended to prestress the anchors, or waling bolts, to a value higher than the amplitude of the stress in a controlled and permanent way.

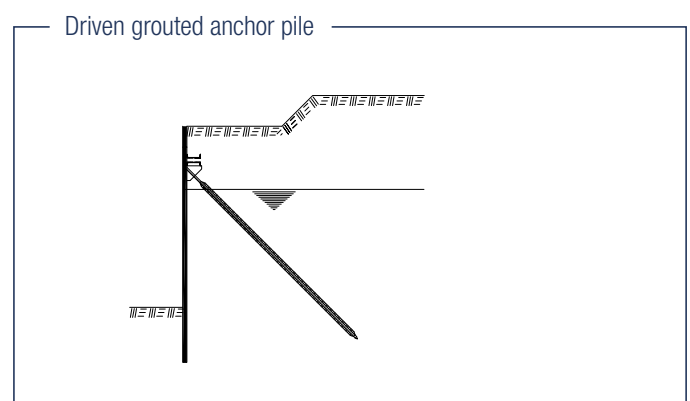
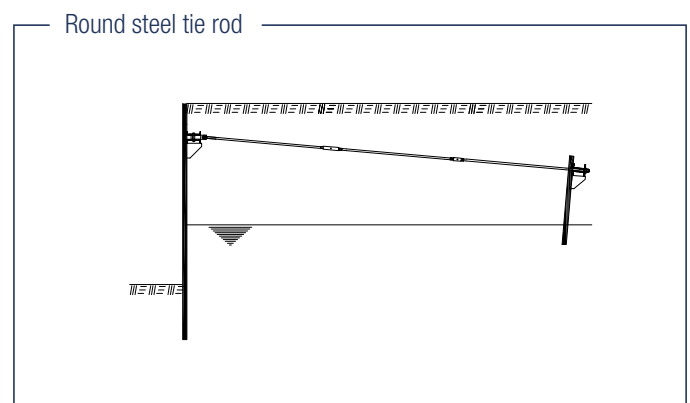
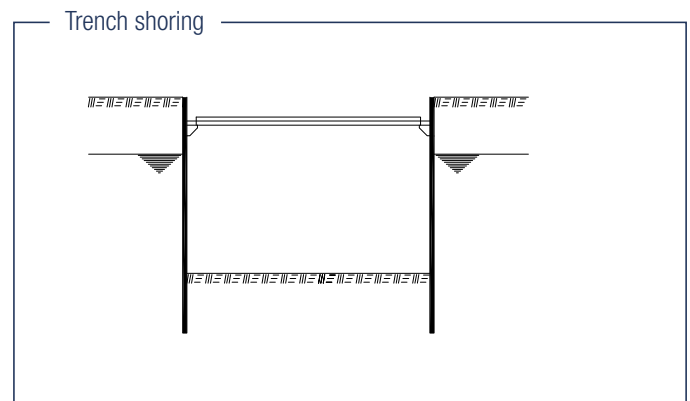

Round steel tie rods represent the most economic way of anchoring a sheet pile wall. Normally, the forces are transferred to anchor plates. When using concrete anchor plates, it is necessary to excavate as deep as the underside of the concrete element so that the plate can be installed. When using sheet pile plates or continuous anchor walls of sheet piles, it is only necessary to excavate to the depth of the anchor itself.

Round steel tie rods are mostly installed horizontally or at a very shallow angle because otherwise a deep anchor wall would require extensive excavations in order to connect the anchorage. The required length of the round steel tie rod depends on the analysis of the lower failure plane. The depth of the anchor plate is established by verifying the safety against failure of the soil in front of the plate.

## Overview of steel grades

Colour coding	Steel grade	Diameter $\varnothing D_1$	$F_y$ N/mm <sup>2</sup>	$F_{ua}$ N/mm <sup>2</sup>
	ASF355	M39 - M160	355	510
	ASF460	M39 - M160	460	640
	ASF500	M39 - M160	500	680
	ASF600	M39 - M160	600	900
	ASF720	M39 - M160	720	900
	ASF900	M39 - M160	900	1040

## Steel selection

All the steels we use are manufactured using the continuous casting method and rolled in the traditional manner. We do not use any TempCore steel because it tends to retain a soft core, especially with larger diameters.

## Advantages of continuous casting

Uniform material properties throughout the entire anchor cross-section.

## Minimum values

Yield stress ————  
**Example ASF 900:** minimum values 900 / 1040  
 Tensile strength/Breaking load ————

## Steel properties

### ASF355

- Minimum values: 355/510
- Classic quality structural steel proved over many years, regulated by EN 10025, available with CE marking
- Designed to EN 1993-5 with factors 1.0/1.25
- Forged materials available in all lengths
- Assembled products can be supplied with CE marking and declaration

### ASF460

- Minimum values: 460/640
- Fine-grained structural steel, regulated by EN 10025, available with CE marking
- Designed to EN 1993-5 with factors 1.0/1.25
- Represents the limit for easy-to-process steel grades to EN 1993-5
- Forged materials available in all lengths
- Assembled products can be supplied with CE marking and declaration

### ASF500

- Minimum values: 500/680
- Modified form of ASF460
- All further properties as for ASF460
- Assembled products can be supplied with CE marking and declaration

### ASF600

- Minimum values: 600/900
- AFP steel characterised by its large margin between yield stress and failure
- A steel designed for maximum force resistance, hence a kt value of 0.9
- Forged connection elements can be supplied in lengths of up to 5 m
- Calculations based on EN 1993-5 with factors 1.15/1.25
- EN 10267

### ASF 720

- Minimum values: 720/900
- Classic QT steel regulated in DIN EN 10083-1 and quenched and tempered to achieve grade 9.8 according to EN ISO 898-1
- Forged connection elements can be supplied in lengths of up to 12 m
- Calculations based on EN 1993-5 with factors 1.00/1.25
- CE marking possible

### ASF900

- Minimum values: 900/1040
- Classic QT steel regulated in DIN EN 10083-1 and quenched and tempered to achieve grade 10.9 according to EN ISO 898-1
- A steel designed for maximum force resistance, hence a kt value of 0.9
- Forged connection elements can be supplied in lengths of up to 5 m
- Calculations based on EN 1993-5 with factors 1.15/1.25
- CE marking possible

**Thread rolling**

All threads, especially upset thread sections, are rolled by us in our plant. We refrain from peeling the surface prior to rolling. That results in no interruptions to the fibres, which leads to additional work hardening of the surface.

Any length of thread is possible on a solid bar, even over the entire bar on request. Both metric and inch threads can be supplied. The use of inch threads and the associated coarser thread form results in simpler and faster progress on site.

We guarantee high-quality threads and fast fabrication.

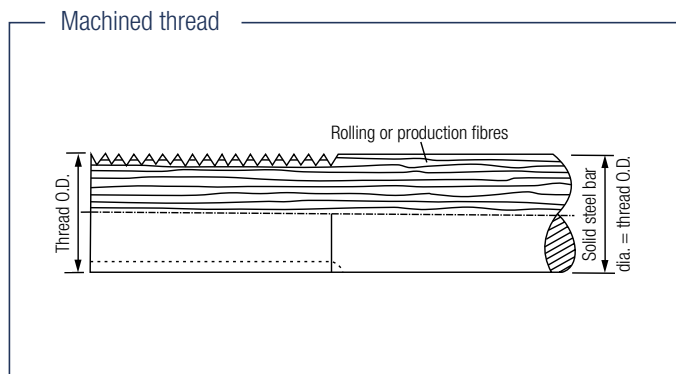
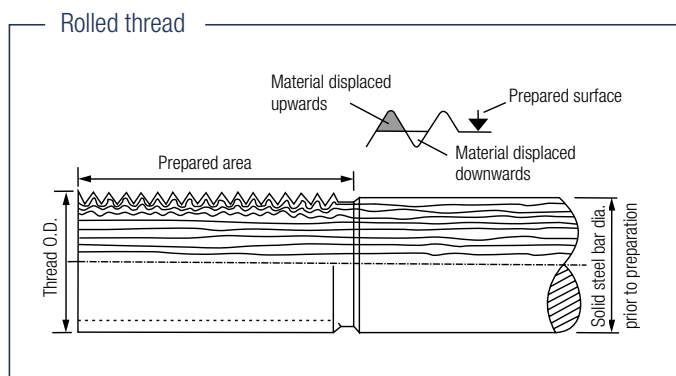

Advantages

- Rolled threads have a high profile accuracy.
- Thread rolling is akin to a cold-forming operation. This increases the strength of the steel and the yield stress at the root and flanks of the thread, which improves the concentric transfer of anchor forces via the thread.
- The root and flanks of a rolled thread are particularly smooth and therefore exhibit good durability in the case of dynamic loads.
- In contrast to machined threads, the fibres in the steel are not interrupted in rolled or hot-rolled threads.
- Nuts, couplers and turnbuckles for round steel tie rods with rolled threads do not necessarily have to have a rolled thread as well because internal threads are always subjected to lower stresses than external threads. Hoop tension forces are mobilised when internal threads are loaded and these support the thread. Therefore, combining rolled external threads on anchors with machined internal threads in nuts and turnbuckles does not represent a problem.

After rolling the thread, the outside diameter of the thread is larger than the diameter of the original steel bar. Therefore, the diameter, or upset diameter, of a round steel tie rod with a rolled thread can be smaller than that of an anchor with a machined thread for the same load-carrying capacity.



## The verification format for the ultimate limit state to DIN EN 1993-5 is:

$F_{t,Rd}$	=	Design tensile resistance of anchor thread
$F_{tq,Rd}$	=	Design tensile resistance of anchor shaft
$F_{yt,Rd}$	=	Design resistance at yield stress / 0.2% proof stress of anchor thread
$F_{yg,Rd}$	=	Design resistance at yield stress / 0.2% proof stress of anchor shaft
$K_t$	=	Notch factor
$F_{ua}$	=	Tensile strength of anchor
$F_y$	=	Yield stress of anchor
$A_s$	=	Stressed cross-sectional area, thread
$A_g$	=	Gross cross-sectional area, shaft
$\gamma_{M2}$	=	Partial safety factor for anchor shaft stressed up to failure
$\gamma_{M0}$	=	Partial safety factor for anchor shaft

## Corrosion protection

The simplest and least expensive way of achieving effective corrosion protection is to increase the diameter of the bar and the associated thread. The table below will help you decide whether increasing the size of the steel is worthwhile for your structure or whether a coating system would be more appropriate.

Please note that every coating increases the price per kilogram, prolongs the fabrication time for the anchor, is almost always damaged during transport and installation and from the environmental viewpoint is in some cases at least questionable.

## The design resistances are calculated using the following equations from EAU 2004, R 20, for the shaft and core cross-sections:

<b>Design resistance, thread:</b>	$F_{t,Rd} = \min(F_{t,Rd}; F_{yt,Rd})$
Failure in thread:	$F_{t,Rd} = k_t \cdot F_{ua} \cdot A_s / \gamma_{M2}$
Yield stress, thread:	$F_{yt,Rd} = F_y \cdot A_s / \gamma_{M0}$
<b>Design resistance, shaft:</b>	$F_{g,Rd} = \min(F_{tq,Rd}; F_{yg,Rd})$
Failure in shaft:	$F_{tq,Rd} = A_g \cdot F_{ua} / \gamma_{M2}$
Yield stress, shaft:	$F_{yg,Rd} = F_y \cdot A_g / \gamma_{M0}$
<b>Design resistance, anchor:</b>	$F_{u,Rd} = \min(F_{t,Rd}; F_{g,Rd})$

However, should you require coated anchor materials, then any form of coating is possible. All customary coating systems involving the application of paint on surfaces prepared by abrasive blasting can be applied.

Besides coating, the methods most frequently used are wrapping with Densoplast tape or hot-dip galvanising to EN ISO 1461 (except ASF600).

## Corrosion chart for steel anchors

EN 1993-5, Table 4-1 – Recommended values for loss of thickness [mm] due to corrosion in soils, with or without groundwater

## Required design working life

	5 Years	25 Years	50 Years	75 Years	100 Years
Non-compacted and non-aggressive fills (clay, slate, sand, silt)	0.18	0.7	1.2	1.7	2.2
Freshwater (river, canal, ...) in the region of the waterline	0.18	0.55	0.9	1.15	1.4
Severely polluted freshwater (wastewater, industrial wastewater) in the region of the waterline	0.3	1.3	2.3	3.3	4.3
Seawater in a temperate climate in the region of the waterline (low water and splash water zones)	0.55	1.9	3.75	5.6	7.5
Seawater in a temperate climate in the underwater or tidal zones	0.25	0.9	1.75	2.6	3.5

Note: For compacted fills, EN 1993-5 permits the corrosion rates to be halved.  
EN 1993-5, Table 4-2 – Recommended values for loss of thickness [mm]

Overall view anchor forces

Anchor force	ASF355 -EAU	ASF460 -EAU	ASF500 -EAU	ASF355 -0.6ups	ASF460 -0.6ups	ASF500 -0.6ups	ASF720 -0.6ups	ASF355 -0.9ups	ASF460 -0.9ups	ASF500 -0.9ups	ASF720 -0.9ups	ASF355 -0.9full	ASF460 -0.9full	ASF500 -0.9full	ASF720 -0.9full	ASF900 -0.9full
Norm	EAU ASF355	EAU ASF460	EAU ASF500	EN1993-5 ASF355	EN1993-5 ASF460	EN1993-5 ASF500	EN1993-5 ASF720	EN1993-5 ASF355	EN1993-5 ASF460	EN1993-5 ASF500	EN1993-5 ASF720	EN1993-5 ASF355	EN1993-5 ASF460	EN1993-5 ASF500	EN1993-5 ASF720	EN1993-5 ASF900
Typ	upset	upset	upset	upset	upset	upset	upset	upset	upset	upset	upset	upset	upset	upset	upset	full
kt	0,55	0,55	0,55	0,6	0,6	0,6	0,6	0,9	0,9	0,9	0,9	0,9	0,9	0,9	0,9	0,9
M / k <sub>a</sub>																
39	205	257	273	239	300	318	422	346	449	478	632	346	449	478	632	731
42	235	294	313	274	344	366	484	398	516	549	726	398	516	549	726	839
45	275	345	366	320	401	426	564	464	601	639	846	464	601	639	846	978
48	309	387	412	361	453	481	636	523	678	721	955	523	678	721	955	1103
52	366	465	494	403	522	567	759	424	550	597	860	424	550	597	861	1316
56	426	537	570	469	607	660	877	492	637	692	997	492	637	692	994	1520
60	491	627	666	540	699	760	1020	590	764	830	1196	590	764	830	1156	1769
64	560	709	754	616	798	867	1156	696	903	981	1413	696	903	981	1310	2004
68	634	813	864	697	903	982	1320	812	1053	1145	1649	812	1053	1145	1496	2288
72	739	924	982	813	1054	1129	1495	937	1215	1321	1902	937	1215	1321	1694	2591
76	824	1042	1107	906	1174	1269	1680	1071	1389	1509	2174	1071	1389	1509	1904	2912
80	912	1167	1240	1004	1301	1414	1877	1214	1574	1710	2463	1214	1574	1710	2127	3253
85	1038	1333	1416	1142	1480	1608	2138	1405	1821	1979	2850	1405	1821	1979	2423	3705
90	1172	1510	1605	1289	1671	1816	2415	1568	2032	2208	3180	1568	2032	2208	2737	4187
95	1351	1699	1805	1486	1925	2048	2710	1754	2312	2513	3619	1754	2312	2513	3071	4697
100	1503	1898	2017	1653	2142	2283	3022	2014	2610	2837	4085	2014	2610	2837	3425	5238
105	1663	2108	2240	1829	2370	2531	3350	2258	2926	3180	4580	2258	2926	3180	3797	5807
110	1831	2330	2476	2014	2610	2793	3696	2516	3260	3544	5103	2516	3260	3544	4189	6407
115	2008	2562	2723	2209	2862	3067	4059	2788	3613	3927	5655	2788	3613	3927	4600	7035
120	2192	2806	2981	2411	3125	3353	4438	3073	3983	4329	6234	3073	3983	4329	5030	7693
125	2385	3061	3252	2623	3399	3653	4835	3373	4371	4751	6842	3373	4371	4751	5479	8380
130	2586	3326	3534	2788	3613	3927	5248	3687	4778	5193	7478	3687	4778	5193	5948	9097
135	2795	3603	3828	3074	3983	4291	5679	4014	5202	5654	8142	4014	5202	5654	6436	9843
140	3011	3891	4134	3374	4356	4829	6126	4356	5645	6135	8835	4356	5645	6135	6943	10619
145	3237	4190	4452	3687	4687	4979	6591	4711	6106	6636	9557	4711	6106	6636	7469	11424
150	3529	4500	4781	4007	5029	5343	7072	5081	6584	7156	10305	5081	6584	7156	8015	12258
155	3835	4821	5122	4290	5383	5720	7570	5464	7081	7696	11083	5464	7081	7696	8580	13122
160	4088	5153	5475	4582	5750	6109	8085	5862	7596	8256	11889	5862	7596	8256	9163	14015

View anchor forces

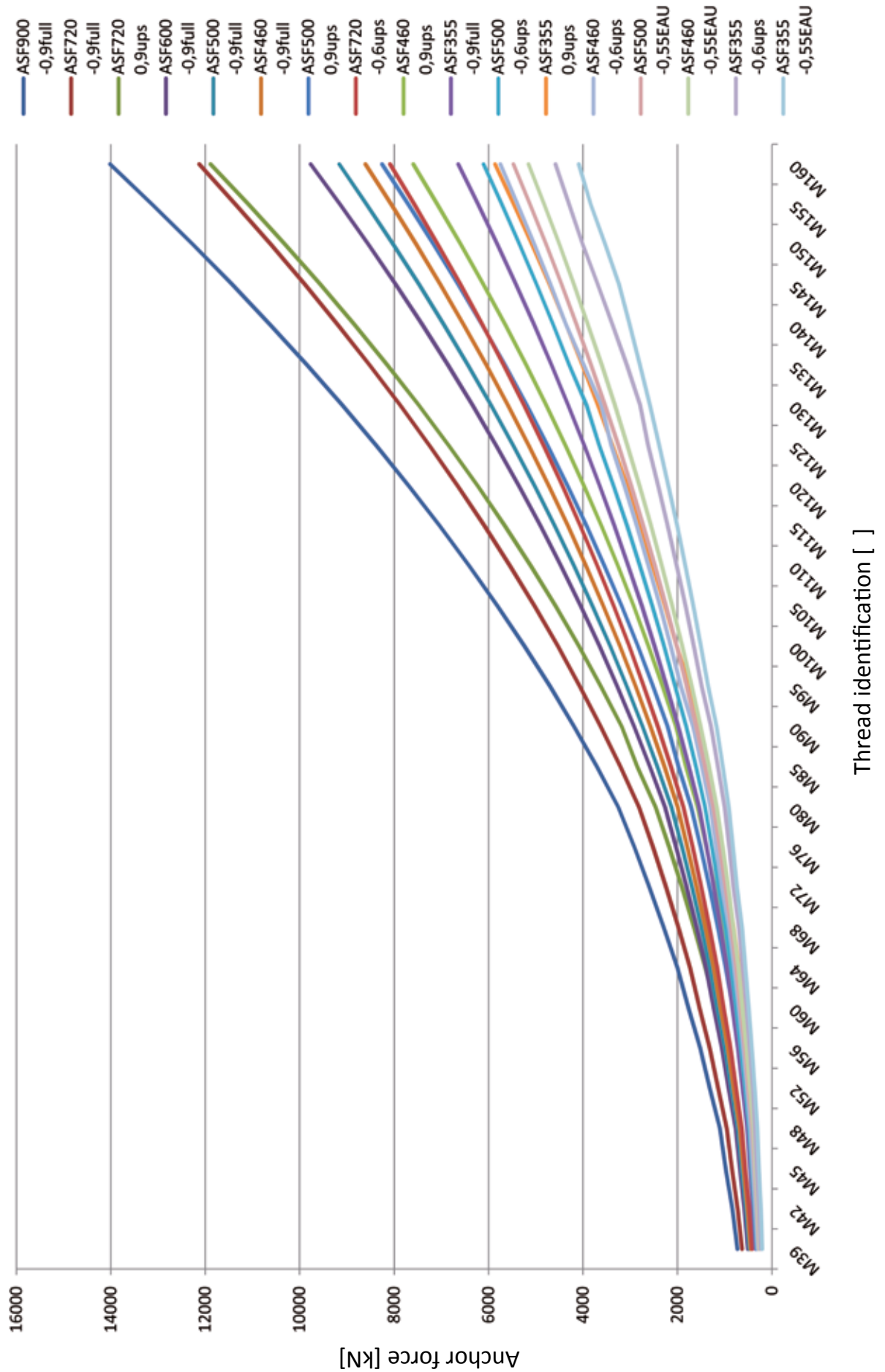

**Anchors with upset and rolled threads**

Round steel tie rods to EAU 2012

Nominal diameter	ØD1	Metric	M39	M42	M45	M48	M52	M56	M60	M64	M68	M72
Area, core diameter	A <sub>s</sub>	mm <sup>2</sup>	976	1121	1306	1473	1758	2030	2362	2676	3055	3460

ASF355-anchor force to EAU 2012-kt 0,55			M39	M42	M45	M48	M52	M56	M60	M64	M68	M72
Shaft diameter	d	mm	36	39	42	45	38	41	44	47	50	54
Area, shaft	A <sub>g</sub>	mm <sup>2</sup>	1017	1194	1385	1590	1134	1320	1521	1735	1963	2290
kt 0,55	Design resistance, shaft	F <sub>g,Rd</sub>	kN	328	385	447	513	366	426	491	560	634
	Design resistance, thread	F <sub>t,Rd</sub>	kN	205	235	275	309	371	428	500	565	648
	Permissible design resistance	F <sub>u,Rd</sub>	kN	205	235	275	309	366	426	491	560	634

ASF460-anchor force to EAU 2012-kt 0,55			M39	M42	M45	M48	M52	M56	M60	M64	M68	M72
Shaft diameter	d	mm	36	39	42	45	38	41	44	47	50	54
Area, shaft	A <sub>g</sub>	mm <sup>2</sup>	1017	1194	1385	1590	1134	1320	1521	1735	1963	2290
kt 0,55	Design resistance, shaft	F <sub>g,Rd</sub>	kN	425	499	579	665	474	552	636	726	821
	Design resistance, thread	F <sub>t,Rd</sub>	kN	257	294	345	387	465	537	627	709	813
	Permissible design resistance	F <sub>u,Rd</sub>	kN	257	294	345	387	465	537	627	709	813

ASF500-anchor force to EAU 2012-kt 0,55			M39	M42	M45	M48	M52	M56	M60	M64	M68	M72
Shaft diameter	d	mm	36	39	42	45	38	41	44	47	50	54
Area, shaft	A <sub>g</sub>	mm <sup>2</sup>	1017	1194	1385	1590	1134	1320	1521	1735	1963	2290
kt 0,55	Design resistance, shaft	F <sub>g,Rd</sub>	kN	462	542	629	723	516	600	691	789	892
	Design resistance, thread	F <sub>t,Rd</sub>	kN	273	313	366	412	494	570	666	754	864
	Permissible design resistance	F <sub>u,Rd</sub>	kN	273	313	366	412	494	570	666	754	864



Round steel tie rod components and connecting elements

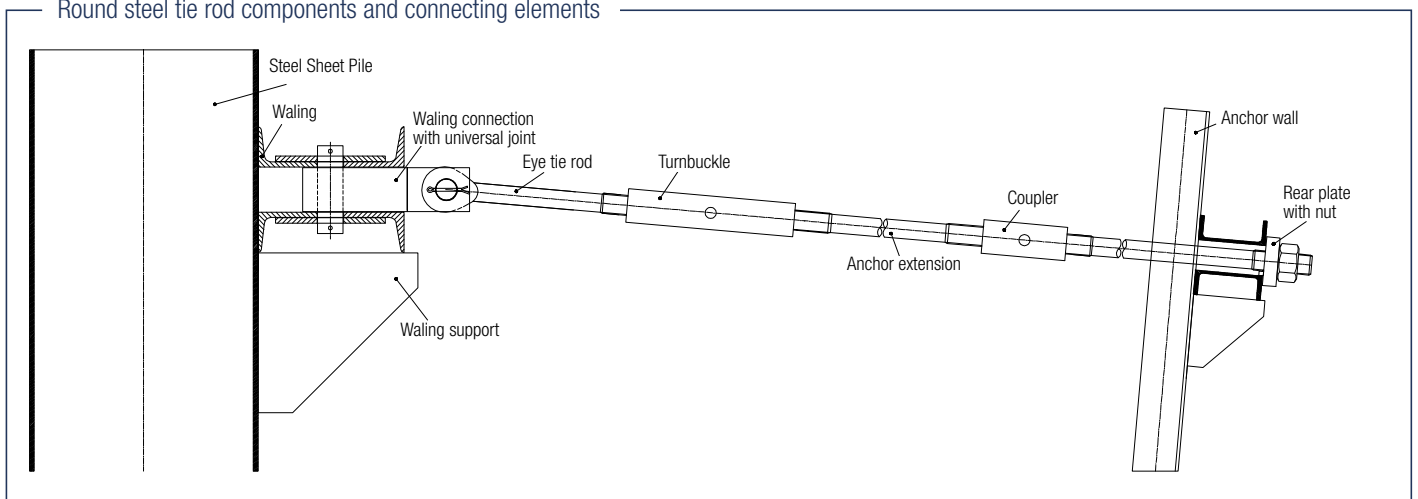

# 2

## ANCHORAGES

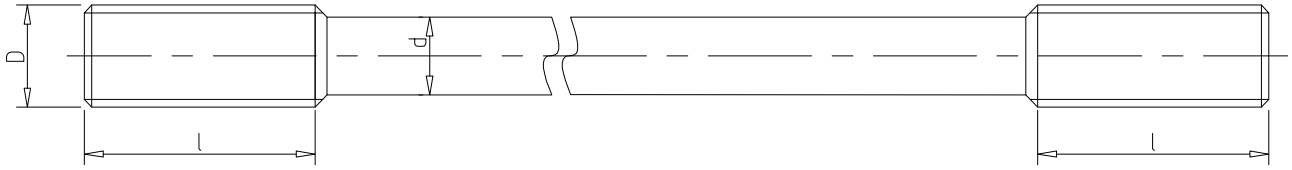

	M76	M80	M85	M90	M95	M100	M105	M110	M115	M120	M125	M130	M135	M140	M145	M150	M155	M160
	3889	4344	4948	5591	6273	6995	7755	8556	9395	10274	11191	12149	13145	14181	15256	16370	17524	18716

	M76	M80	M85	M90	M95	M100	M105	M110	M115	M120	M125	M130	M135	M140	M145	M150	M155	M160
	57	60	64	68	73	77	81	85	89	93	97	101	105	109	113	118	123	127
	2552	2827	3217	3632	4185	4657	5153	5675	6221	6793	7390	8012	8659	9331	10029	10936	11882	12668
	824	912	1038	1172	1351	1503	1663	1831	2008	2192	2385	2586	2795	3011	3237	3529	3835	4088
	830	930	1062	1204	1354	1512	1680	1857	2042	2236	2439	2651	2871	3101	3339	3586	3842	4106
	824	912	1038	1172	1351	1503	1663	1831	2008	2192	2385	2586	2795	3011	3237	3529	3835	4088

	M76	M80	M85	M90	M95	M100	M105	M110	M115	M120	M125	M130	M135	M140	M145	M150	M155	M160
	57	60	64	68	73	77	81	85	89	93	97	101	105	109	113	118	123	127
	2552	2827	3217	3632	4185	4657	5153	5675	6221	6793	7390	8012	8659	9331	10029	10936	11882	12668
	1067	1182	1345	1519	1750	1947	2155	2373	2602	2841	3090	3350	3621	3902	4194	4573	4969	5297
	1042	1167	1333	1510	1699	1898	2108	2330	2562	2806	3061	3326	3603	3891	4190	4500	4821	5153
	1042	1167	1333	1510	1699	1898	2108	2330	2562	2806	3061	3326	3603	3891	4190	4500	4821	5153

	M76	M80	M85	M90	M95	M100	M105	M110	M115	M120	M125	M130	M135	M140	M145	M150	M155	M160
	57	60	64	68	73	77	81	85	89	93	97	101	105	109	113	118	123	127
	2552	2827	3217	3632	4185	4657	5153	5675	6221	6793	7390	8012	8659	9331	10029	10936	11882	12668
	1160	1285	1462	1651	1902	2117	2342	2579	2828	3088	3359	3642	3936	4242	4559	4971	5401	5758
	1107	1240	1416	1605	1805	2017	2240	2476	2723	2981	3252	3534	3828	4134	4452	4781	5122	5475
	1107	1240	1416	1605	1805	2017	2240	2476	2723	2981	3252	3534	3828	4134	4452	4781	5122	5475



## Anchorages with upset and rolled threads

Round steel tie rods to DIN EN 1993-5

Nominal diameter	ØD1	Metric	M39	M42	M45	M48	M52	M56	M60	M64	M68	M72
Stressed area, thread	$A_s$	mm <sup>2</sup>	976	1121	1306	1473	1758	2030	2362	2676	3055	3460

ASF355-anchor force to EN 1993-5			M39	M42	M45	M48	M52	M56	M60	M64	M68	M72	
Shaft diameter	d	mm	36	39	42	45	38	41	44	47	50	54	
Area, shaft	$A_g$	mm <sup>2</sup>	1017	1194	1385	1590	1134	1320	1521	1735	1963	2290	
kt 0,6	Design resistance, shaft	$F_{g,Rd}$	kN	361	424	491	564	403	469	540	616	697	813
	Design resistance, thread	$F_{t,Rd}$	kN	239	274	320	361	430	497	578	655	748	847
	Permissible design resistance	$F_{u,Rd}$	kN	239	274	320	361	403	469	540	616	697	813

ASF355-anchor force to EN 1993-5			M39	M42	M45	M48	M52	M56	M60	M64	M68	M72	
Shaft diameter	d	mm	36	39	42	45	39	42	46	50	54	58	
Area, shaft	$A_g$	mm <sup>2</sup>	1017	1194	1385	1590	1195	1385	1661	1963	2290	2642	
kt 0,9	Design resistance, shaft	$F_{g,Rd}$	kN	361	424	492	564	424	492	590	696	812	937
	Design resistance, thread	$F_{t,Rd}$	kN	346	398	464	523	624	721	839	950	1085	1228
	Permissible design resistance	$F_{u,Rd}$	kN	346	398	464	523	424	492	590	696	812	937

ASF460-anchor force to EN1993-5			M39	M42	M45	M48	M52	M56	M60	M64	M68	M72	
Shaft diameter	d	mm	36	39	42	45	38	41	44	47	50	54	
Area, shaft	$A_g$	mm <sup>2</sup>	1017	1194	1385	1590	1134	1320	1521	1735	1963	2290	
kt 0,6	Design resistance, shaft	$F_{g,Rd}$	kN	425	499	579	665	522	607	699	798	903	1054
	Design resistance, thread	$F_{t,Rd}$	kN	300	344	401	453	540	624	726	822	939	1063
	Permissible design resistance	$F_{u,Rd}$	kN	300	344	401	453	522	607	699	798	903	1054

ASF460-anchor force to EN1993-5			M39	M42	M45	M48	M52	M56	M60	M64	M68	M72	
Shaft diameter	d	mm	36	39	42	45	39	42	46	50	54	58	
Area, shaft	$A_g$	mm <sup>2</sup>	1017	1194	1385	1590	1195	1385	1661	1963	2290	2642	
kt 0,9	Design resistance, shaft	$F_{g,Rd}$	kN	468	550	637	731	550	637	764	903	1053	1215
	Bemessungswiderstand Gewinde	$F_{t,Rd}$	kN	449	516	601	678	809	934	1087	1231	1405	1592
	Permissible design resistance	$F_{u,Rd}$	kN	449	516	601	678	550	637	764	903	1053	1215



# 2

## ANCHORAGES

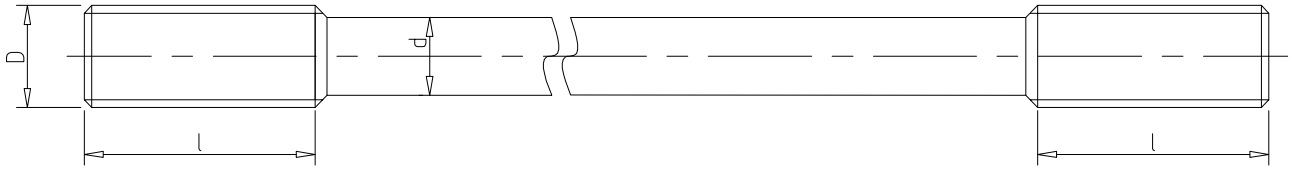

M76	M80	M85	M90	M95	M100	M105	M110	M115	M120	M125	M130	M135	M140	M145	M150	M155	M160
3889	4344	4948	5591	6273	6995	7755	8556	9395	10274	11191	12149	13145	14181	15256	16370	17524	18716

M76	M80	M85	M90	M95	M100	M105	M110	M115	M120	M125	M130	M135	M140	M145	M150	M155	M160
57	60	64	68	73	77	81	85	89	93	97	100	105	110	115	120	125	130
2552	2827	3217	3632	4185	4657	5153	5675	6221	6793	7390	7854	8659	9503	10387	11310	12272	13273
906	1004	1142	1289	1486	1653	1829	2014	2209	2411	2623	2788	3074	3374	3687	4015	4357	4712
952	1063	1211	1369	1536	1712	1899	2094	2300	2515	2740	2974	3218	3471	3735	4007	4290	4582
906	1004	1142	1289	1486	1653	1829	2014	2209	2411	2623	2788	3074	3374	3687	4007	4290	4582

M76	M80	M85	M90	M95	M100	M105	M110	M115	M120	M125	M130	M135	M140	M145	M150	M155	M160
62	66	71	75	80	85	90	95	100	105	110	115	120	125	130	135	140	145
3019	3421	3959	4417	5026	5674	6361	7088	7854	8659	9503	10386	11309	12271	13273	14313	15393	16513
1071	1214	1405	1568	1784	2014	2258	2516	2788	3073	3373	3687	4014	4356	4711	5081	5464	5862
1381	1542	1756	1985	2227	2483	2753	3037	3335	3647	3973	4313	4666	5034	5416	5811	6221	6644
1071	1214	1405	1568	1754	2014	2258	2516	2788	3073	3373	3687	4014	4356	4711	5081	5464	5862

M76	M80	M85	M90	M95	M100	M105	M110	M115	M120	M125	M130	M135	M140	M145	M150	M155	M160
57	60	64	68	73	77	81	85	89	93	97	100	105	110	115	120	125	130
2552	2827	3217	3632	4185	4657	5153	5675	6221	6793	7390	7854	8659	9503	10387	11310	12272	13273
1174	1301	1480	1671	1925	2142	2370	2610	2862	3125	3399	3613	3983	4372	4778	5202	5645	6106
1195	1334	1520	1717	1927	2149	2382	2628	2886	3156	3438	3732	4038	4356	4687	5029	5383	5750
1174	1301	1480	1671	1925	2142	2370	2610	2862	3125	3399	3613	3983	4356	4687	5029	5383	5750

M76	M80	M85	M90	M95	M100	M105	M110	M115	M120	M125	M130	M135	M140	M145	M150	M155	M160
62	66	71	75	80	85	90	95	100	105	110	115	120	125	130	135	140	145
3019	3421	3959	4417	5026	5674	6361	7088	7854	8659	9503	10386	11309	12271	13273	14313	15393	16513
1389	1574	1821	2032	2312	2610	2926	3260	3613	3983	4371	4778	5202	5645	6106	6584	7081	7596
1789	1998	2276	2572	2886	3218	3567	3936	4322	4726	5148	5588	6047	6523	7018	7530	8061	8609
1389	1574	1821	2032	2312	2610	2926	3260	3613	3983	4371	4778	5202	5645	6106	6584	7081	7596



## Anchorages with upset and rolled threads

Round steel tie rods to DIN EN 1993-5

Nominal diameter	ØD1	Metric	M39	M42	M45	M48	M52	M56	M60	M64	M68	M72
Stressed area, thread	$A_s$	mm <sup>2</sup>	976	1121	1306	1473	1758	2030	2362	2676	3055	3460

ASF500-anchor force to EN 1993-5			M39	M42	M45	M48	M52	M56	M60	M64	M68	M72
Shaft diameter	d	mm	36	39	42	45	38	41	44	47	50	54
Area, shaft	$A_g$	mm <sup>2</sup>	1017	1194	1385	1590	1134	1320	1521	1735	1963	2290
kt 0,6	Design resistance, shaft	$F_{g,Rd}$	508	597	692	795	567	660	760	867	982	1145
	Design resistance, thread	$F_{t,Rd}$	318	366	426	481	574	663	771	873	997	1129
	Permissible design resistance	$F_{u,Rd}$	318	366	426	481	567	660	760	867	982	1129

ASF500-anchor force to EN 1993-5			M39	M42	M45	M48	M52	M56	M60	M64	M68	M72
Shaft diameter	d	mm	36	39	42	45	39	42	46	50	54	58
Area, shaft	$A_g$	mm <sup>2</sup>	1017	1194	1385	1590	1195	1385	1661	1963	2290	2642
kt 0,9	Design resistance, shaft	$F_{g,Rd}$	509	597	692	795	597	692	830	981	1145	1321
	Design resistance, thread	$F_{t,Rd}$	478	549	639	721	861	994	1156	1310	1496	1694
	Permissible design resistance	$F_{u,Rd}$	478	549	639	721	597	692	830	981	1145	1321

ASF720-anchor force to EN1993-5			M39	M42	M45	M48	M52	M56	M60	M64	M68	M72
Shaft diameter	d	mm	36	39	42	45	38	41	44	47	50	54
Area, shaft	$A_g$	mm <sup>2</sup>	1017	1194	1385	1590	1134	1320	1521	1735	1963	2290
kt 0,6	Design resistance, shaft	$F_{g,Rd}$	732	860	997	1145	817	950	1095	1249	1413	1649
	Design resistance, thread	$F_{t,Rd}$	422	484	564	636	759	877	1020	1156	1320	1495
	Permissible design resistance	$F_{u,Rd}$	422	484	564	636	759	877	1020	1156	1320	1495

ASF720-anchor force to EN1993-5			M39	M42	M45	M48	M52	M56	M60	M64	M68	M72
Shaft diameter	d	mm	36	39	42	45	39	42	46	50	54	58
Area, shaft	$A_g$	mm <sup>2</sup>	1017	1194	1385	1590	1195	1385	1661	1963	2290	2642
kt 0,9	Design resistance, shaft	$F_{g,Rd}$	733	860	997	1145	860	997	1196	1413	1649	1902
	Design resistance, thread	$F_{t,Rd}$	632	726	846	955	1139	1315	1531	1734	1980	2242
	Permissible design resistance	$F_{u,Rd}$	632	726	846	955	860	997	1196	1413	1649	1902



# 2

## ANCHORAGES

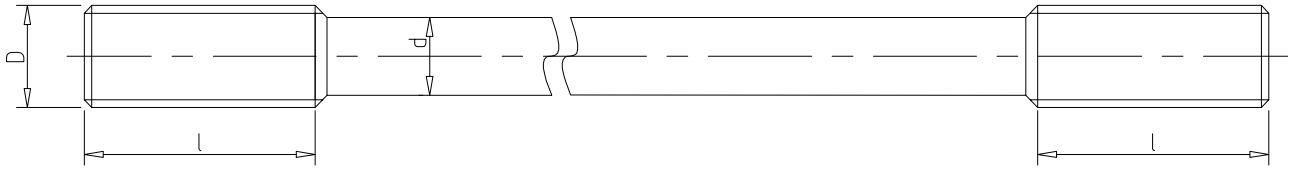

M76	M80	M85	M90	M95	M100	M105	M110	M115	M120	M125	M130	M135	M140	M145	M150	M155	M160
3889	4344	4948	5591	6273	6995	7755	8556	9395	10274	11191	12149	13145	14181	15256	16370	17524	18716

M76	M80	M85	M90	M95	M100	M105	M110	M115	M120	M125	M130	M135	M140	M145	M150	M155	M160
57	60	64	68	73	77	81	85	89	93	97	100	105	110	115	120	125	130
2552	2827	3217	3632	4185	4657	5153	5675	6221	6793	7390	7854	8659	9503	10387	11310	12272	13273
1276	1414	1608	1816	2093	2328	2576	2837	3111	3396	3695	3927	4330	4752	5193	5655	6136	6637
1269	1418	1615	1825	2048	2283	2531	2793	3067	3353	3653	3965	4291	4629	4979	5343	5720	6109
1269	1414	1608	1816	2048	2283	2531	2793	3067	3353	3653	3927	4291	4629	4979	5343	5720	6109

M76	M80	M85	M90	M95	M100	M105	M110	M115	M120	M125	M130	M135	M140	M145	M150	M155	M160
62	66	71	75	80	85	90	95	100	105	110	115	120	125	130	135	140	145
3019	3421	3959	4417	5026	5674	6361	7088	7854	8659	9503	10386	11309	12271	13273	14313	15393	16513
1509	1710	1979	2208	2513	2837	3180	3544	3927	4329	4751	5193	5654	6135	6636	7156	7696	8256
1904	2127	2422	2737	3071	3425	3797	4189	4600	5030	5479	5948	6436	6943	7469	8015	8580	9163
1509	1710	1979	2208	2513	2837	3180	3544	3927	4329	4751	5193	5654	6135	6636	7156	7696	8256

M76	M80	M85	M90	M95	M100	M105	M110	M115	M120	M125	M130	M135	M140	M145	M150	M155	M160
57	60	64	68	73	77	81	85	89	93	97	100	105	110	115	120	125	130
2552	2827	3217	3632	4185	4657	5153	5675	6221	6793	7390	7854	8659	9503	10387	11310	12272	13273
1837	2035	2316	2615	3013	3353	3710	4086	4479	4891	5321	5655	6234	6842	7479	8143	8836	9557
1680	1877	2138	2415	2710	3022	3350	3696	4059	4438	4835	5248	5679	6126	6591	7072	7570	8085
1680	1877	2138	2415	2710	3022	3350	3696	4059	4438	4835	5248	5679	6126	6591	7072	7570	8085

M76	M80	M85	M90	M95	M100	M105	M110	M115	M120	M125	M130	M135	M140	M145	M150	M155	M160
62	66	71	75	80	85	90	95	100	105	110	115	120	125	130	135	140	145
3019	3421	3959	4417	5026	5674	6361	7088	7854	8659	9503	10386	11309	12271	13273	14313	15393	16513
2174	2463	2850	3180	3619	4085	4580	5103	5655	6234	6842	7478	8142	8835	9557	10305	11083	11889
2520	2815	3206	3623	4065	4533	5025	5544	6088	6658	7252	7873	8518	9189	9886	10608	11356	12128
2174	2463	2850	3180	3619	4085	4580	5103	5655	6234	6842	7478	8142	8835	9557	10305	11083	11889



**Anchors with rolled threads**

Round steel tie rods to DIN EN 1993-5

Nominal diameter	ØD1	Metric	M39	M42	M45	M48	M52	M56	M60	M64	M68	M72
Stressed area, thread	A <sub>s</sub>	mm <sup>2</sup>	976	1121	1306	1473	1758	2030	2362	2676	3055	3460

ASF355-anchor force to EN 1993-5			M39	M42	M45	M48	M52	M56	M60	M64	M68	M72	
Shaft diameter	d	mm	36	39	42	45	49	52	56	60	64	68	
Area, shaft	A <sub>g</sub>	mm <sup>2</sup>	1017	1194	1385	1590	1847	2124	2463	2827	3217	3632	
kt 0,9	Design resistance, shaft	F <sub>g,Rd</sub>	kN	361	424	492	564	656	754	874	1004	1142	1289
	Design resistance, thread	F <sub>t,Rd</sub>	kN	346	398	464	523	624	721	839	950	1085	1228
	Permissible design resistance	F <sub>u,Rd</sub>	kN	346	398	464	523	624	721	839	950	1085	1228

ASF460-anchor force to EN 1993-5			M39	M42	M45	M48	M52	M56	M60	M64	M68	M72	
Shaft diameter	d	mm	36	39	42	45	49	52	56	60	64	68	
Area, shaft	A <sub>g</sub>	mm <sup>2</sup>	1017	1194	1385	1590	1847	2124	2463	2827	3217	3632	
kt 0,9	Design resistance, shaft	F <sub>g,Rd</sub>	kN	468	550	637	731	850	977	1133	1300	1480	1671
	Design resistance, thread	F <sub>t,Rd</sub>	kN	449	516	601	678	809	934	1087	1231	1405	1592
	Permissible design resistance	F <sub>u,Rd</sub>	kN	449	516	601	678	809	934	1087	1231	1405	1592

ASF500-anchor force to EN 1993-5			M39	M42	M45	M48	M52	M56	M60	M64	M68	M72	
Shaft diameter	d	mm	36	39	42	45	49	52	56	60	64	68	
Area, shaft	A <sub>g</sub>	mm <sup>2</sup>	1017	1194	1385	1590	1847	2124	2463	2827	3217	3632	
kt 0,9	Design resistance, shaft	F <sub>g,Rd</sub>	kN	509	598	693	795	924	1062	1232	1414	1609	1816
	Design resistance, thread	F <sub>t,Rd</sub>	kN	478	549	639	721	861	994	1156	1310	1496	1694
	Permissible design resistance	F <sub>u,Rd</sub>	kN	478	549	639	721	861	994	1156	1310	1496	1694

ASF600-anchor force to EN 1993-5			M39	M42	M45	M48	M52	M56	M60	M64	M68	M72	
Shaft diameter	d	mm	36	39	42	45	49	52	56	60	64	68	
Area, shaft	A <sub>g</sub>	mm <sup>2</sup>	1017	1194	1385	1590	1847	2124	2463	2827	3217	3632	
kt 0,9	Design resistance, shaft	F <sub>g,Rd</sub>	kN	531	623	723	830	964	1108	1285	1475	1678	1895
	Design resistance, thread	F <sub>t,Rd</sub>	kN	509	585	681	769	917	1059	1232	1396	1594	1805
	Permissible design resistance	F <sub>u,Rd</sub>	kN	509	585	681	769	917	1059	1232	1396	1594	1805

ASF720-anchor force to EN 1993-5			M39	M42	M45	M48	M52	M56	M60	M64	M68	M72	
Shaft diameter	d	mm	36	39	42	45	49	52	56	60	64	68	
Area, shaft	A <sub>g</sub>	mm <sup>2</sup>	1017	1194	1385	1590	1847	2124	2463	2827	3217	3632	
kt 0,9	Design resistance, shaft	F <sub>g,Rd</sub>	kN	733	860	997	1145	1330	1529	1773	2035	2316	2615
	Design resistance, thread	F <sub>t,Rd</sub>	kN	632	726	846	955	1139	1315	1531	1734	1980	2242
	Permissible design resistance	F <sub>u,Rd</sub>	kN	632	726	846	955	1139	1315	1531	1734	1980	2242

ASF900-anchor force to EN 1993-5			M39	M42	M45	M48	M52	M56	M60	M64	M68	M72	
Shaft diameter	d	mm	36	39	42	45	49	52	56	60	64	68	
Area, shaft	A <sub>g</sub>	mm <sup>2</sup>	1017	1194	1385	1590	1847	2124	2463	2827	3217	3632	
kt 0,9	Design resistance, shaft	F <sub>g,Rd</sub>	kN	797	935	1084	1244	1445	1662	1928	2212	2518	2842
	Design resistance, thread	F <sub>t,Rd</sub>	kN	731	839	978	1103	1316	1520	1769	2004	2288	2591
	Permissible design resistance	F <sub>u,Rd</sub>	kN	731	839	978	1103	1316	1520	1769	2004	2288	2591

# 2

# ANCHORAGES

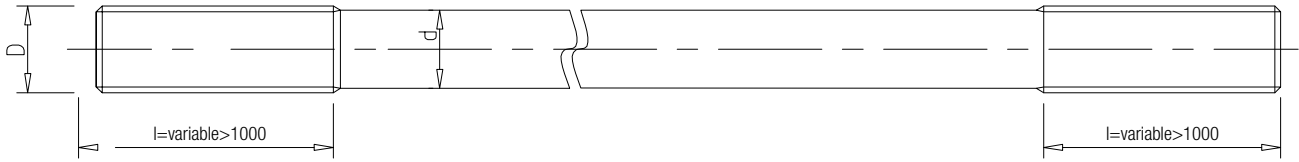

	M76	M80	M85	M90	M95	M100	M105	M110	M115	M120	M125	M130	M135	M140	M145	M150	M155	M160
	3889	4344	4948	5591	6273	6995	7755	8556	9395	10274	11191	12149	13145	14181	15256	16370	17524	18716
	M76	M80	M85	M90	M95	M100	M105	M110	M115	M120	M125	M130	M135	M140	M145	M150	M155	M160
	72	76	81	86	91	96	101	106	111	116	121	126	131	136	141	146	151	156
	4072	4536	5153	5809	6504	7238	8012	8825	9677	10568	11499	12469	13478	14527	15615	16742	17908	19113
	1446	1610	1829	2062	2309	2569	2844	3133	3435	3752	4082	4426	4785	5157	5543	5943	6357	6785
	1381	1542	1757	1985	2227	2483	2753	3037	3335	3647	3973	4313	4666	5034	5416	5811	6221	6644
	1381	1542	1757	1985	2227	2483	2753	3037	3335	3647	3973	4313	4666	5034	5416	5811	6221	6644
	M76	M80	M85	M90	M95	M100	M105	M110	M115	M120	M125	M130	M135	M140	M145	M150	M155	M160
	72	76	81	86	91	96	101	106	111	116	121	126	131	136	141	146	151	156
	4072	4536	5153	5809	6504	7238	8012	8825	9677	10568	11499	12469	13478	14527	15615	16742	17908	19113
	1873	2087	2370	2672	2992	3329	3686	4060	4451	4861	5290	5736	6200	6682	7183	7701	8238	8792
	1789	1998	2276	2572	2886	3218	3567	3936	4322	4726	5148	5589	6047	6523	7018	7530	8061	8609
	1789	1998	2276	2572	2886	3218	3567	3936	4322	4726	5148	5589	6047	6523	7018	7530	8061	8609
	M76	M80	M85	M90	M95	M100	M105	M110	M115	M120	M125	M130	M135	M140	M145	M150	M155	M160
	72	76	81	86	91	96	101	106	111	116	121	126	131	136	141	146	151	156
	4072	4536	5153	5809	6504	7238	8012	8825	9677	10568	11499	12469	13478	14527	15615	16742	17908	19113
	2036	2268	2577	2905	3252	3619	4006	4413	4839	5284	5750	6235	6739	7264	7808	8371	8954	9557
	1904	2127	2423	2737	3071	3425	3797	4189	4600	5030	5479	5948	6436	6943	7469	8015	8580	9163
	1904	2127	2423	2737	3071	3425	3797	4189	4600	5030	5479	5948	6436	6943	7469	8015	8580	9163
	M76	M80	M85	M90	M95	M100	M105	M110	M115	M120	M125	M130	M135	M140	M145	M150	M155	M160
	72	76	81	86	91	96	101	106	111	116	121	126	131	136	141	146	151	156
	4072	4536	5153	5809	6504	7238	8012	8825	9677	10568	11499	12469	13478	14527	15615	16742	17908	19113
	2125	2367	2689	3031	3393	3776	4180	4604	5049	5514	5999	6507	7032	7579	8147	8735	9343	9972
	2029	2266	2582	2917	3273	3650	4046	4464	4902	5360	5839	6339	6858	7399	7960	8541	9143	9765
	2029	2266	2582	2917	3273	3650	4046	4464	4902	5360	5839	6339	6858	7399	7960	8541	9143	9765
	M76	M80	M85	M90	M95	M100	M105	M110	M115	M120	M125	M130	M135	M140	M145	M150	M155	M160
	72	76	81	86	91	96	101	106	111	116	121	126	131	136	141	146	151	156
	4072	4536	5153	5809	6504	7238	8012	8825	9677	10568	11499	12469	13478	14527	15615	16742	17908	19113
	2932	3266	3710	4182	4683	5211	5769	6354	6967	7609	8279	8978	9704	10459	11243	12054	12894	13761
	2520	2815	3206	3623	4065	4533	5025	5544	6088	6658	7252	7873	8518	9189	9886	10608	11356	12128
	2520	2815	3206	3623	4065	4533	5025	5544	6088	6658	7252	7873	8518	9189	9886	10608	11356	12128
	M76	M80	M85	M90	M95	M100	M105	M110	M115	M120	M125	M130	M135	M140	M145	M150	M155	M160
	72	76	81	86	91	96	101	106	111	116	121	126	131	136	141	146	151	156
	4072	4536	5153	5809	6504	7238	8012	8825	9677	10568	11499	12469	13478	14527	15615	16742	17908	19113
	3187	3550	4033	4546	5090	5665	6270	6907	7573	8271	8999	9758	10548	11369	12220	13102	14015	14958
	2912	3253	3705	4187	4697	5238	5807	6407	7035	7693	8380	9097	9843	10619	11424	12258	13122	14015
	2912	3253	3705	4187	4697	5238	5807	6407	7035	7693	8380	9097	9843	10619	11424	12258	13122	14015

**Anchor components**

**For practical reasons, anchor bars should not be smaller than M39. It has proved worthwhile to form the threaded section by upsetting in order to prevent weakening this zone. The permissible stresses in the core of the threaded zone and thinner anchor shaft are therefore exploited to the full.**

It is not necessary to form the threaded section by upsetting when forming a rolled thread because rolling results in an outside thread diameter that is greater than the shaft diameter. Compared with an upset, machined thread, there are a number of advantages, e.g. higher strength and better accuracy of the profile, no interruptions to the fibres of the steel (dynamic loading capacity), see also EAU 2012.

And as longer threaded lengths are also possible, it is often unnecessary to include an additional turnbuckle. Loading tests on the Whitworth imperial thread still common these days have proved that this type of thread is the best one for rough building site conditions. Metric threads can also be used.

Fully killed steel grades to DIN EN 10025 should be chosen because these are not susceptible to ageing, brittle failure or stress corrosion cracking. Steel grades S 235 JR and S 355 J2 +N should be preferred. The higher grade, S 355 J2 +N, is normally specified for economic and safety reasons. The tables on pp. 10–15 provide an overview of the round steel tie rod sizes generally available.

Besides the usual round steel tie rods with threads at both ends, anchors with upset eyes or T-heads can be selected for certain types of connection.

Round steel tie rods can be provided with turnbuckles when there are no tensioning options at the ends (e.g. eye rods) or when it is not possible to fabricate them in one piece. Round steel tie rods are generally supplied in two pieces. The recommendation is to install the turnbuckle just behind the main wall. The anchor wall can be supported at an early date by backfilling with soil. In addition, good connection options are then available for later conversion measures.

Anchor rod with hexagonal nuts

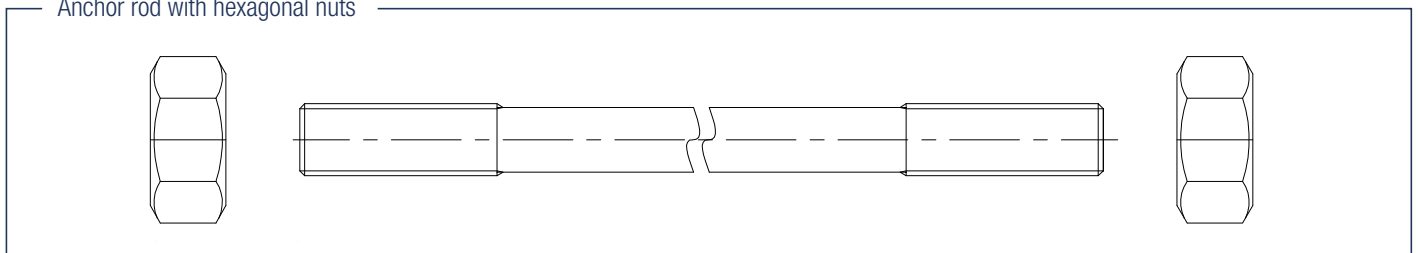

Eye rod

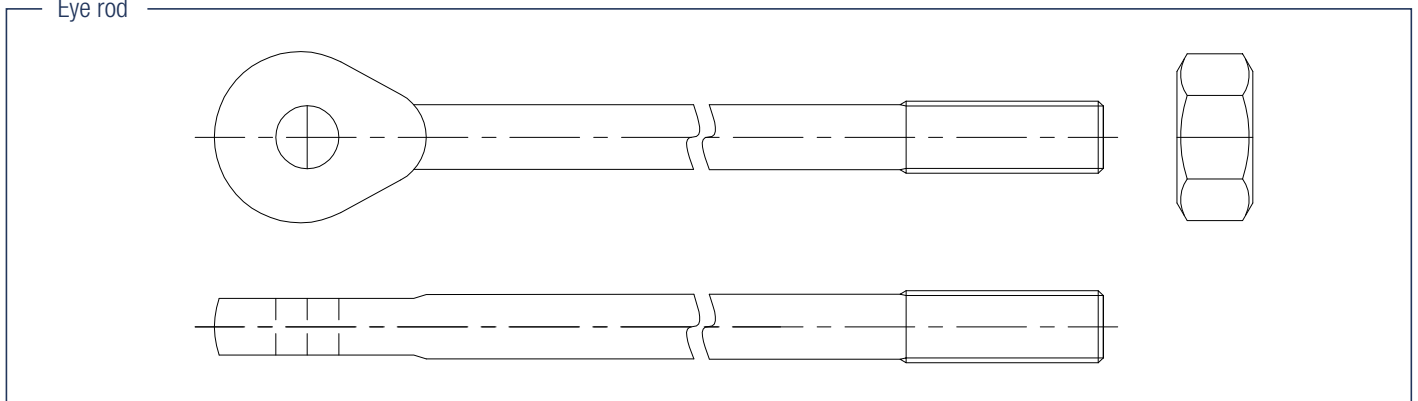

T-head rod

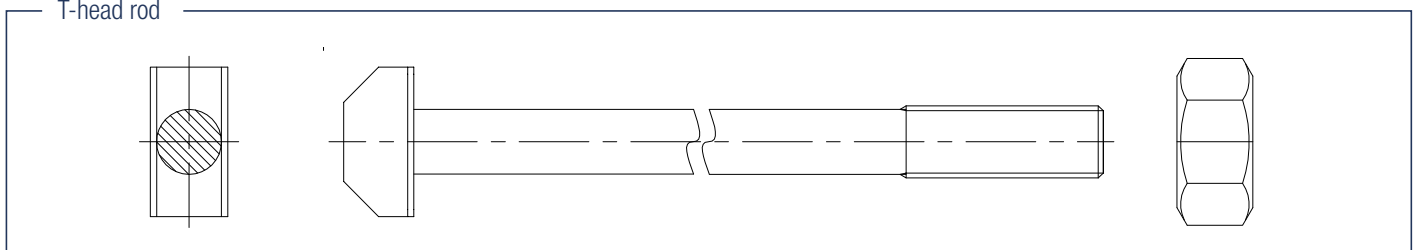



Turnbuckles have left- and right-hand threads for tensioning the anchorage and adjusting the total length of the anchor.

To ease transport and installation, the length of the rearward anchor rod should not exceed 20 m. If longer anchors are required, a coupler can be used to connect a further rod. Couplers have a continuous right-hand thread and therefore cannot be used for tensioning. Hinge turnbuckles are available for creating a joint that can serve to tension the rod as well as form an articulated connection.

Shackle joints can be used for special connections and when settlement is expected. In terms of articulation and installation, a design with upset eye rods, shackle joints and hinge pins is superior to the T-head form.

Universal joints should be provided where movement in both the vertical and the horizontal direction is required.

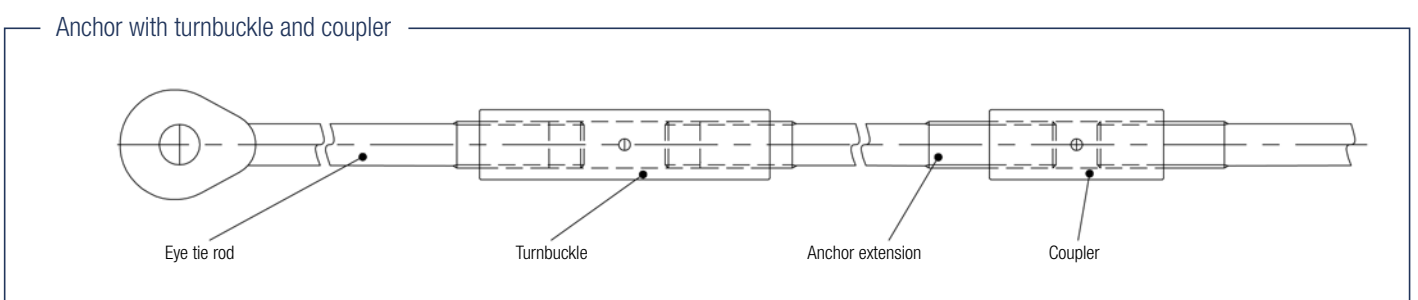
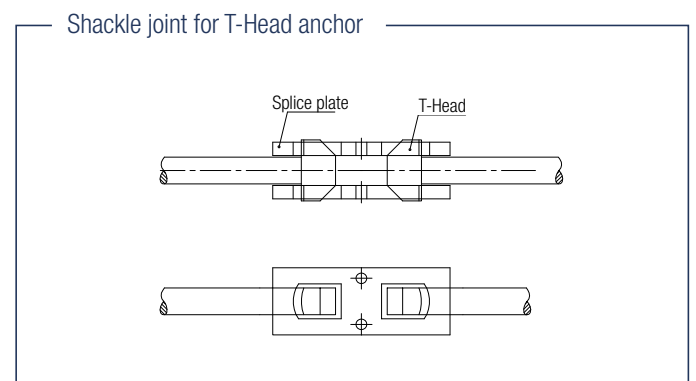
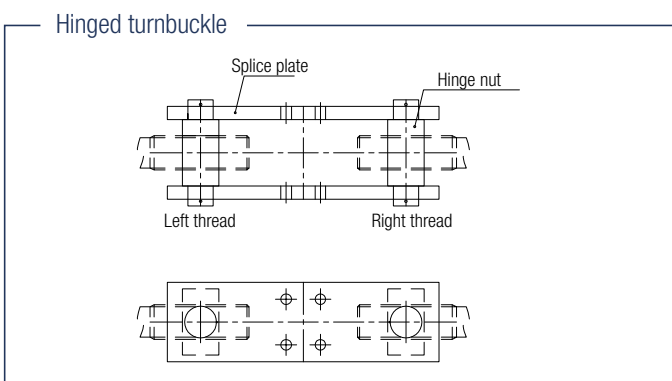
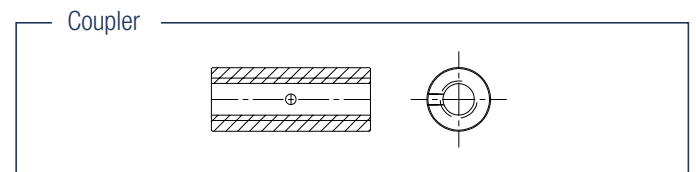
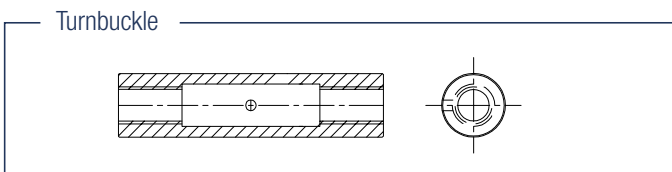

Turnbuckles for anchors



Anchor ASF355 to EAU with kt 0,55 and Anchor ASF355 with kt 0,6 in S355												
Nominal diameter	D1	Metric	M39	M42	M45	M48	M52	M56	M60	M64	M68	M72
Length	a	mm	350	400	400	450	450	450	500	500	500	500
Outside diameter	b	mm	63.5	70	73	76.1	82.5	82.5	88.9	101.6	101.6	108
Thread Length	c	mm	40	45	45	50	55	60	60	65	70	75
Undercut	e	mm	42	45	48	51	55	59	63	67	71	75
Hole diameter	f	mm	25	25	25	25	25	25	25	25	25	25
Weight		kg	5.4	7.7	8.1	9.7	11.4	10.2	13.3	19.2	17.6	20.0

Anchor ASF460/ASF500 to EAU with kt 0,55 / Anchor ASF460/ASF500 with kt 0,6 / Anchor ASF355 to ASF500 with kt 0,9 in 20MnV6												
Nominal diameter	D1	Metric	M39	M42	M45	M48	M52	M56	M60	M64	M68	M72
Length	a	mm	350	400	400	450	450	450	500	500	500	500
Outside diameter	b	mm	73	76.1	82.5	82.5	88.9	101.6	101.6	108	114.3	121
Thread Length	c	mm	40	45	45	50	55	60	60	65	70	75
Undercut	e	mm	42	45	48	51	55	59	63	67	71	75
Hole diameter	f	mm	25	25	25	25	25	25	25	25	25	25
Weight		kg	8.2	9.9	11.8	12.5	14.4	19.9	20.7	23.3	26.0	29.2

Anchor ASF720 with kt 0,6 in 20MnV6												
Nominal diameter	D1	Metric	M39	M42	M45	M48	M52	M56	M60	M64	M68	M72
Length	a	mm	350	400	400	450	450	450	500	500	500	500
Outside diameter	b	mm	70	73	76.1	82.5	88.9	101.6	101.6	108	114.3	121
Thread Length	c	mm	40	45	45	50	55	60	60	65	70	75
Undercut	e	mm	42	45	48	51	55	59	63	67	71	75
Hole diameter	f	mm	25	25	25	25	25	25	25	25	25	25
Weight		kg	7.3	8.8	9.3	12.5	14.4	19.9	20.7	23.3	26.0	29.2

Anchor ASF720 with kt 0,9 in 20MnV6												
Nominal diameter	D1	metric	M39	M42	M45	M48	M52	M56	M60	M64	M68	M72
Length	a	mm	350	400	400	450	450	450	500	500	500	500
Outside diameter	b	mm	82.5	82.5	88.9	88.9	101.6	101.6	108	114.3	121	127
Thread Length	c	mm	40	45	45	50	55	60	60	65	70	75
Undercut	e	mm	42	45	48	51	55	59	63	67	71	75
Hole diameter	f	mm	20	20	20	20	20	20	20	20	20	20
Weight		kg	11.4	12.4	14.5	15.5	21.1	19.9	24.9	27.6	30.9	33.7

# 3

## ANCHOR CONNECTION ELEMENTS

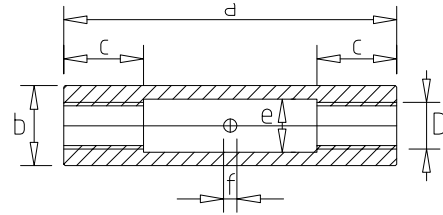
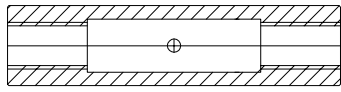

	M76	M80	M85	M90	M95	M100	M105	M110	M115	M120	M125	M130	M135	M140	M145	M150	M155	M160
	550	550	550	550	550	550	550	550	550	550	550	550	550	550	550	550	550	550
	114.3	114.3	121	127	133	139.7	152.4	152.4	159	165.1	177.8	177.8	191	193.7	203	216	216	219.1
	80	80	85	90	95	100	105	110	115	120	125	130	135	140	145	150	155	160
	79	83	88	93	98	103	108	113	118	123	128	133	138	143	148	153	158	163
	25	25	25	25	25	25	25	25	25	25	25	25	25	25	25	25	25	25
	24.7	22.6	25.1	27.2	29.4	32.3	41.4	37.7	40.9	43.6	54.2	49.9	61.9	60.8	68.4	81.9	76.7	76.0

	M76	M80	M85	M90	M95	M100	M105	M110	M115	M120	M125	M130	M135	M140	M145	M150	M155	M160
	550	550	550	550	550	550	550	550	550	550	550	550	550	550	550	550	550	550
	127	133	139.7	141.3	152.4	159	168.3	177.8	191	193.7	203	203	219.1	219.1	229	229	244.5	244.5
	80	80	85	90	95	100	105	110	115	120	125	130	135	140	145	150	155	160
	79	83	88	93	98	103	108	113	118	123	128	133	138	143	148	153	158	163
	25	25	25	25	25	25	25	25	25	25	25	25	25	25	25	25	25	25
	35.1	38.3	41.7	40.2	48.2	51.8	58.7	66.2	78.9	78.4	86.8	82.4	101.0	96.3	106.5	101.5	121.2	115.9

	M76	M80	M85	M90	M95	M100	M105	M110	M115	M120	M125	M130	M135	M140	M145	M150	M155	M160
	550	550	550	550	550	550	550	550	550	550	550	550	550	550	550	550	550	550
	127	133	139.7	141.3	152.4	159	168.3	177.8	191	193.7	203	203	219.1	219.1	229	229	244.5	244.5
	80	80	85	90	95	100	105	110	115	120	125	130	135	140	145	150	155	160
	79	83	88	93	98	103	108	113	118	123	128	133	138	143	148	153	158	163
	25	25	25	25	25	25	25	25	25	25	25	25	25	25	25	25	25	25
	35.1	38.3	41.7	40.2	48.2	51.8	58.7	66.2	78.9	78.4	86.8	82.4	101.0	96.3	106.5	101.5	121.2	115.9

	M76	M80	M85	M90	M95	M100	M105	M110	M115	M120	M125	M130	M135	M140	M145	M150	M155	M160
	550	550	550	550	550	550	550	550	550	550	550	550	550	550	550	550	550	550
	133	139.7	152.4	159	165.1	168.3	177.8	191	193.7	203	216	219.1	229	244.5	244.5	273	273	273
	80	80	85	90	95	100	105	110	115	120	125	130	135	140	145	150	155	160
	79	83	88	93	98	103	108	113	118	123	128	133	138	143	148	153	158	163
	20	20	20	20	20	25	25	25	25	25	25	25	25	25	25	25	25	25
	40.4	44.5	54.3	58.3	61.8	62.1	69.8	82.7	82.4	90.9	105.2	105.5	116.0	136.2	131.4	176.4	171.3	165.9

Couplers for anchors



Anchor ASF355 to EAU with kt 0,55 and Anchor ASF355 with kt 0,6 in S355												
Nominal diameter	D1	Metric	M39	M42	M45	M48	M52	M56	M60	M64	M68	M72
Length	a	mm	120	130	140	150	150	170	180	180	190	200
Outside diameter	b	mm	63.5	70	73	76.1	82.5	82.5	88.9	101.6	101.6	108
Hole diameter	f	mm	25	25	25	25	25	25	25	25	25	25
Weight		kg	1.9	2.5	2.9	3.2	3.8	3.8	4.8	6.9	6.7	8.0

Anchor ASF460/ASF500 to EAU with kt 0,55 / Anchor ASF460/ASF500 with kt 0,6 / Anchor ASF355 to ASF500 with kt 0,9 in 20MnV6												
Nominal diameter	D1	Metric	M39	M42	M45	M48	M52	M56	M60	M64	M68	M72
Length	a	mm	120	130	140	150	150	170	180	180	190	200
Outside diameter	b	mm	73	76.1	82.5	82.5	88.9	101.6	101.6	108	114.3	121
Hole diameter	f	mm	25	25	25	25	25	25	25	25	25	25
Weight		kg	2.8	3.2	4.1	4.2	4.8	7.5	7.5	8.4	9.9	11.7

Anchor ASF720 with kt 0,6 in 20MnV6												
Nominal diameter	D1	Metric	M39	M42	M45	M48	M52	M56	M60	M64	M68	M72
Length	a	mm	120	130	140	150	150	170	180	180	190	200
Outside diameter	b	mm	70	73	76.1	82.5	88.9	101.6	101.6	108	114.3	121
Hole diameter	f	mm	25	25	25	25	25	25	25	25	25	25
Weight		kg	2.5	2.9	3.3	4.2	4.8	7.5	7.5	8.4	9.9	11.7

Anchor ASF720 with kt 0,9 in 20MnV6												
Nominal diameter	D1	Metric	M39	M42	M45	M48	M52	M56	M60	M64	M68	M72
Length	a	mm	120	130	140	150	150	170	180	180	190	200
Outside diameter	b	mm	82.5	82.5	88.9	88.9	101.6	101.6	108	114.3	121	127
Hole diameter	f	mm	20	20	20	20	20	20	20	20	20	20
Weight		kg	3.9	4.0	5.1	5.2	7.0	7.5	8.9	10.0	11.7	13.5

# 3

## ANCHOR CONNECTION ELEMENTS

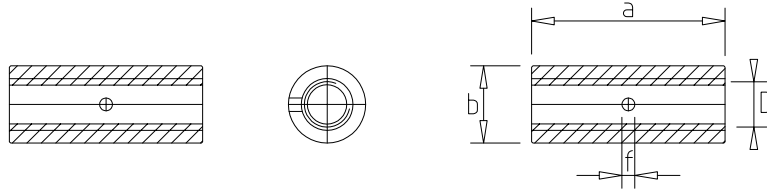

	M76	M80	M85	M90	M95	M100	M105	M110	M115	M120	M125	M130	M135	M140	M145	M150	M155	M160
	210	225	240	250	260	260	260	260	260	260	260	260	270	280	290	300	310	320
	114.3	114.3	121	127	133	139.7	152.4	152.4	159	165.1	177.8	177.8	191	193.7	203	216	216	219.1
	25	25	25	25	25	25	25	25	25	25	25	25	25	25	25	25	25	25
	9.4	9.2	11.0	12.4	13.9	15.3	19.6	17.8	19.3	20.6	25.6	23.6	30.4	30.9	36.1	44.7	43.3	44.2

	M76	M80	M85	M90	M95	M100	M105	M110	M115	M120	M125	M130	M135	M140	M145	M150	M155	M160
	210	225	240	250	260	275	285	295	305	320	330	340	350	360	370	380	390	400
	127	133	139.7	141.3	152.4	159	168.3	177.8	191	193.7	203	203	219.1	219.1	229	229	244.5	244.5
	25	25	25	25	25	25	25	25	25	25	25	25	25	25	25	25	25	25
	13.4	15.7	18.2	18.3	22.8	25.9	30.4	35.5	43.7	45.6	52.1	51.0	64.3	63.0	71.7	70.1	86.0	84.3

	M76	M80	M85	M90	M95	M100	M105	M110	M115	M120	M125	M130	M135	M140	M145	M150	M155	M160
	210	225	240	250	260	275	285	295	305	320	330	340	350	360	370	380	390	400
	127	133	139.7	141.3	152.4	159	168.3	177.8	191	193.7	203	203	219.1	219.1	229	229	244.5	244.5
	25	25	25	25	25	25	25	25	25	25	25	25	25	25	25	25	25	25
	13.4	15.7	18.2	18.3	22.8	25.9	30.4	35.5	43.7	45.6	52.1	51.0	64.3	63.0	71.7	70.1	86.0	84.3

	M76	M80	M85	M90	M95	M100	M105	M110	M115	M120	M125	M130	M135	M140	M145	M150	M155	M160
	210	225	240	250	260	275	285	295	305	320	330	340	350	360	370	380	390	400
	133	139.7	152.4	159	165.1	168.3	177.8	191	193.7	203	216	219.1	229	244.5	244.5	273	273	273
	20	20	20	20	20	25	25	25	25	25	25	25	25	25	25	25	25	25
	15.4	18.2	23.7	26.5	29.2	31.1	36.2	44.3	45.7	52.9	63.1	65.2	73.8	89.2	88.4	121.9	121.4	120.7

Hinged turnbuckles for anchors



Anchor ASF355 to EAU with kt 0,55 and Anchor ASF355 with kt 0,6 in S355												
Nominal diameter	D1	Metric	M39	M42	M45	M48	M52	M56	M60	M64	M68	M72
Length (plate)	a	mm	510	530	540	545	555	570	615	630	640	650
Height (plate)	b	mm	90	90	100	110	110	130	130	140	150	160
Thickness (plate)	c	mm	15	15	20	20	20	20	25	25	25	25
Hole spacing (plate)	e	mm	400	410	410	410	410	410	450	450	450	450
Height (nut)	f	mm	40	45	45	50	55	60	60	65	70	75
Width (nut between plates)	g	mm	60	65	70	75	80	85	90	95	100	105
Width (nut + plates)	h	mm	100	110	120	130	130	140	150	160	160	170

Anchor ASF460/ASF500 to EAU with kt 0,55 / Anchor ASF460/ASF500 with kt 0,6 / Anchor ASF355 to ASF500 with kt 0,9 in S355												
Nominal diameter	D1	Metric	M39	M42	M45	M48	M52	M56	M60	M64	M68	M72
Length (plate)	a	mm	530	545	560	570	580	595	645	655	670	685
Height (plate)	b	mm	100	110	120	130	130	150	150	160	170	180
Thickness (plate)	c	mm	20	20	25	25	25	30	30	35	35	35
Hole spacing (plate)	e	mm	400	410	410	410	410	410	450	450	450	450
Height (nut)	f	mm	40	45	45	50	55	60	60	65	70	75
Width (nut between plates)	g	mm	60	65	70	75	80	85	90	95	100	105
Width (nut + plates)	h	mm	110	120	130	140	140	160	160	180	180	190

Anchor ASF720 with kt 0,6 in S355												
Nominal diameter	D1	Metric	M39	M42	M45	M48	M52	M56	M60	M64	M68	M72
Length (plate)	a	mm	530	545	560	570	580	595	645	655	670	685
Height (plate)	b	mm	100	110	120	130	130	150	150	160	170	180
Thickness (plate)	c	mm	20	20	20	25	25	25	30	30	35	35
Hole spacing (plate)	e	mm	400	410	410	410	410	410	450	450	450	450
Height (nut)	f	mm	40	45	45	50	55	60	60	65	70	75
Width (nut between plates)	g	mm	60	65	70	75	80	85	90	95	100	105
Width (nut + plates)	h	mm	110	120	120	140	140	150	160	170	180	190

Anchor ASF720 with kt 0,9 in S355												
Nominal diameter	D1	Metric	M39	M42	M45	M48	M52	M56	M60	M64	M68	M72
Length (plate)	a	mm	530	55	560	570	580	595	645	655	670	685
Height (plate)	b	mm	100	110	120	130	130	150	150	160	170	180
Thickness (plate)	c	mm	25	25	25	30	30	35	35	35	40	40
Hole spacing (plate)	e	mm	400	410	410	410	410	410	450	450	450	450
Height (nut)	f	mm	40	45	45	50	55	60	60	65	70	75
Width (nut between plates)	g	mm	60	65	70	75	80	85	90	95	100	105
Width (nut + plates)	h	mm	120	130	130	150	150	170	170	180	190	200

# 3

## ANCHOR CONNECTION ELEMENTS

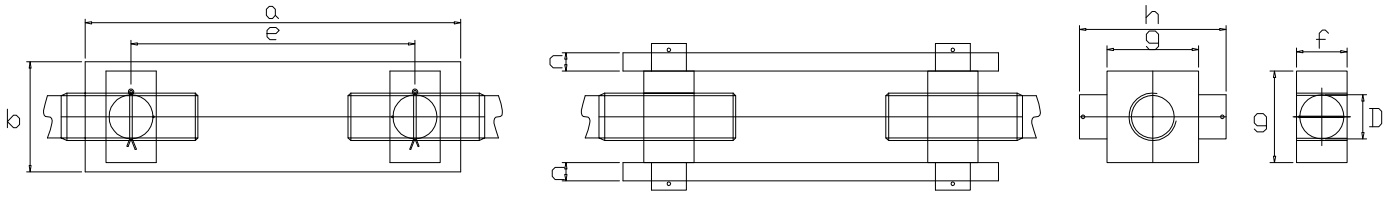

	M76	M80	M85	M90	M95	M100	M105	M110	M115	M120	M125	M130	M135	M140	M145	M150	M155	M160
	765	775	790	840	860	865	875	880	880	900	900	915	935	945	960	975	990	1005
	170	180	190	200	210	220	230	240	250	270	280	290	300	310	320	330	350	360
	30	30	30	35	35	40	40	40	40	45	45	50	50	50	55	55	60	60
	550	550	550	590	590	580	580	570	560	560	550	550	550	550	550	550	550	550
	80	80	85	90	95	100	105	110	115	120	125	130	135	140	145	150	155	160
	110	115	120	130	135	145	150	155	165	170	180	185	190	200	210	210	220	230
	180	190	190	210	220	240	240	250	260	270	280	300	300	310	330	330	350	360

	M76	M80	M85	M90	M95	M100	M105	M110	M115	M120	M125	M130	M135	M140	M145	M150	M155	M160
	795	810	860	880	900	910	925	930	935	955	960	980	995	1010	1025	1045	1060	1080
	190	200	240	230	240	260	270	280	290	310	320	340	350	360	370	390	400	420
	40	40	45	45	50	55	55	60	60	65	65	70	70	75	75	80	80	85
	550	550	550	590	590	580	580	570	560	560	550	550	550	550	550	550	550	550
	80	80	85	90	95	100	105	110	115	120	125	130	135	140	145	150	155	160
	110	115	120	130	135	145	150	155	165	170	180	185	190	200	210	210	220	230
	200	210	220	230	250	270	270	290	300	310	320	340	340	360	370	380	390	410

	M76	M80	M85	M90	M95	M100	M105	M110	M115	M120	M125	M130	M135	M140	M145	M150	M155	M160
	795	810	830	880	900	910	925	930	935	955	960	980	995	1010	1025	1045	1060	1080
	190	200	220	230	240	260	270	280	290	310	320	340	350	360	370	390	400	420
	35	40	40	45	45	50	50	55	55	60	60	65	65	70	70	75	75	80
	550	550	550	590	590	580	580	570	560	560	550	550	550	550	550	550	550	550
	80	80	85	90	95	100	105	110	115	120	125	130	135	140	145	150	155	160
	110	115	120	130	135	145	150	155	165	170	180	185	190	200	210	210	220	230
	190	210	210	230	240	260	260	280	290	300	310	330	330	350	360	370	380	400

	M76	M80	M85	M90	M95	M100	M105	M110	M115	M120	M125	M130	M135	M140	M145	M150	M155	M160
	795	810	830	885	900	910	925	930	935	955	960	980	995	1015	1035	1050	1070	1085
	190	210	220	230	240	260	270	280	300	310	320	340	350	360	380	390	410	420
	45	50	50	55	55	60	65	65	70	70	75	80	80	85	90	95	95	100
	550	550	550	590	590	580	580	570	560	560	550	550	550	550	550	550	550	550
	80	80	85	90	95	100	105	110	115	120	125	130	135	140	145	150	155	160
	110	115	120	130	135	145	150	155	165	170	180	185	190	200	210	210	220	230
	210	230	230	250	260	280	290	300	320	320	340	360	360	380	400	410	420	440

The connection between the anchor and the main wall can be positioned in the trough of the sheet pile, either at the front, on the sheet pile wall itself, or at the rear, on the waling (tension waling). The spacing of the anchors is then governed by the system width of the sheet pile wall.

End plates are necessary and we distinguish between front plates on the main wall for U- and Z-sections, and plates for the connection between the waling and the main or anchor wall, with or without additional (threaded) rocker plates.

To improve the load transfer, the front plates at the main wall should generally cover approx. 80% of the width of the trough of the sheet pile. A tapered plate can be used in addition to the end plate to compensate for the angle of a raking anchor.

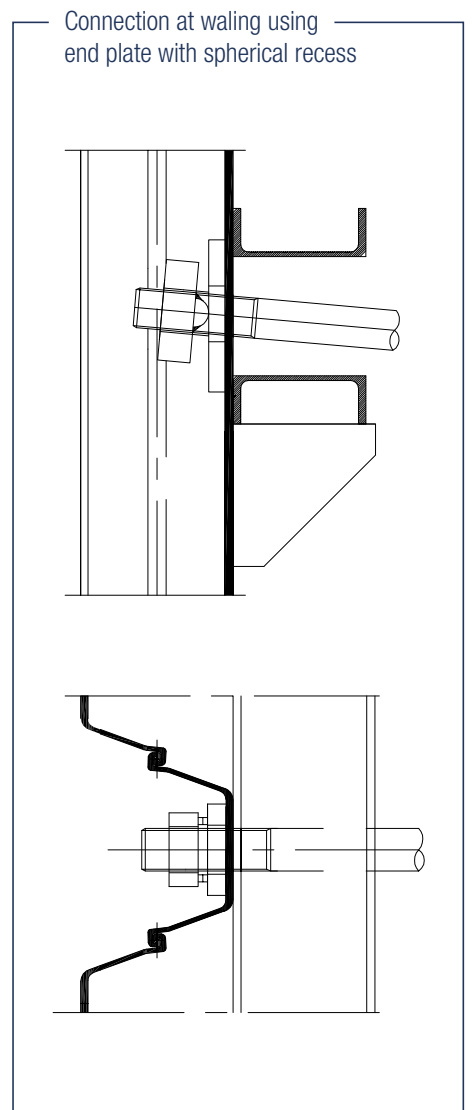
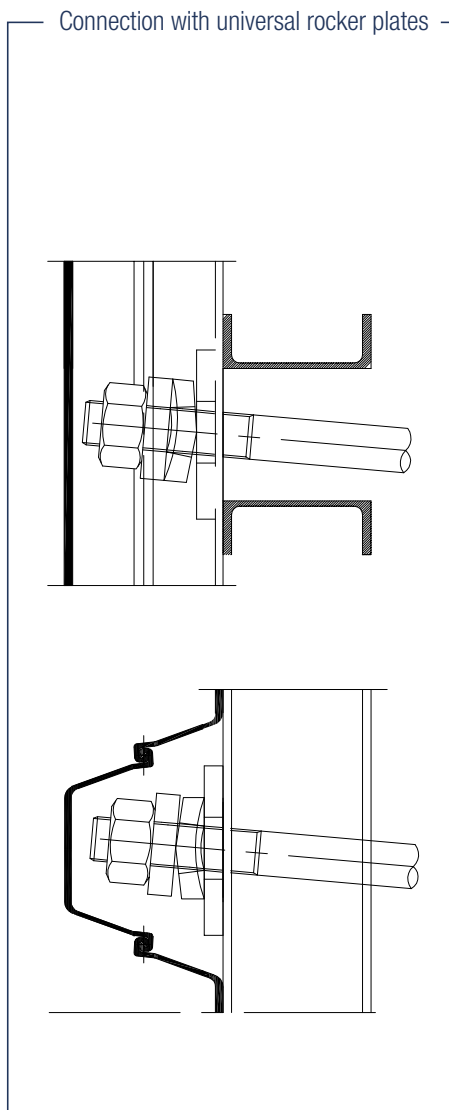
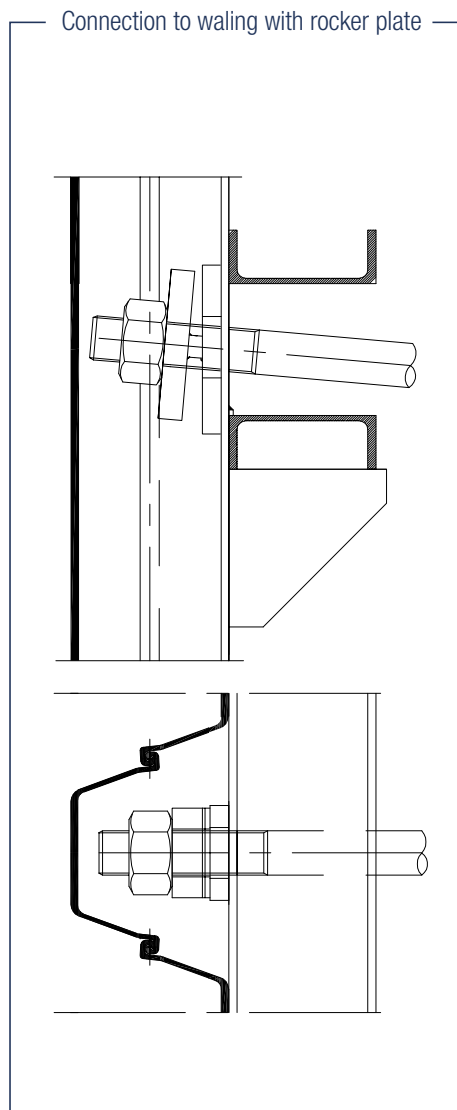
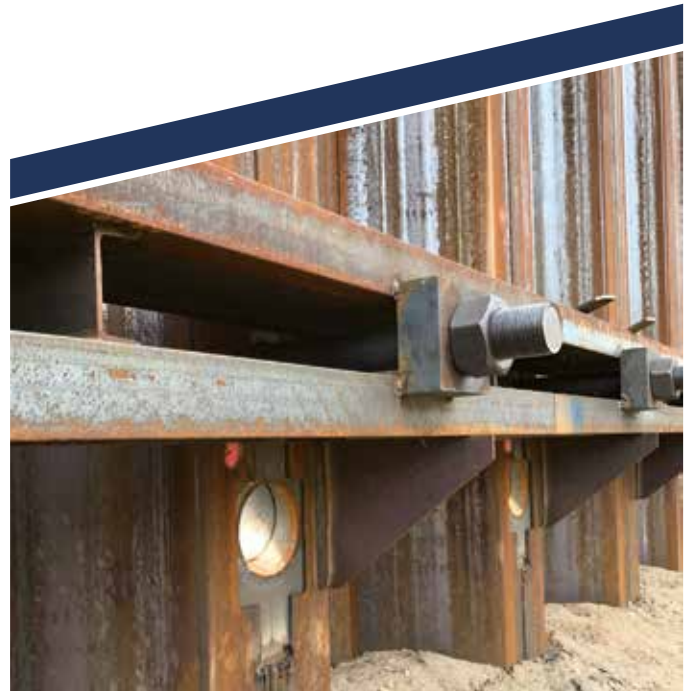

**When settlement is expected, the anchor connection should be hinged and allow movement in the vertical direction in order to avoid the associated bending stresses at the threaded joints. To allow movement, a rocker plate, end plate with spherical recess or threaded rocker plate is normally used.**

A rocker plate has a semicircular roller that allows the anchor to rotate, and when subjected to moments, stresses close to the yield stress occur, which permit angular rotation without any particular resistance. Rotation with a threaded rocker plate is possible thanks to the semicircular roller welded to the plate.

If horizontal movements are expected as well, two opposed hinges can be arranged one behind the other, or a universal rocker plate or end plate with spherical recess can be used. A hinge effect can also be achieved by using an anchor with a rounded T-head. Where the depth of the wall is limited, a threaded rocker plate can be used to save the depth of the nut.

For anchors at steep angles or where excessive settlement or rotational movements are expected, the recommendation is to position the anchor connection in the trough of the sheet pile wall but below the waling. Again, various details are possible here depending on the particular requirements.

The connection to combined sheet piling with tubular piles is generally achieved via T-connections that pass through the wall of the pile. These are introduced into the tubular pile from above.

At the anchor wall, the anchor is connected via the waling, which is fitted to the outside here (compression waling). A simple connection with end plate only is common.

A hinged connection is necessary, for example, when the anchor is laid in filled ground over its entire length and settlement is likely.



## Hexagonal nuts

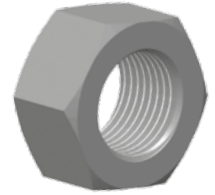

ASF355 to ASF500 / ASF600 to ASF900 in class 10			M39	M42	M45	M48	M52	M56	M60	M64	M68	M72
Nominal diameter	ØD1	Metric										
Width across flats	s	mm	60	65	70	75	80	85	90	95	100	105
Width across corners	a	mm	66	72	78	83	89	94	100	106	112	117
Height	m	mm	31	34	36	38	42	45	48	51	54	58
Weight		kg	0.5	0.7	0.8	1	1.2	1.4	1.7	2	2.3	2.6

## Calotte nuts

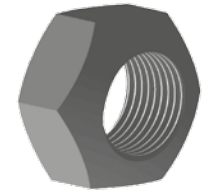

ASF355 to ASF500 / ASF600 to ASF900 in class 10			M39	M42	M45	M48	M52	M56	M60	M64	M68	M72
Nominal diameter	ØD1	Metric										
Width across flats	s	mm	60	65	70	75	80	85	90	95	100	105
Width across corners	a	mm	66	72	78	83	89	94	100	106	112	117
Height	m	mm	31	34	36	38	42	45	48	51	54	58
Weight		kg	0.5	0.7	0.8	1	1.2	1.4	1.7	2	2.3	2.6

## Rocker plate for anchor



Anchor ASF355 to EAU with kt 0,55 and Anchor ASF355 with kt 0,6 in S355			M39	M42	M45	M48	M52	M56	M60	M64	M68	M72
Nominal diameter	ØD1	Metric										
Plate width	b	mm	80	90	90	100	100	110	120	120	130	140
Plate height	h	mm	70	80	80	90	90	100	110	110	120	120
Plate thickness	t	mm	20	30	30	30	30	30	40	40	40	40
Rocker	s	mm	50	50	50	50	50	50	50	50	50	50
Weight		kg	1.1	1.8	1.8	2.2	2.0	2.5	3.8	3.7	4.4	4.5

## Threaded rocker plate for anchor



Anchor ASF355 to EAU with kt 0,55 and Anchor ASF355 with kt 0,6 in S355			M39	M42	M45	M48	M52	M56	M60	M64	M68	M72
Nominal diameter	ØD1	Metric										
Plate width	b	mm	100	110	110	120	130	150	150	150	160	160
Plate height	h	mm	100	110	110	120	130	150	150	150	160	160
Plate thickness	t	mm	35	40	40	45	45	50	55	60	65	65
Rocker	s	mm	50	50	50	50	50	50	50	50	50	50
Weight		kg	2.9	3.9	3.8	5.0	5.8	8.6	9.2	9.7	11.9	11.7

# 4

## ANCHOR/WALING JOINTS

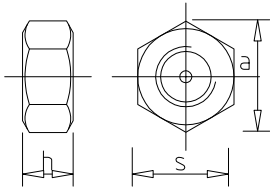

	M76	M80	M85	M90	M95	M100	M105	M110	M115	M120	M125	M130	M135	M140	M145	M150	M155	M160
	110	115	120	130	135	145	150	155	165	170	180	185	190	200	210	210	220	230
	123	128	134	145	151	162	168	173	185	190	202	207	212	224	235	235	245	255
	61	64	68	72	76	80	84	88	92	96	100	104	108	112	116	120	124	128
	3	3.4	3.9	4.9	5.6	6.8	7.5	8.2	10.1	11.7	13	13.8	15.2	17.5	20.7	20	23.1	26.5

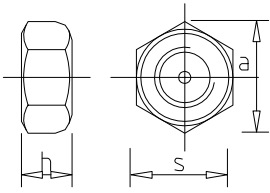

	M76	M80	M85	M90	M95	M100	M105	M110	M115	M120	M125	M130	M135	M140	M145	M150	M155	M160
	110	115	120	130	135	145	150	155	165	170	180	185	190	200	210	210	220	230
	123	128	134	145	151	162	168	173	185	190	202	207	212	224	235	235	245	255
	61	64	68	72	76	80	84	88	92	96	100	104	108	112	116	120	124	128
	3	3.4	3.9	4.9	5.6	6.8	7.5	8.2	10.1	11.7	13	13.8	15.2	17.5	20.7	20	23.1	26.5

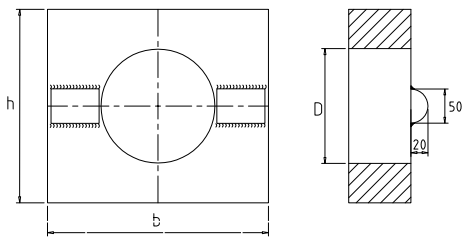

	M76	M80	M85	M90	M95	M100	M105	M110	M115	M120	M125	M130	M135	M140	M145	M150	M155	M160
	140	150	160	180	180	190	200	210	220	230	240	250	260	270	280	290	300	310
	130	130	140	150	150	160	170	180	190	190	200	210	220	230	240	240	250	250
	40	40	50	50	50	50	60	60	60	60	70	70	70	70	80	80	90	90
	50	60	60	60	60	60	60	60	60	60	60	60	60	60	60	60	60	60
	4.9	5.4	7.8	9.6	9.2	10.3	14.0	15.5	17.1	17.2	21.7	23.7	25.8	28.6	34.4	35.3	42.5	43.5

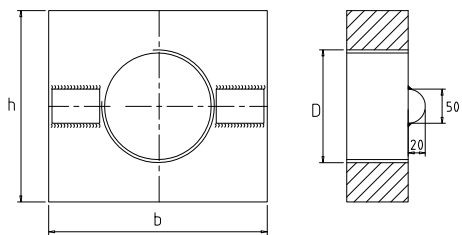

	M76	M80	M85	M90	M95	M100	M105	M110	M115	M120	M125	M130	M135	M140	M145	M150	M155	M160
	180	180	180	200	200	220	220	220	230	240	250	260	280	280	300	300	320	320
	180	180	180	200	200	220	220	220	230	240	250	260	280	280	300	300	320	320
	70	80	80	85	95	100	105	110	115	120	130	140	150	150	150	150	160	160
	50	60	60	60	60	60	60	60	60	60	60	60	60	60	60	60	60	60
	16.1	18.3	17.8	23.7	25.7	33.2	34.0	34.8	39.7	44.9	52.6	61.1	77.1	75.7	88.3	86.8	106.7	105.1

Anchor ball joints

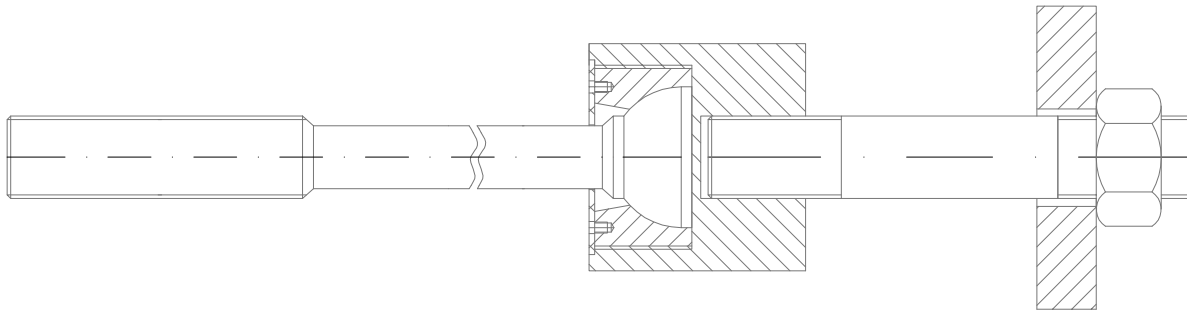

Anchor ASF355 to ASF500 to 1993-5 with kt 0,9		
Nominal diameter (anchor)	ØD	(mm)
Height (casing) in 42CrMo4V	e	(mm)
Width (casing) in 42CrMo4V	g	(mm)
Nominal diameter (bolt) in grade 10.9	Øc	(mm)
Height + Width (plate) in S355	hp, wp	(mm)
Thickness (plate) in S355	tp	(mm)

M39	M42	M45	M48	M52	M56	M60	M64	M68	M72
110	120	125	135	145	155	170	180	190	205
70	75	80	85	95	100	110	115	120	130
M33	M36	M39	M42	M45	M48	M52	M56	M60	M64
140	140	160	160	180	180	180	200	200	200
30	35	35	40	40	40	40	45	45	45

Anchor ASF720 to 1993-5 with kt 0,9		
Nominal diameter (anchor)	ØD	(mm)
Height (casing) in 42CrMo4V	e	(mm)
Width (casing) in 42CrMo4V	g	(mm)
Nominal diameter (bolt) in grade 10.9	Øc	(mm)
Height + Width (plate) in S355	hp, wp	(mm)
Thickness (plate) in S355	tp	(mm)

M39	M42	M45	M48	M52	M56	M60	M64	M68	M72
110	120	125	135	145	155	170	180	190	205
80	85	90	95	105	110	120	130	135	145
M36	M39	M42	M45	M48	M52	M56	M60	M64	M68
140	160	160	180	180	180	200	200	200	220
45	35	35	45	45	45	50	50	50	50

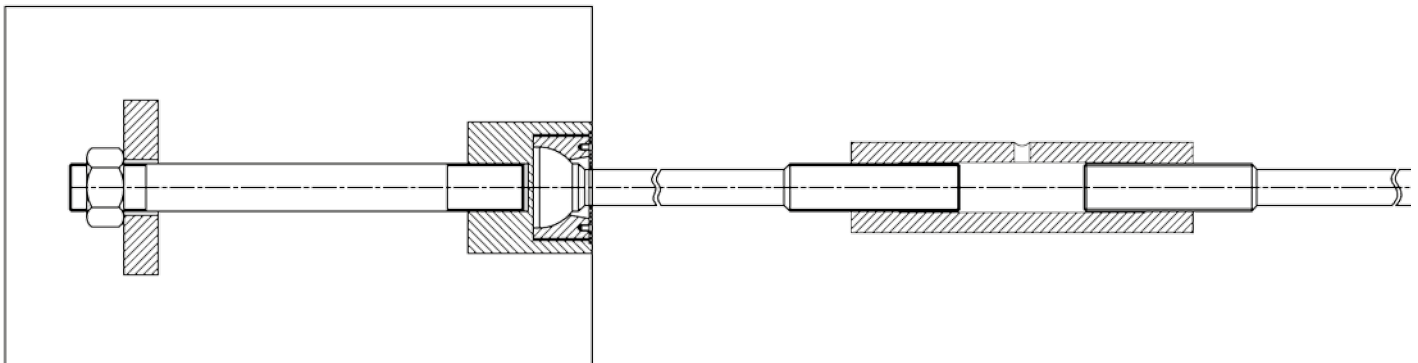

# 4

## ANCHOR/WALING JOINTS

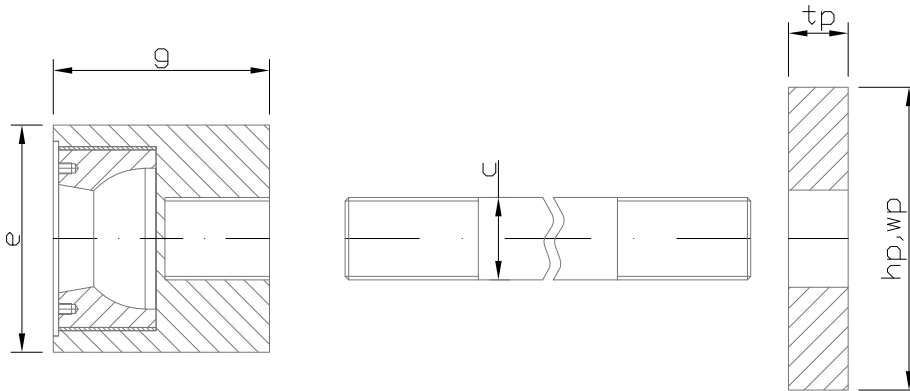

	M76	M80	M85	M90	M95	M100	M105	M110	M115	M120	M125	M130	M135	M140	M145	M150	M155	M160
	210	225	240	250	265	280	295	310	320	335	350	365	380	390	405	420	435	450
	135	145	155	170	180	185	195	205	215	225	230	240	250	260	270	280	290	300
	M68	M72	M76	M80	M85	M90	M95	M100	M105	M110	M115	M120	M125	M130	M135	M140	M145	M150
	220	220	240	240	240	260	280	280	280	280	300	320	340	340	340	360	360	380
	50	50	50	60	65	65	65	65	70	70	70	75	75	80	80	85	90	90

	M76	M80	M85	M90	M95	M100	M105	M110	M115	M120	M125	M130	M135	M140	M145	M150	M155	M160
	210	225	240	250	265	280	295	310	320	335	350	365	380	390	405	420	435	450
	150	160	170	180	190	200	210	220	230	240	250	260	270	280	290	300	310	320
	M72	M76	M80	M85	M90	M95	M100	M105	M110	M115	M120	M125	M130	M135	M140	M145	M150	M155
	220	240	240	240	260	280	280	280	280	300	320	340	340	340	360	360	380	380
	50	50	60	65	65	70	70	80	80	80	85	85	95	95	95	100	100	105

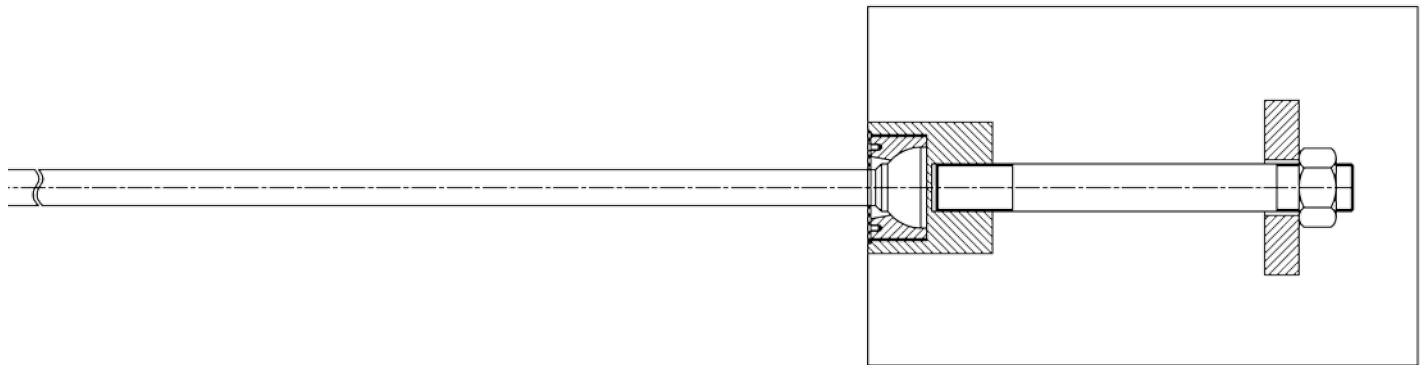

**Rear plates for Anchor ASF355**

to 1993-5 with kt 0,9 in S355



**Typ I – angle 0°**

Nominal diameter	ØD	(mm)	M39	M42	M45	M48	M52	M56	M60	M64	M68	M72	M76	M80
<b>Waling</b>			UNP180	UNP200	UNP200	UNP220	UNP240	UNP240	UNP260	UNP280	UNP300	UNP320	UNP320	UNP350
Waling spacing			80	80	80	80	80	80	100	100	100	100	100	100
Width	wp	(mm)	160	160	180	180	180	200	200	200	220	220	240	240
Height	hp	(mm)	140	140	140	140	140	140	160	160	160	160	160	160
Thickness	tp	(mm)	20	25	25	25	25	30	30	30	30	30	30	35
Drilling	Ød	(mm)	45.0	48.0	51.0	54.0	58.0	62.0	66.0	70.0	74.0	78.0	82.0	86.0



**Typ III – angle up to max. 5°**

Nominal diameter	ØD	(mm)	M39	M42	M45	M48	M52	M56	M60	M64	M68	M72	M76	M80
<b>Waling</b>			UNP180	UNP200	UNP200	UNP220	UNP240	UNP240	UNP260	UNP280	UNP300	UNP320	UNP320	UNP350
Waling spacing			100	100	120	120	120	140	140	140	160	160	180	180
Width	wp	(mm)	160	160	180	180	180	200	200	200	220	220	240	240
Height	hp	(mm)	160	160	180	180	180	200	200	200	220	220	240	240
Thickness	tp	(mm)	20	20	25	25	25	30	35	35	40	40	45	45
Drilling	Ød	(mm)	45.0	48.0	51.0	54.0	58.0	62.0	67.0	71.0	76.0	80.0	84.0	89.0



**Typ II – angle up to max. 10°**

Nominal diameter	ØD	(mm)	M39	M42	M45	M48	M52	M56	M60	M64	M68	M72	M76	M80
<b>Waling</b>			UNP180	UNP200	UNP200	UNP220	UNP240	UNP240	UNP260	UNP280	UNP300	UNP320	UNP320	UNP350
Waling spacing			100	100	120	120	120	140	140	160	160	180	180	180
Width	wp	(mm)	160	160	180	180	180	200	200	200	220	220	240	240
Height	hp	(mm)	160	160	180	180	180	200	200	220	220	240	240	240
Thickness	tp	(mm)	20	25	25	25	25	30	35	40	40	45	45	45
Drilling	Ød	(mm)	48.0	51.0	55.0	59.0	64.0	68.0	73.0	78.0	83.0	88.0	93.0	98.0

# 4

## ANCHOR/WALING JOINTS

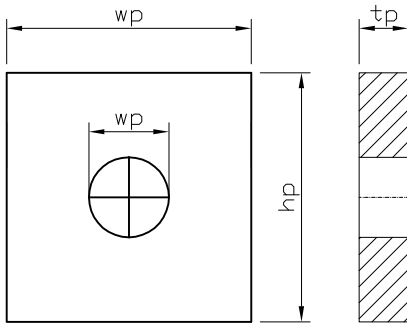

	M85	M90	M95	M100	M105	M110	M115	M120	M125	M130	M135	M140	M145	M150	M155	M160
	UNP380	UNP400	UNP400	HEB340	HEB360	HEB400	HEB450	HEB450	HEB500	HEB550	HEB550	HEB600	HEB600	HEB650	HEB650	HEB700
	120	120	120	140	140	140	140	140	160	160	160	160	180	180	180	180
	240	260	280	280	280	280	300	320	340	340	340	360	360	380	380	400
	180	180	180	200	200	200	200	200	220	220	220	220	240	240	240	240
	40	40	45	45	45	45	45	50	50	55	55	55	60	60	65	65
	91.0	96.0	101.0	106.0	111.0	116.0	121.0	126.0	131.0	136.0	141.0	146.0	151.0	156.0	161.0	166.0

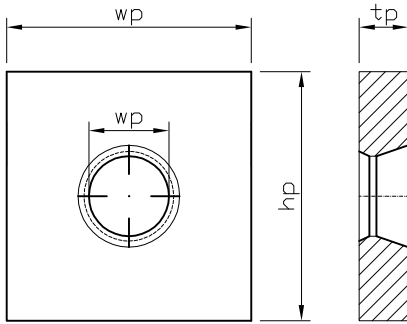

	M85	M90	M95	M100	M105	M110	M115	M120	M125	M130	M135	M140	M145	M150	M155	M160
	UNP380	UNP400	UNP400	HEB340	HEB360	HEB400	HEB450	HEB450	HEB500	HEB550	HEB550	HEB600	HEB600	HEB650	HEB650	HEB700
	180	200	220	220	220	220	240	260	280	280	280	300	300	320	320	340
	240	260	280	280	280	280	300	320	340	340	340	360	360	380	380	400
	240	260	280	280	280	280	300	320	340	340	340	360	360	380	380	400
	50	50	55	60	65	65	70	75	80	85	90	95	95	100	105	110
	94.0	100.0	105.0	111.0	116.0	122.0	128.0	133.0	139.0	144.0	150.0	155.0	161.0	166.0	172.0	177.0

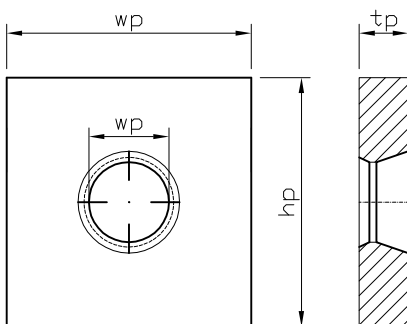

	M85	M90	M95	M100	M105	M110	M115	M120	M125	M130	M135	M140	M145	M150	M155	M160
	UNP380	UNP400	UNP400	HEB340	HEB360	HEB400	HEB450	HEB450	HEB500	HEB550	HEB550	HEB600	HEB600	HEB650	HEB650	HEB700
	200	220	220	220	240	260	270	280	300	310	330	340	360	380	400	420
	240	260	280	280	280	280	300	320	340	340	340	360	360	380	380	400
	260	280	280	280	300	320	330	340	360	370	390	400	420	440	460	480
	55	55	55	60	70	70	75	80	85	90	100	105	105	110	120	125
	104.0	110.0	116.0	122.0	128.0	134.0	140.0	146.0	152.0	158.0	164.0	170.0	176.0	182.0	188.0	195.0

**Rear plates for Anchor ASF460**

to 1993-5 with kt 0,9 in S355



**Typ I – angle 0°**

Nominal diameter	ØD	(mm)	M39	M42	M45	M48	M52	M56	M60	M64	M68	M72	M76	M80
<b>Waling</b>			UNP220	UNP220	UNP240	UNP240	UNP260	UNP280	UNP300	UNP320	UNP320	UNP350	UNP380	UNP400
Waling spacing			80	80	80	80	80	80	100	100	100	100	100	100
Width	wp	(mm)	160	160	180	180	180	200	200	200	220	220	240	240
Height	hp	(mm)	140	140	140	140	140	140	160	160	160	160	160	160
Thickness	tp	(mm)	25	30	35	35	35	40	40	40	40	40	40	45
Drilling	Ød	(mm)	45.0	48.0	51.0	54.0	58.0	62.0	66.0	70.0	74.0	78.0	82.0	86.0



**Typ III – angle up to max. 5°**

Nominal diameter	ØD	(mm)	M39	M42	M45	M48	M52	M56	M60	M64	M68	M72	M76	M80
<b>Waling</b>			UNP220	UNP220	UNP240	UNP240	UNP260	UNP280	UNP300	UNP320	UNP320	UNP350	UNP380	UNP400
Waling spacing			100	100	120	120	120	140	140	140	160	160	180	180
Width	wp	(mm)	160	160	180	180	180	200	200	200	220	220	240	240
Height	hp	(mm)	160	160	180	180	180	200	200	200	220	220	240	240
Thickness	tp	(mm)	25	30	35	35	35	40	45	45	50	50	55	60
Drilling	Ød	(mm)	45.0	48.0	51.0	54.0	58.0	62.0	67.0	71.0	76.0	80.0	84.0	89.0



**Typ II – angle up to max. 10°**

Nominal diameter	ØD	(mm)	M39	M42	M45	M48	M52	M56	M60	M64	M68	M72	M76	M80
<b>Waling</b>			UNP220	UNP220	UNP240	UNP240	UNP260	UNP280	UNP300	UNP320	UNP320	UNP350	UNP380	UNP400
Waling spacing			100	100	120	120	120	140	140	160	160	180	180	180
Width	wp	(mm)	160	160	180	180	180	200	200	200	220	220	240	240
Height	hp	(mm)	160	160	180	180	180	200	200	220	220	240	240	240
Thickness	tp	(mm)	25	30	35	35	35	40	45	50	50	55	55	60
Drilling	Ød	(mm)	46.0	50.0	53.0	57.0	61.0	66.0	71.0	75.0	80.0	85.0	89.0	94.0

# 4

## ANCHOR/WALING JOINTS

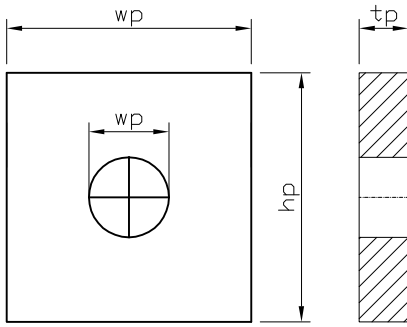

	M85	M90	M95	M100	M105	M110	M115	M120	M125	M130	M135	M140	M145	M150	M155	M160
	HEB340	HEB360	HEB400	HEB450	HEB450	HEB500	HEB550	HEB550	HEB600	HEB650	HEB700	HEB700	HEB800	HEB800	HEB900	HEB900
	120	120	120	140	140	140	140	140	160	160	160	160	180	180	180	180
	240	260	280	280	280	280	300	320	340	340	340	360	360	380	380	400
	180	180	180	200	200	200	200	200	220	220	220	220	240	240	240	240
	50	50	60	60	65	65	65	70	70	75	75	75	80	80	85	85
	91.0	96.0	101.0	106.0	111.0	116.0	121.0	126.0	131.0	136.0	141.0	146.0	151.0	156.0	161.0	166.0

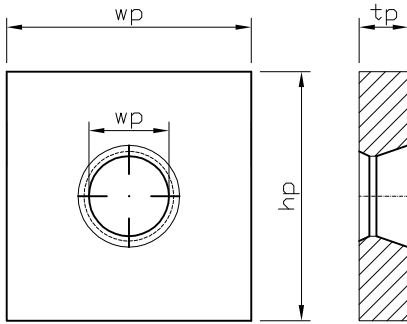

	M85	M90	M95	M100	M105	M110	M115	M120	M125	M130	M135	M140	M145	M150	M155	M160
	HEB340	HEB360	HEB400	HEB450	HEB450	HEB500	HEB550	HEB550	HEB600	HEB650	HEB700	HEB700	HEB800	HEB800	HEB900	HEB900
	180	200	220	220	220	220	240	260	280	280	280	300	300	320	320	340
	240	260	280	280	280	280	300	320	340	340	340	360	360	380	380	400
	240	260	280	280	280	280	300	320	340	340	340	360	360	380	380	400
	65	65	70	75	85	85	90	95	100	110	115	120	120	125	135	140
	94.0	100.0	105.0	111.0	116.0	122.0	128.0	133.0	139.0	144.0	150.0	155.0	161.0	166.0	172.0	177.0

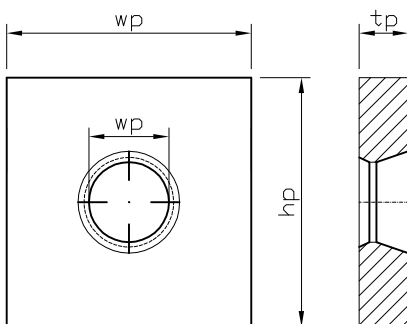

	M85	M90	M95	M100	M105	M110	M115	M120	M125	M130	M135	M140	M145	M150	M155	M160
	HEB340	HEB360	HEB400	HEB450	HEB450	HEB500	HEB550	HEB550	HEB600	HEB650	HEB700	HEB700	HEB800	HEB800	HEB900	HEB900
	200	220	220	220	240	260	270	280	300	310	330	340	360	380	400	420
	240	260	280	280	280	280	300	320	340	340	340	360	360	380	380	400
	260	280	280	280	300	320	330	340	360	370	390	400	420	440	460	480
	70	70	70	75	90	95	95	100	105	115	125	130	130	135	150	155
	100.0	106.0	112.0	118.0	123.0	129.0	135.0	141.0	147.0	153.0	159.0	164.0	170.0	176.0	182.0	188.0

**Rear plates for Anchor ASF500**

to 1993-5 with kt 0,9 in S355



**Typ I – angle 0°**

Nominal diameter	ØD	(mm)	M39	M42	M45	M48	M52	M56	M60	M64	M68	M72	M76	M80
<b>Waling</b>			UNP220	UNP220	UNP240	UNP240	UNP260	UNP280	UNP300	UNP320	UNP320	UNP350	UNP380	UNP400
Waling spacing			80	80	80	80	80	80	100	100	100	100	100	100
Width	wp	(mm)	160	160	180	180	180	200	200	200	220	220	240	240
Height	hp	(mm)	140	140	140	140	140	140	160	160	160	160	160	160
Thickness	tp	(mm)	25	30	35	35	35	40	40	40	40	40	40	45
Drilling	Ød	(mm)	45.0	48.0	51.0	54.0	58.0	62.0	66.0	70.0	74.0	78.0	82.0	86.0



**Typ III – angle up to max. 5°**

Nominal diameter	ØD	(mm)	M39	M42	M45	M48	M52	M56	M60	M64	M68	M72	M76	M80
<b>Waling</b>			UNP220	UNP220	UNP240	UNP240	UNP260	UNP280	UNP300	UNP320	UNP320	UNP350	UNP380	UNP400
Waling spacing			100	100	120	120	120	140	140	140	160	160	180	180
Width	wp	(mm)	160	160	180	180	180	200	200	200	220	220	240	240
Height	hp	(mm)	160	160	180	180	180	200	200	200	220	220	240	240
Thickness	tp	(mm)	25	30	35	35	35	40	45	45	50	50	55	60
Drilling	Ød	(mm)	45.0	48.0	51.0	54.0	58.0	62.0	67.0	71.0	76.0	80.0	84.0	89.0



**Typ II – angle up to max. 10°**

Nominal diameter	ØD	(mm)	M39	M42	M45	M48	M52	M56	M60	M64	M68	M72	M76	M80
<b>Waling</b>			UNP220	UNP220	UNP240	UNP240	UNP260	UNP280	UNP300	UNP320	UNP320	UNP350	UNP380	UNP400
Waling spacing			100	100	120	120	120	140	140	160	160	180	180	180
Width	wp	(mm)	160	160	180	180	180	200	200	200	220	220	240	240
Height	hp	(mm)	160	160	180	180	180	200	200	220	220	240	240	240
Thickness	tp	(mm)	25	30	35	35	35	40	45	50	50	55	55	60
Drilling	Ød	(mm)	46.0	50.0	53.0	57.0	61.0	66.0	71.0	75.0	80.0	85.0	89.0	94.0

# 4

## ANCHOR/WALING JOINTS

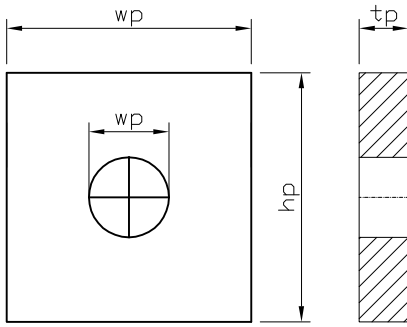

	M85	M90	M95	M100	M105	M110	M115	M120	M125	M130	M135	M140	M145	M150	M155	M160
	HEB340	HEB360	HEB400	HEB450	HEB450	HEB500	HEB550	HEB550	HEB600	HEB650	HEB700	HEB700	HEB800	HEB800	HEB900	HEB900
	120	120	120	140	140	140	140	140	160	160	160	160	180	180	180	180
	240	260	280	280	280	280	300	320	340	340	340	360	360	380	380	400
	180	180	180	200	200	200	200	200	220	220	220	220	240	240	240	240
	50	50	60	60	65	65	65	70	70	75	75	75	80	80	85	85
	91.0	96.0	101.0	106.0	111.0	116.0	121.0	126.0	131.0	136.0	141.0	146.0	151.0	156.0	161.0	166.0

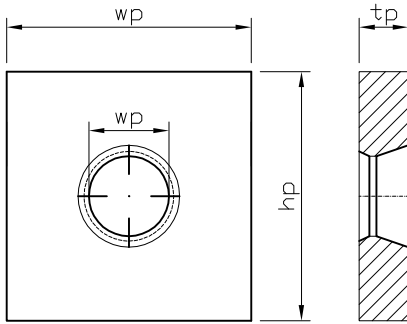

	M85	M90	M95	M100	M105	M110	M115	M120	M125	M130	M135	M140	M145	M150	M155	M160
	HEB340	HEB360	HEB400	HEB450	HEB450	HEB500	HEB550	HEB550	HEB600	HEB650	HEB700	HEB700	HEB800	HEB800	HEB900	HEB900
	180	200	220	220	220	220	240	260	280	280	280	300	300	320	320	340
	240	260	280	280	280	280	300	320	340	340	340	360	360	380	380	400
	240	260	280	280	280	280	300	320	340	340	340	360	360	380	380	400
	65	65	70	75	85	85	90	95	100	110	115	120	120	125	135	140
	94.0	100.0	105.0	111.0	116.0	122.0	128.0	133.0	139.0	144.0	150.0	155.0	161.0	166.0	172.0	177.0

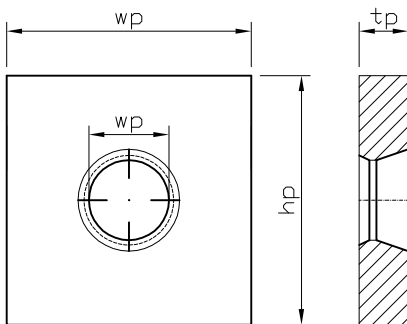

	M85	M90	M95	M100	M105	M110	M115	M120	M125	M130	M135	M140	M145	M150	M155	M160
	HEB340	HEB360	HEB400	HEB450	HEB450	HEB500	HEB550	HEB550	HEB600	HEB650	HEB700	HEB700	HEB800	HEB800	HEB900	HEB900
	200	220	220	220	240	260	270	280	300	310	330	340	360	380	400	420
	240	260	280	280	280	280	300	320	340	340	340	360	360	380	380	400
	260	280	280	280	300	320	330	340	360	370	390	400	420	440	460	480
	70	70	70	75	90	95	95	100	105	115	125	130	130	135	150	155
	100.0	106.0	112.0	118.0	123.0	129.0	135.0	141.0	147.0	153.0	159.0	164.0	170.0	176.0	182.0	188.0

**Rear plates for Anchor ASF600**

to 1993-5 with kt 0,9 in S355



**Typ I – angle 0°**

Nominal diameter	ØD	(mm)	M39	M42	M45	M48	M52	M56	M60	M64	M68	M72	M76	M80
<b>Waling</b>			UNP220	UNP240	UNP260	UNP280	UNP300	UNP320	UNP320	UNP350	UNP380	UNP400	HEB340	HEB360
Waling spacing			80	80	80	80	80	80	100	100	100	100	100	100
Width	wp	(mm)	160	160	180	180	180	200	200	200	220	220	240	240
Height	hp	(mm)	140	140	140	140	140	140	160	160	160	160	160	160
Thickness	tp	(mm)	30	35	35	35	35	40	40	40	45	45	45	50
Drilling	Ød	(mm)	45.0	48.0	51.0	54.0	58.0	62.0	66.0	70.0	74.0	78.0	82.0	86.0



**Typ III – angle up to max. 5°**

Nominal diameter	ØD	(mm)	M39	M42	M45	M48	M52	M56	M60	M64	M68	M72	M76	M80
<b>Waling</b>			UNP220	UNP240	UNP260	UNP280	UNP300	UNP320	UNP320	UNP350	UNP380	UNP400	HEB340	HEB360
Waling spacing			100	100	120	120	120	140	140	140	160	160	180	180
Width	wp	(mm)	160	160	180	180	180	200	200	200	220	220	240	240
Height	hp	(mm)	160	160	180	180	180	200	200	200	220	220	240	240
Thickness	tp	(mm)	30	30	35	35	35	40	50	50	55	55	60	60
Drilling	Ød	(mm)	45.0	48.0	51.0	54.0	58.0	62.0	67.0	71.0	76.0	80.0	84.0	89.0



**Typ II – angle up to max. 10°**

Nominal diameter	ØD	(mm)	M39	M42	M45	M48	M52	M56	M60	M64	M68	M72	M76	M80
<b>Waling</b>			UNP220	UNP240	UNP260	UNP280	UNP300	UNP320	UNP320	UNP350	UNP380	UNP400	HEB340	HEB360
Waling spacing			100	100	120	120	120	140	140	160	160	180	180	180
Width	wp	(mm)	160	160	180	180	180	200	200	200	220	220	240	240
Height	hp	(mm)	160	160	180	180	180	200	200	220	220	240	240	240
Thickness	tp	(mm)	30	30	35	35	35	40	50	55	55	60	60	60
Drilling	Ød	(mm)	45.0	49.0	52.0	56.0	60.0	65.0	69.0	74.0	79.0	83.0	88.0	92.0

# 4

## ANCHOR/WALING JOINTS

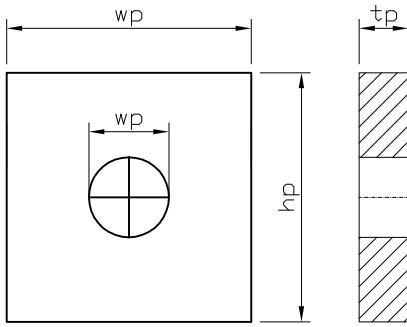

	M85	M90	M95	M100	M105	M110	M115	M120	M125	M130	M135	M140	M145	M150	M155	M160
	HEB400	HEB450	HEB450	HEB500	HEB550	HEB600	HEB650	HEB650	HEB700	HEB800	HEB800	HEB800	HEB900	HEB900	HEB1000	HEB1000
	120	120	120	140	140	140	140	140	160	160	160	160	180	180	180	180
	240	260	280	280	280	280	300	320	340	340	340	360	360	380	380	400
	180	180	180	200	200	200	200	200	220	220	220	220	240	240	240	240
	60	60	65	65	70	70	70	75	75	80	80	85	90	90	95	95
	91.0	96.0	101.0	106.0	111.0	116.0	121.0	126.0	131.0	136.0	141.0	146.0	151.0	156.0	161.0	166.0

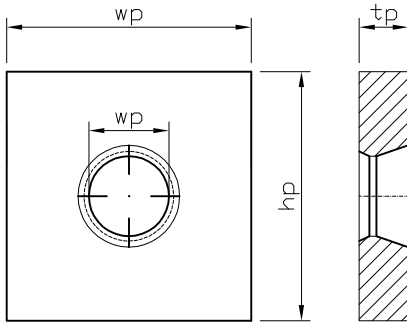

	M85	M90	M95	M100	M105	M110	M115	M120	M125	M130	M135	M140	M145	M150	M155	M160
	HEB400	HEB450	HEB450	HEB500	HEB550	HEB600	HEB650	HEB650	HEB700	HEB800	HEB800	HEB800	HEB900	HEB900	HEB1000	HEB1000
	180	200	220	220	220	220	240	260	280	280	280	300	300	320	320	340
	240	260	280	280	280	280	300	320	340	340	340	360	360	380	380	400
	240	260	280	280	280	280	300	320	340	340	340	360	360	380	380	400
	65	65	75	80	85	85	95	100	105	110	120	125	125	130	140	145
	94.0	100.0	105.0	111.0	116.0	122.0	128.0	133.0	139.0	144.0	150.0	155.0	161.0	166.0	172.0	177.0

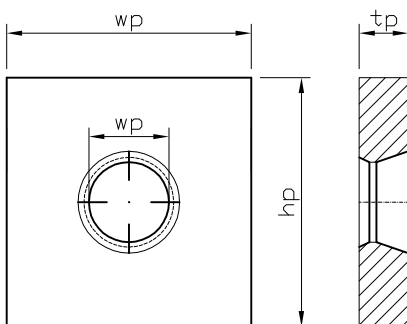

	M85	M90	M95	M100	M105	M110	M115	M120	M125	M130	M135	M140	M145	M150	M155	M160
	HEB400	HEB450	HEB450	HEB500	HEB550	HEB600	HEB650	HEB650	HEB700	HEB800	HEB800	HEB800	HEB900	HEB900	HEB1000	HEB1000
	200	220	220	220	240	260	270	280	300	310	330	340	360	380	400	420
	240	260	280	280	280	280	300	320	340	340	340	360	360	380	380	400
	260	280	280	280	300	320	330	340	360	370	390	400	420	440	460	480
	70	70	75	80	90	95	100	105	110	115	130	135	140	140	155	160
	98.0	104.0	110.0	115.0	121.0	127.0	133.0	138.0	144.0	150.0	156.0	162.0	167.0	173.0	179.0	185.0

**Rear plates for Anchor ASF720**

to 1993-5 with kt 0,9 in S355



**Typ I – angle 0°**

Nominal diameter	ØD	(mm)	M39	M42	M45	M48	M52	M56	M60	M64	M68	M72	M76	M80
<b>Waling</b>			UNP260	UNP280	UNP280	UNP300	UNP320	UNP350	UNP380	UNP400	HEB340	HEB360	HEB400	HEB400
Waling spacing			80	80	80	80	80	80	100	100	100	100	100	100
Width	wp	(mm)	160	160	180	180	180	200	200	200	220	220	240	240
Height	hp	(mm)	140	140	140	140	140	140	160	160	160	160	160	160
Thickness	tp	(mm)	35	40	40	45	45	50	50	50	55	55	55	60
Drilling	Ød	(mm)	45.0	48.0	51.0	54.0	58.0	62.0	66.0	70.0	74.0	78.0	82.0	86.0



**Typ III – angle up to max. 5°**

Nominal diameter	ØD	(mm)	M39	M42	M45	M48	M52	M56	M60	M64	M68	M72	M76	M80
<b>Waling</b>			UNP260	UNP280	UNP280	UNP300	UNP320	UNP350	UNP380	UNP400	HEB340	HEB360	HEB400	HEB400
Waling spacing			100	100	120	120	120	140	140	140	160	160	180	180
Width	wp	(mm)	160	160	180	180	180	200	200	200	220	220	240	240
Height	hp	(mm)	160	160	180	180	180	200	200	200	220	220	240	240
Thickness	tp	(mm)	35	35	40	40	45	50	60	60	65	65	70	70
Drilling	Ød	(mm)	45.0	48.0	51.0	54.0	58.0	62.0	67.0	71.0	76.0	80.0	84.0	89.0



**Typ II – angle up to max. 10°**

Nominal diameter	ØD	(mm)	M39	M42	M45	M48	M52	M56	M60	M64	M68	M72	M76	M80
<b>Waling</b>			UNP260	UNP280	UNP280	UNP300	UNP320	UNP350	UNP380	UNP400	HEB340	HEB360	HEB400	HEB400
Waling spacing			100	100	120	120	120	140	140	160	160	180	180	180
Width	wp	(mm)	160	160	180	180	180	200	200	200	220	220	240	240
Height	hp	(mm)	160	160	180	180	180	200	200	220	220	240	240	240
Thickness	tp	(mm)	35	35	40	40	45	50	60	65	65	70	70	75
Drilling	Ød	(mm)	45.0	49.0	52.0	56.0	60.0	65.0	69.0	74.0	79.0	83.0	88.0	92.0

# 4

## ANCHOR/WALING JOINTS

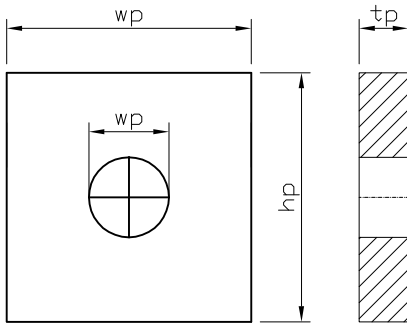

	M85	M90	M95	M100	M105	M110	M115	M120	M125	M130	M135	M140	M145	M150	M155	M160
	HEB450	HEB500	HEB550	HEB550	HEB550	HEB550	HEB600	HEB650	HEB700	HEB700	HEB800	HEB800	HEB900	HEB900	HEB1000	HEB1000
	120	120	120	140	140	140	140	140	160	160	160	160	180	180	180	180
	240	260	280	280	280	280	300	320	340	340	340	360	360	380	380	400
	180	180	180	200	200	200	200	200	220	220	220	220	240	240	240	240
	70	70	75	80	80	85	85	90	90	95	95	100	105	110	110	115
	91.0	96.0	101.0	106.0	111.0	116.0	121.0	126.0	131.0	136.0	141.0	146.0	151.0	156.0	161.0	166.0

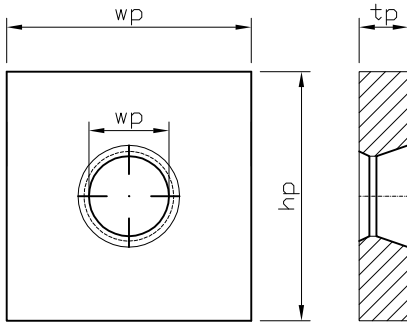

	M85	M90	M95	M100	M105	M110	M115	M120	M125	M130	M135	M140	M145	M150	M155	M160
	HEB450	HEB500	HEB550	HEB550	HEB550	HEB550	HEB600	HEB650	HEB700	HEB700	HEB800	HEB800	HEB900	HEB900	HEB1000	HEB1000
	180	200	220	220	220	220	240	260	280	280	280	300	300	320	320	340
	240	260	280	280	280	280	300	320	340	340	340	360	360	380	380	400
	240	260	280	280	280	280	300	320	340	340	340	360	360	380	380	400
	75	80	90	95	100	100	110	120	125	130	140	150	150	155	165	175
	94.0	100.0	105.0	111.0	116.0	122.0	128.0	133.0	139.0	144.0	150.0	155.0	161.0	166.0	172.0	177.0

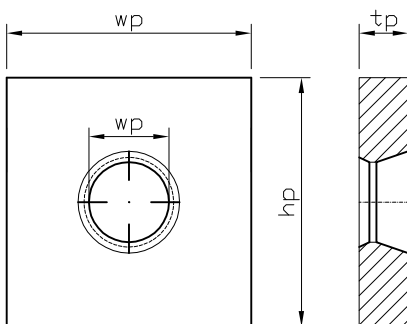

	M85	M90	M95	M100	M105	M110	M115	M120	M125	M130	M135	M140	M145	M150	M155	M160
	HEB450	HEB500	HEB550	HEB550	HEB550	HEB550	HEB600	HEB650	HEB700	HEB700	HEB800	HEB800	HEB900	HEB900	HEB1000	HEB1000
	200	220	220	220	240	260	270	280	300	310	330	340	360	380	400	420
	240	260	280	280	280	280	300	320	340	340	340	360	360	380	380	400
	260	280	280	280	300	320	330	340	360	370	390	400	420	440	460	480
	75	80	90	95	105	110	120	125	130	135	155	160	165	170	185	190
	98.0	104.0	110.0	115.0	121.0	127.0	133.0	138.0	144.0	150.0	156.0	162.0	167.0	173.0	179.0	185.0

**Rear plates for Anchor ASF900**

to 1993-5 with kt 0,9 in S690



**Typ I – angle 0°**

Nominal diameter	ØD	(mm)	M39	M42	M45	M48	M52	M56	M60	M64	M68	M72	M76	M80
<b>Waling</b>			UNP260	UNP280	UNP280	UNP300	UNP320	UNP350	UNP380	UNP400	HEB340	HEB360	HEB400	HEB400
Waling spacing			80	80	80	80	80	80	100	100	100	100	100	100
Width	wp	(mm)	160	160	180	180	180	200	200	200	220	220	240	240
Height	hp	(mm)	140	140	140	140	140	140	160	160	160	160	160	160
Thickness	tp	(mm)	25	25	30	30	30	35	35	35	35	35	35	40
Drilling	Ød	(mm)	45.0	48.0	51.0	54.0	58.0	62.0	66.0	70.0	74.0	78.0	82.0	86.0



**Typ III – angle up to max. 5°**

Nominal diameter	ØD	(mm)	M39	M42	M45	M48	M52	M56	M60	M64	M68	M72	M76	M80
<b>Waling</b>			UNP260	UNP280	UNP280	UNP300	UNP320	UNP350	UNP380	UNP400	HEB340	HEB360	HEB400	HEB400
Waling spacing			100	100	120	120	120	140	140	140	160	160	180	180
Width	wp	(mm)	160	160	180	180	180	200	200	200	220	220	240	240
Height	hp	(mm)	160	160	180	180	180	200	200	200	220	220	240	240
Thickness	tp	(mm)	25	25	30	30	30	35	40	40	45	45	50	50
Drilling	Ød	(mm)	45.0	48.0	51.0	54.0	58.0	62.0	67.0	71.0	76.0	80.0	84.0	89.0



**Typ II – angle up to max. 10°**

Nominal diameter	ØD	(mm)	M39	M42	M45	M48	M52	M56	M60	M64	M68	M72	M76	M80
<b>Waling</b>			UNP260	UNP280	UNP280	UNP300	UNP320	UNP350	UNP380	UNP400	HEB340	HEB360	HEB400	HEB400
Waling spacing			100	100	120	120	120	140	140	160	160	180	180	180
Width	wp	(mm)	160	160	180	180	180	200	200	200	220	220	240	240
Height	hp	(mm)	160	160	180	180	180	200	200	220	220	240	240	240
Thickness	tp	(mm)	25	25	30	30	30	35	40	45	45	50	50	50
Drilling	Ød	(mm)	45.0	49.0	52.0	56.0	60.0	65.0	70.0	74.0	79.0	83.0	88.0	92.0

# 4

## ANCHOR/WALING JOINTS

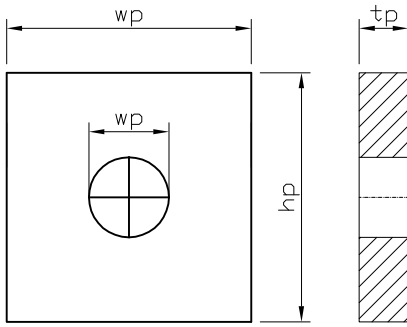

	M85	M90	M95	M100	M105	M110	M115	M120	M125	M130	M135	M140	M145	M150	M155	M160
	HEB450	HEB500	HEB550	HEB550	HEB550	HEB550	HEB600	HEB650	HEB700	HEB700	HEB800	HEB800	HEB900	HEB900	HEB1000	HEB1000
	120	120	120	140	140	140	140	140	160	160	160	160	180	180	180	180
	240	260	280	280	280	280	300	320	340	340	340	360	360	380	380	400
	180	180	180	200	200	200	200	200	220	220	220	220	240	240	240	240
	45	45	50	50	55	55	55	60	60	65	65	65	70	70	75	75
	91.0	96.0	101.0	106.0	111.0	116.0	121.0	126.0	131.0	136.0	141.0	146.0	151.0	156.0	161.0	166.0

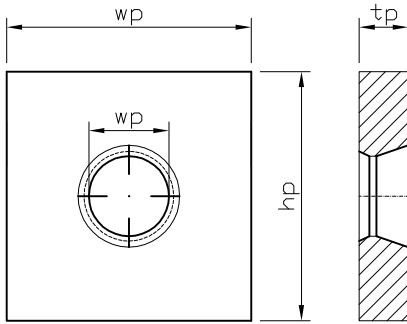

	M85	M90	M95	M100	M105	M110	M115	M120	M125	M130	M135	M140	M145	M150	M155	M160
	HEB450	HEB500	HEB550	HEB550	HEB550	HEB550	HEB600	HEB650	HEB700	HEB700	HEB800	HEB800	HEB900	HEB900	HEB1000	HEB1000
	180	200	220	220	220	220	240	260	280	280	280	300	300	320	320	340
	240	260	280	280	280	280	300	320	340	340	340	360	360	380	380	400
	240	260	280	280	280	280	300	320	340	340	340	360	360	380	380	400
	55	55	60	65	70	70	75	80	90	90	100	110	110	120	120	125
	94.0	100.0	105.0	111.0	116.0	122.0	128.0	133.0	139.0	144.0	150.0	155.0	161.0	166.0	172.0	177.0

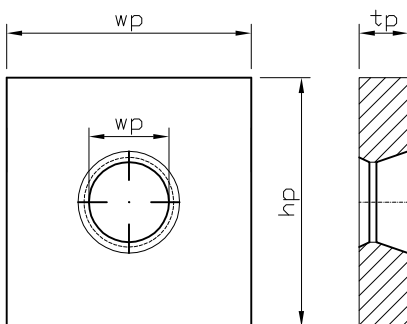

	M85	M90	M95	M100	M105	M110	M115	M120	M125	M130	M135	M140	M145	M150	M155	M160
	HEB450	HEB500	HEB550	HEB550	HEB550	HEB550	HEB600	HEB650	HEB700	HEB700	HEB800	HEB800	HEB900	HEB900	HEB1000	HEB1000
	200	220	220	220	240	260	270	280	300	310	330	340	360	380	400	420
	240	260	280	280	280	280	300	320	340	340	340	360	360	380	380	400
	260	280	280	280	300	320	330	340	360	370	390	400	420	440	460	480
	60	60	60	65	75	75	80	85	95	95	110	120	120	130	135	140
	98.0	104.0	110.0	115.0	121.0	127.0	133.0	138.0	144.0	150.0	156.0	162.0	167.0	173.0	179.0	185.0

**Complete systems**

Typical examples of complete systems

This option is used to compensate for shallow angles of up to max. 5°. The turnbuckle (left- and right-hand threads) is used to tension the anchorage and adjust the total length of the anchor.

**Components used:**

Spherical nut > End plate with spherical recess > Anchor thread–thread > Turnbuckle > Anchor thread–thread > End plate with spherical recess > Spherical

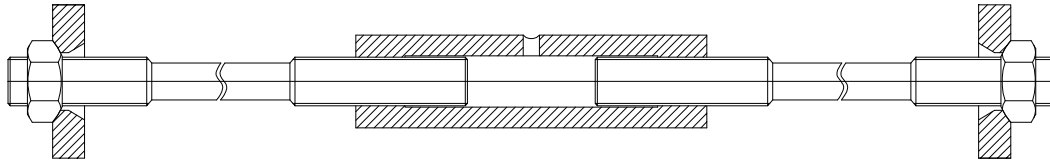

Typical application for a “dead man” anchorage, without rotational movement.

**Components used:**

Nut > Rear plate > Anchor thread–thread > Turnbuckle > Anchor thread–thread > Rear plate > Nut

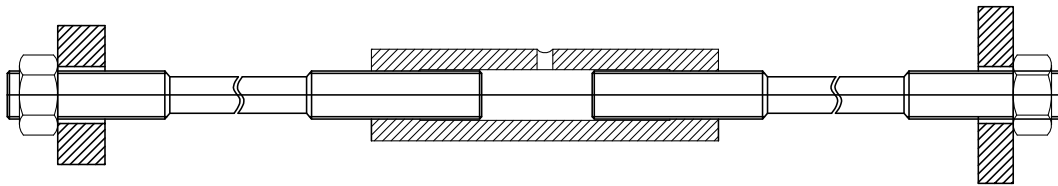

Anchorage for combined sheet piling with tubular piles.

**Components used:**

Pipe > Plate > Nut > Eye rod > Shackle joint > Eye rod > Turnbuckle > Anchor thread–thread > End plate with spherical recess > Spherical nut

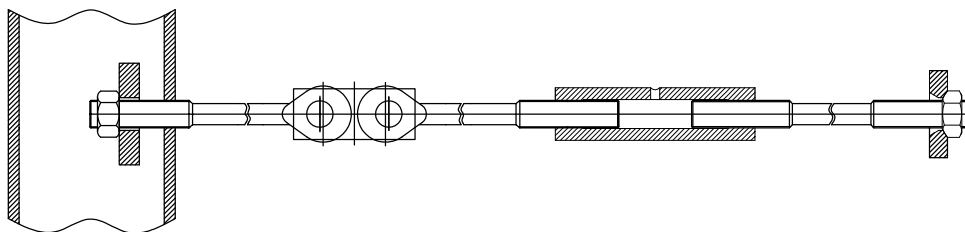

Good solution for combined sheet piling when using grades ASF600 and ASF900.

**Components used:**

Pipe > Plate > Nut > Eye rod > Shackle joint turnbuckle > Anchor thread–thread > Turnbuckle > Anchor thread–thread > Plate > Nut

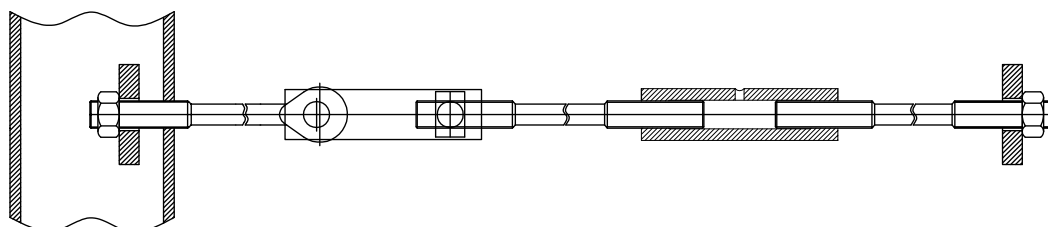

Typical option for anchors connected to tubular piles.

**Components used:**

Tube, T-connection, eye rod > Turnbuckle > Anchor thread–thread > Coupler > Anchor thread–thread > End plate with spherical recess > Spherical nut

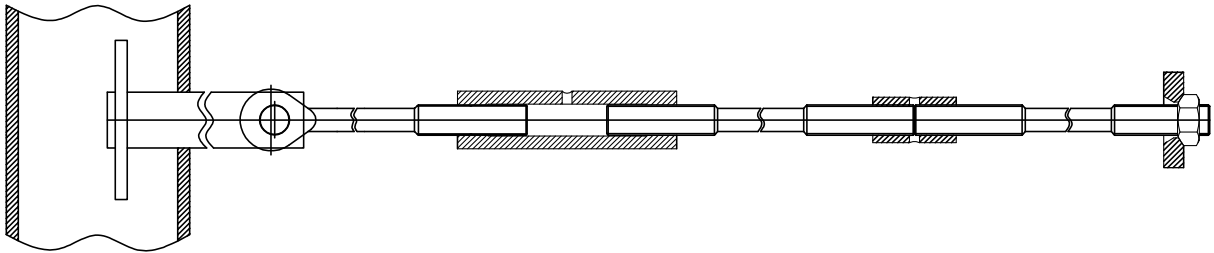

Popular system solution for heavy-duty walls with steel sections.

**Components used:**

HZ section > T-connection > Eye rod > Turnbuckle > Anchor thread–thread > Coupler > Anchor thread–thread > End plate with spherical recess > Spherical nut

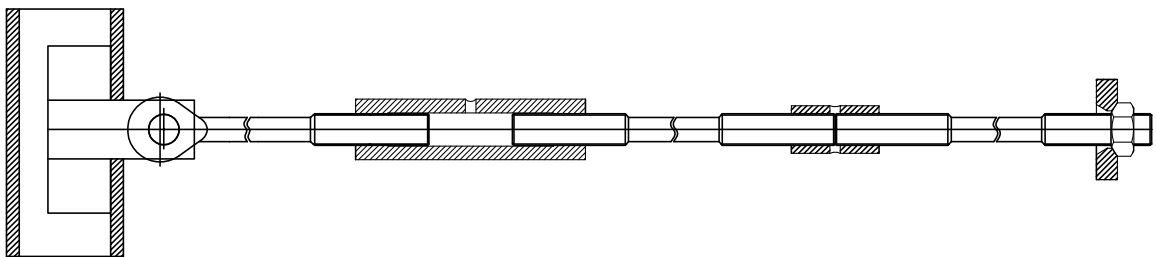

Alternative concrete connection option permitting rotational movement in all directions.

**Components used:**

Concrete > Nut > Plate > Anchor thread–thread > Ball fitting > Anchor with head for ball fitting > Turnbuckle > Anchor thread–thread > Plate > Nut

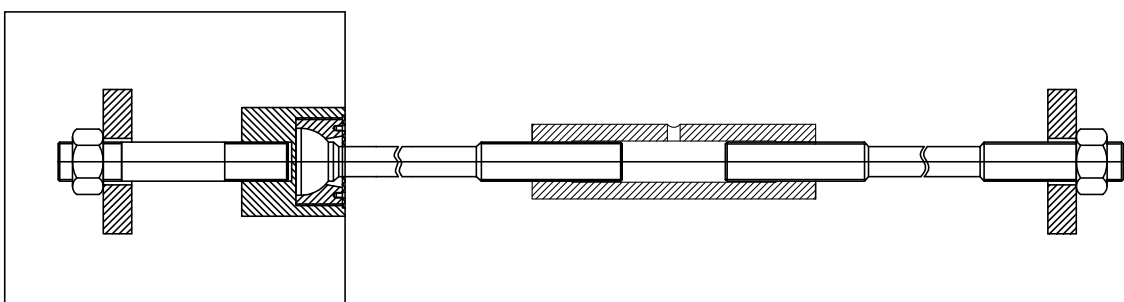

**Eye anchor**

ASF355 - ASF500 - ASF720



ASF355-Anchor force to DIN EN 1993-5 - kt 0,6			A150	A175	A200	A200	A225	A225	A225	A250	A275	A300A
			M39	M42	M45	M48	M52	M56	M60	M64	M68	M72
Shaft diameter	d	mm	36	39	42	42	45	45	45	48	52	56
Thickness Eye	c	mm	25	30	33	33	39	39	39	42	47	50
Length Eye	La	mm	86	106	127	127	135	135	135	147	166	190
Width Eye	a	mm	72	85	105	105	110	110	110	125	135	155
Bolt diameter	d0	mm	30	33	36	36	40	40	40	47	52	56

ASF500-Anchor force to DIN EN 1993-5 - kt 0,6			A150	A175	A200	A200	A225	A225	A225	A250	A275	A300A
			M39	M42	M45	M48	M52	M56	M60	M64	M68	M72
Shaft diameter	d	mm	36	39	42	42	45	45	45	48	52	56
Thickness Eye	c	mm	25	30	33	33	39	39	39	42	47	50
Length Eye	La	mm	86	106	127	127	135	135	135	147	166	190
Width Eye	a	mm	72	85	105	105	110	110	110	125	135	155
Bolt diameter	d0	mm	30	33	36	36	41	41	41	47	52	56

ASF720-Anchor force to DIN EN 1993-5 - kt 0,6			A150	A175	A200	A200	A225	A225	A225	A250	A275	A300A
			M39	M42	M45	M48	M52	M56	M60	M64	M68	M72
Shaft diameter	d	mm	36	39	42	42	45	45	45	48	52	56
Thickness Eye	c	mm	25	30	33	33	39	39	39	42	47	50
Length Eye	La	mm	86	106	127	127	135	135	135	147	166	190
Width Eye	a	mm	72	85	105	105	110	110	110	125	135	155
Bolt diameter	d0	mm	30	33	40	40	44	44	44	50	55	61



# 5

## EYE ANCHOR

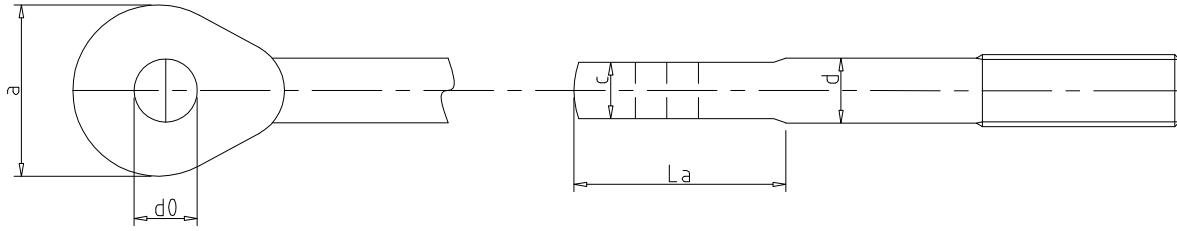

	A300B	A325	A350	A375A	A375B	A400	A425	A450	A450	A475	A500	A525	A550	A575	A575	A600	A625	A650
	M76	M80	M85	M90	M95	M100	M105	M110	M115	M120	M125	M130	M135	M140	M145	M150	M155	M160
	60	64	68	72	75	80	85	90	90	95	100	105	110	115	115	120	125	130
	50	55	60	63	63	66	72	75	75	80	85	90	95	100	100	105	115	120
	190	210	220	235	235	253	290	300	300	323	340	350	365	373	373	380	439	459
	155	165	180	190	190	210	230	240	240	255	270	275	290	300	300	310	330	340
	56	62	68	70	70	76	80	85	85	90	95	100	100	105	105	110	115	120

	A300B	A325	A350	A375A	A375B	A400	A425	A450	A450	A475	A500	A525	A550	A575	A575	A600	A625	A650
	M76	M80	M85	M90	M95	M100	M105	M110	M115	M120	M125	M130	M135	M140	M145	M150	M155	M160
	60	64	68	72	75	80	85	90	90	95	100	105	110	115	115	120	125	130
	50	55	60	63	63	66	72	75	75	80	85	90	95	100	100	105	115	120
	190	210	220	235	235	253	290	300	300	323	340	350	365	373	373	380	439	459
	155	165	180	190	190	210	230	240	240	255	270	275	290	300	300	310	330	340
	56	62	68	70	70	76	80	85	85	90	95	100	105	110	110	115	120	125

	A300B	A325	A350	A375A	A375B	A400	A425	A450	A450	A475	A500	A525	A550	A575	A575	A600	A625	A650
	M76	M80	M85	M90	M95	M100	M105	M110	M115	M120	M125	M130	M135	M140	M145	M150	M155	M160
	60	64	68	72	75	80	85	90	90	95	100	105	110	115	115	120	125	130
	50	55	60	63	63	66	72	75	75	80	85	90	95	100	100	105	115	120
	190	210	220	235	235	253	290	300	300	323	340	350	365	373	373	380	439	459
	155	165	180	190	190	210	230	240	240	255	270	275	290	300	300	310	330	340
	61	66	72	76	76	85	90	95	95	100	105	110	110	115	115	125	130	135



**Shackle joint**

ASF355 - ASF500 - ASF720



ASF355-Anchor force to DIN EN 1993-5 - kt 0,6			A150	A175	A200	A200	A225	A225	A225	A250	A275	A300A
			M39	M42	M45	M48	M52	M56	M60	M64	M68	M72
Length (plate)	a	mm	220	245	275	275	295	295	295	340	370	405
Height (plate)	b	mm	80	90	100	100	110	110	110	130	140	150
Thickness (plate)	c	mm	15	15	20	20	20	20	20	25	25	25
Hole spacing (plate)	e	mm	115	130	150	150	160	160	160	180	195	215
Diameter (bolt)	g	mm	30	33	36	36	40	40	40	47	52	56
Length (bolt)	k	mm	90	95	110	110	120	120	120	135	140	145

ASF500-Anchor force to DIN EN 1993-5 - kt 0,6			A150	A175	A200	A200	A225	A225	A225	A250	A275	A300A
			M39	M42	M45	M48	M52	M56	M60	M64	M68	M72
Length (plate)	a	mm	220	245	275	275	300	300	300	340	370	405
Height (plate)	b	mm	80	90	100	100	110	110	110	130	140	150
Thickness (plate)	c	mm	15	20	20	20	25	25	25	25	30	30
Hole spacing (plate)	e	mm	115	130	150	150	160	160	160	180	195	215
Diameter (bolt)	g	mm	30	33	36	36	41	41	41	47	52	56
Length (bolt)	k	mm	90	105	110	110	130	130	130	135	150	155

ASF720-Anchor force to DIN EN 1993-5 - kt 0,6			A150	A175	A200	A200	A225	A225	A225	A250	A275	A300A
			M39	M42	M45	M48	M52	M56	M60	M64	M68	M72
Length (plate)	a	mm	220	245	290	290	310	310	310	350	380	425
Height (plate)	b	mm	80	90	110	110	120	120	120	130	150	160
Thickness (plate)	c	mm	20	20	25	25	25	25	25	30	35	35
Hole spacing (plate)	e	mm	115	130	155	155	160	160	160	180	195	220
Diameter (bolt)	g	mm	30	33	40	40	44	44	44	50	55	61
Length (bolt)	k	mm	100	105	120	120	130	130	130	145	160	165



# 6

## CONNECTION ELEMENTS EYE ANCHOR

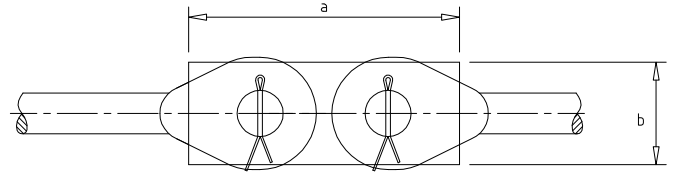
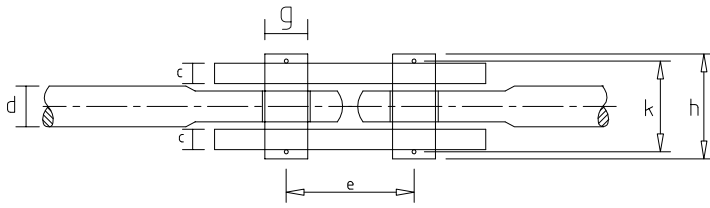

	A300B	A325	A350	A375A	A375B	A400	A425	A450	A450	A475	A500	A525	A550	A575	A575	A600	A625	A650
	M76	M80	M85	M90	M95	M100	M105	M110	M115	M120	M125	M130	M135	M140	M145	M150	M155	M160
	405	435	475	495	495	530	560	595	595	625	660	690	690	720	720	755	780	815
	150	160	180	180	180	200	210	220	220	230	250	260	260	270	270	280	300	310
	30	30	30	35	35	40	40	40	40	45	50	50	50	55	55	55	60	60
	215	230	250	260	260	280	295	315	315	330	345	360	360	375	375	395	405	420
	56	62	68	70	70	76	80	85	85	90	95	100	100	105	105	110	115	120
	160	160	165	180	185	200	205	215	215	230	245	250	255	275	275	280	295	300

	A300B	A325	A350	A375A	A375B	A400	A425	A450	A450	A475	A500	A525	A550	A575	A575	A600	A625	A650
	M76	M80	M85	M90	M95	M100	M105	M110	M115	M120	M125	M130	M135	M140	M145	M150	M155	M160
	405	435	475	495	495	530	560	595	595	625	660	690	710	740	740	775	805	835
	150	160	180	180	180	200	210	220	220	230	250	260	270	280	280	300	310	320
	35	35	40	40	40	45	50	50	50	55	55	60	60	65	65	65	70	70
	215	230	250	260	260	280	295	315	315	330	345	360	365	380	380	400	410	425
	56	62	68	70	70	76	80	85	85	90	95	100	105	110	110	115	120	125
	170	170	185	190	195	210	225	235	235	250	255	270	275	295	295	300	315	320

	A300B	A325	A350	A375A	A375B	A400	A425	A450	A450	A475	A500	A525	A550	A575	A575	A600	A625	A650
	M76	M80	M85	M90	M95	M100	M105	M110	M115	M120	M125	M130	M135	M140	M145	M150	M155	M160
	425	455	495	515	515	570	590	640	640	670	700	730	730	760	760	820	845	875
	160	170	190	200	200	220	230	250	250	260	270	280	280	300	300	320	330	350
	40	40	45	45	45	50	55	55	55	60	65	65	65	70	70	75	75	80
	220	235	255	265	265	290	295	325	325	340	355	370	370	385	385	410	420	435
	61	66	72	76	76	85	90	95	95	100	105	110	110	115	115	125	130	135
	180	180	195	200	205	220	235	245	245	260	275	280	285	305	305	320	325	340



Universal joints for anchor

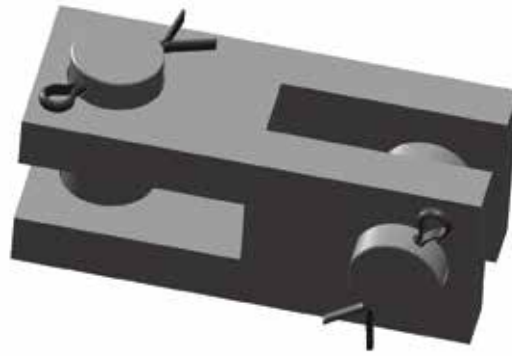

ASF355-Anchor force to DIN EN 1993-5 - kt 0,6			A150	A175	A200	A200	A225	A225	A225	A250	A275	A300A
Nominal diameter	D1	Metrisch	M39	M42	M45	M48	M52	M56	M60	M64	M68	M72
Length (plate)	a	mm	195	220	265	265	305	305	305	330	350	365
Height + width (plate)	b	mm	90	90	110	110	130	130	130	140	150	160
Leg thickness (plate)	c	mm	14	15	17	17	21	21	21	23	24	25
Hole spacing (plate)	e	mm	105	120	150	150	160	160	160	175	190	190
Leg length (plate)	f	mm	91	103	124	124	142	142	142	154	163	170
Diameter (bolt)	g	mm	33	35	41	41	50	50	50	55	58	61
Length (bolt)	k	mm	90	95	105	105	125	125	125	130	140	145

Universal joint at waling for anchor



ASF355-Anchor force to DIN EN 1993-5 - kt 0,6			A150	A175	A200	A200	A225	A225	A225	A250	A275	A300A
Nominal diameter	D1	Metrisch	M39	M42	M45	M48	M52	M56	M60	M64	M68	M72
Length (plate)	a	mm										
Height + width (plate)	b	mm	90	90	110	110	130	130	130	140	150	160
Leg thickness (plate)	c	mm	14	15	17	17	21	21	21	23	24	25
Hole spacing (plate)	e	mm										
Leg length (plate)	f	mm	91	103	124	124	142	142	142	154	163	170
Diameter (bolt)	g	mm	33	35	41	41	50	50	50	55	58	61
Length (bolt)	k	mm	90	95	105	105	125	125	125	130	140	145

# 6

## CONNECTION ELEMENTS EYE ANCHOR

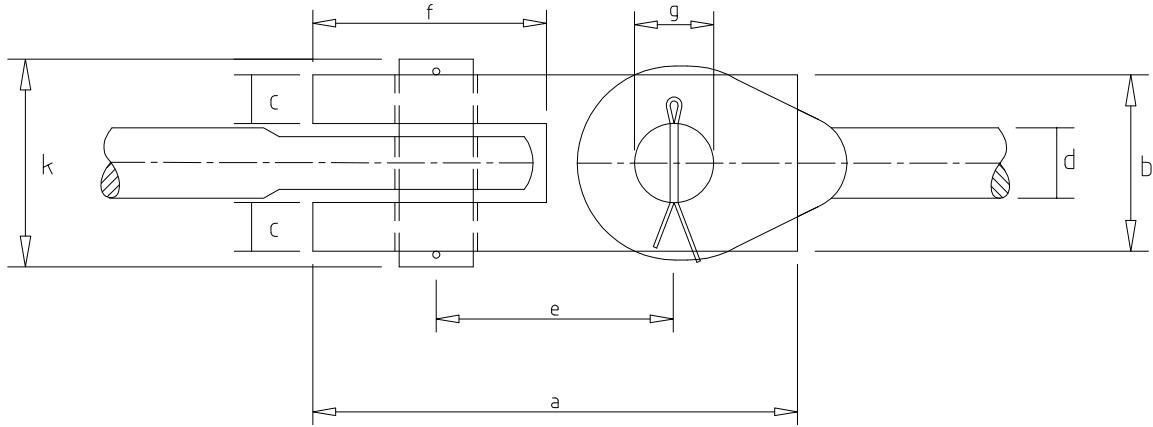

	A300B	A325	A350	A375A	A375B	A400	A425	A450	A450	A475	A500	A525	A550	A575	A575	A600	A625	A650
	M76	M80	M85	M90	M95	M100	M105	M110	M115	M120	M125	M130	M135	M140	M145	M150	M155	M160
	405	425	435	475	500	545	580	615	615	655	680	705	740	785	785	815	860	890
	170	180	190	200	210	220	230	250	250	270	280	290	300	320	320	330	350	360
	27	28	30	32	34	36	37	40	40	42	44	46	48	52	52	55	57	58
	220	230	230	255	265	295	320	330	330	355	365	380	400	415	415	430	460	470
	189	199	203	222	233	255	272	288	288	307	318	330	346	367	367	380	402	416
	65	68	73	77	82	87	91	99	99	104	108	113	118	126	126	131	136	141
	150	160	165	175	185	195	200	215	215	225	235	245	255	270	270	280	290	300

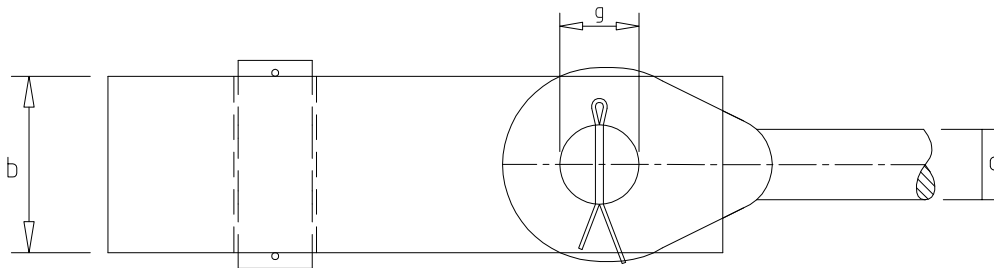

	A300B	A325	A350	A375A	A375B	A400	A425	A450	A450	A475	A500	A525	A550	A575	A575	A600	A625	A650
	M76	M80	M85	M90	M95	M100	M105	M110	M115	M120	M125	M130	M135	M140	M145	M150	M155	M160
	170	180	190	200	210	220	230	250	250	270	280	290	300	320	320	330	350	360
	27	28	30	32	34	36	37	40	40	42	44	46	48	52	52	55	57	58
	189	199	203	222	233	255	272	288	288	307	318	330	346	367	367	380	402	416
	65	68	73	77	82	87	91	99	99	104	108	113	118	126	126	131	136	141
	150	160	165	175	185	195	200	215	215	225	235	245	255	270	270	280	290	300

**T-Connection**

ASF355 - ASF500 - ASF720

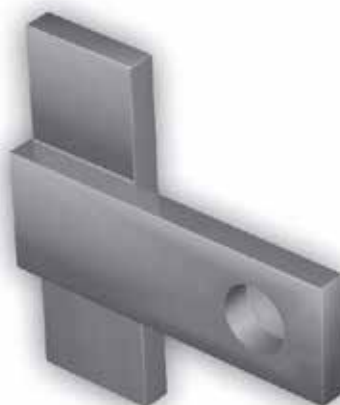

ASF355-Anchor force to DIN EN 1993-5 - kt 0,6			A150	A175	A200	A200	A225	A225	A225	A250	A275	A300A
			M39	M42	M45	M48	M52	M56	M60	M64	M68	M72
Width, longitudinal plate	<b>b1</b>	<b>mm</b>	80	90	100	100	110	110	110	130	140	150
Thickness, longitudinal plate	<b>t1</b>	<b>mm</b>	15	15	20	20	20	20	20	25	25	25
Length, transverse plate	<b>l2</b>	<b>mm</b>	200	230	250	250	280	280	280	330	350	380
Width, transverse plate	<b>b2</b>	<b>mm</b>	80	90	100	100	110	110	110	130	140	150
Thickness, transverse plate	<b>t2</b>	<b>mm</b>	10	10	10	10	15	15	15	15	15	15
Hole diameter	<b>D</b>	<b>mm</b>	32	35	38	38	42	42	42	49	54	58
Hole spacing	<b>e</b>	<b>mm</b>	55	60	65	65	70	70	70	80	90	95

ASF500-Anchor force to DIN EN 1993-5 - kt 0,6			A150	A175	A200	A200	A225	A225	A225	A250	A275	A300A
			M39	M42	M45	M48	M52	M56	M60	M64	M68	M72
Width, longitudinal plate	<b>b1</b>	<b>mm</b>	80	90	100	100	110	110	110	130	140	150
Thickness, longitudinal plate	<b>t1</b>	<b>mm</b>	15	20	20	20	25	25	25	25	30	30
Length, transverse plate	<b>l2</b>	<b>mm</b>	200	230	250	250	280	280	280	330	350	380
Width, transverse plate	<b>b2</b>	<b>mm</b>	80	90	100	100	110	110	110	130	140	150
Thickness, transverse plate	<b>t2</b>	<b>mm</b>	10	10	15	15	15	15	15	20	20	20
Hole diameter	<b>D</b>	<b>mm</b>	32	35	38	38	43	43	43	49	54	58
Hole spacing	<b>e</b>	<b>mm</b>	55	60	65	65	70	70	70	80	90	95

ASF720-Anchor force to DIN EN 1993-5 - kt 0,6			A150	A175	A200	A200	A225	A225	A225	A250	A275	A300A
			M39	M42	M45	M48	M52	M56	M60	M64	M68	M72
Width, longitudinal plate	<b>b1</b>	<b>mm</b>	80	90	110	110	120	120	120	130	150	160
Thickness, longitudinal plate	<b>t1</b>	<b>mm</b>	20	20	25	25	25	25	25	30	35	35
Length, transverse plate	<b>l2</b>	<b>mm</b>	200	230	280	280	300	300	300	330	380	400
Width, transverse plate	<b>b2</b>	<b>mm</b>	80	90	110	110	120	120	120	130	150	160
Thickness, transverse plate	<b>t2</b>	<b>mm</b>	10	15	15	15	20	20	20	20	20	25
Hole diameter	<b>D</b>	<b>mm</b>	32	35	42	42	46	46	46	52	57	63
Hole spacing	<b>e</b>	<b>mm</b>	55	60	70	70	75	75	75	85	95	105

# 7

## CONNECTION ELEMENTS EYE ANCHOR

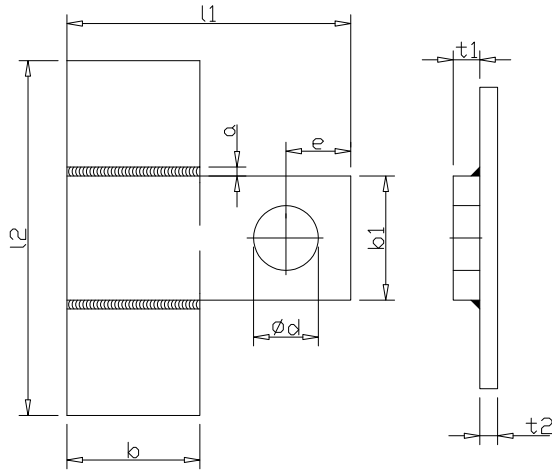

	A300B	A325	A350	A375A	A375B	A400	A425	A450	A450	A475	A500	A525	A550	A575	A575	A600	A625	A650
	M76	M80	M85	M90	M95	M100	M105	M110	M115	M120	M125	M130	M135	M140	M145	M150	M155	M160
	150	160	180	180	180	200	210	220	220	230	250	260	260	270	270	280	300	310
	30	30	35	35	35	40	40	45	45	45	50	50	50	55	55	55	60	60
	380	400	450	450	450	500	530	550	550	580	630	650	650	680	680	700	750	780
	150	160	180	180	180	200	210	220	220	230	250	260	260	270	270	280	300	310
	15	20	20	20	20	20	25	25	25	25	30	30	30	35	35	35	35	35
	58	64	70	72	72	78	82	87	87	92	97	102	102	107	107	112	117	122
	95	105	115	120	120	125	135	140	140	150	160	165	165	175	175	180	190	200

	A300B	A325	A350	A375A	A375B	A400	A425	A450	A450	A475	A500	A525	A550	A575	A575	A600	A625	A650
	M76	M80	M85	M90	M95	M100	M105	M110	M115	M120	M125	M130	M135	M140	M145	M150	M155	M160
	150	160	180	180	180	200	210	220	220	230	250	260	270	280	280	300	310	320
	35	35	40	40	45	45	50	50	50	55	55	60	60	65	65	65	70	70
	380	400	450	450	450	500	530	550	550	580	630	650	680	700	700	750	780	800
	150	160	180	180	180	200	210	220	220	230	250	260	270	280	280	300	310	320
	25	25	25	25	30	30	30	35	35	35	40	40	40	45	45	45	45	50
	58	64	70	72	72	78	82	87	87	92	97	102	107	112	112	117	122	127
	95	105	115	120	120	125	135	140	140	150	160	165	175	180	180	190	200	205

	A300B	A325	A350	A375A	A375B	A400	A425	A450	A450	A475	A500	A525	A550	A575	A575	A600	A625	A650
	M76	M80	M85	M90	M95	M100	M105	M110	M115	M120	M125	M130	M135	M140	M145	M150	M155	M160
	160	170	190	200	200	220	230	250	250	260	270	280	280	300	300	320	330	350
	40	40	45	45	45	50	55	55	55	60	65	65	65	70	70	75	75	80
	400	430	480	500	500	550	580	630	630	650	680	700	700	750	750	800	830	880
	160	170	190	200	200	220	230	250	250	260	270	280	280	300	300	320	330	350
	25	30	30	30	30	35	35	40	40	40	45	45	50	50	50	50	55	55
	63	68	74	78	78	87	92	97	97	102	107	112	112	117	117	127	132	137
	105	110	120	125	125	140	150	160	160	165	175	180	180	190	190	205	215	220

**Double T-Connection**

ASF355 - ASF500 - ASF720

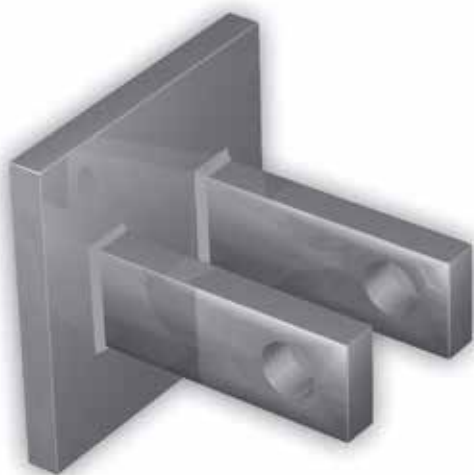

ASF355-Anchor force to DIN EN 1993-5 - kt 0,6			A150	A175	A200	A200	A225	A225	A225	A250	A275	A300A
			M39	M42	M45	M48	M52	M56	M60	M64	M68	M72
Width, longitudinal plate	<b>b1</b>	<b>mm</b>	80	90	100	100	110	110	110	130	140	150
Thickness, longitudinal plate	<b>t1</b>	<b>mm</b>	15	15	20	20	20	20	20	25	25	25
Length, transverse plate	<b>b2</b>	<b>mm</b>	120	140	160	160	180	180	180	210	220	240
Length, transverse plate	<b>l2</b>	<b>mm</b>	120	140	160	160	180	180	180	210	220	240
Thickness, transverse plate	<b>t2</b>	<b>mm</b>	15	20	25	25	30	30	30	35	35	40
Hole diameter	<b>D1</b>	<b>mm</b>	32	35	38	38	42	42	42	49	54	58
Hole spacing	<b>e</b>	<b>mm</b>	55	60	65	65	70	70	70	80	90	95

ASF500-Anchor force to DIN EN 1993-5 - kt 0,6			A150	A175	A200	A200	A225	A225	A225	A250	A275	A300A
			M39	M42	M45	M48	M52	M56	M60	M64	M68	M72
Width, longitudinal plate	<b>b1</b>	<b>mm</b>	80	90	100	100	110	110	110	130	140	150
Thickness, longitudinal plate	<b>t1</b>	<b>mm</b>	15	20	20	20	25	25	25	25	30	30
Length, transverse plate	<b>b2</b>	<b>mm</b>	130	160	170	170	210	210	210	230	250	270
Length, transverse plate	<b>l2</b>	<b>mm</b>	130	160	170	170	210	210	210	230	250	270
Thickness, transverse plate	<b>t2</b>	<b>mm</b>	20	20	25	25	30	30	30	40	40	45
Hole diameter	<b>D1</b>	<b>mm</b>	32	35	38	38	43	43	43	49	54	58
Hole spacing	<b>e</b>	<b>mm</b>	55	60	65	65	70	70	70	80	90	95

ASF720-Anchor force to DIN EN 1993-5 - kt 0,6			A150	A175	A200	A200	A225	A225	A225	A250	A275	A300A
			M39	M42	M45	M48	M52	M56	M60	M64	M68	M72
Width, longitudinal plate	<b>b1</b>	<b>mm</b>	80	90	110	110	120	120	120	130	150	160
Thickness, longitudinal plate	<b>t1</b>	<b>mm</b>	20	20	25	25	25	25	25	30	35	35
Length, transverse plate	<b>b2</b>	<b>mm</b>	150	170	200	200	230	230	230	260	280	320
Length, transverse plate	<b>l2</b>	<b>mm</b>	150	170	200	200	230	230	230	260	280	320
Thickness, transverse plate	<b>t2</b>	<b>mm</b>	20	25	30	30	35	35	35	40	45	55
Hole diameter	<b>D1</b>	<b>mm</b>	32	35	42	42	46	46	46	52	57	63
Hole spacing	<b>e</b>	<b>mm</b>	55	60	70	70	75	75	75	85	95	105

# 7

## CONNECTION ELEMENTS EYE ANCHOR

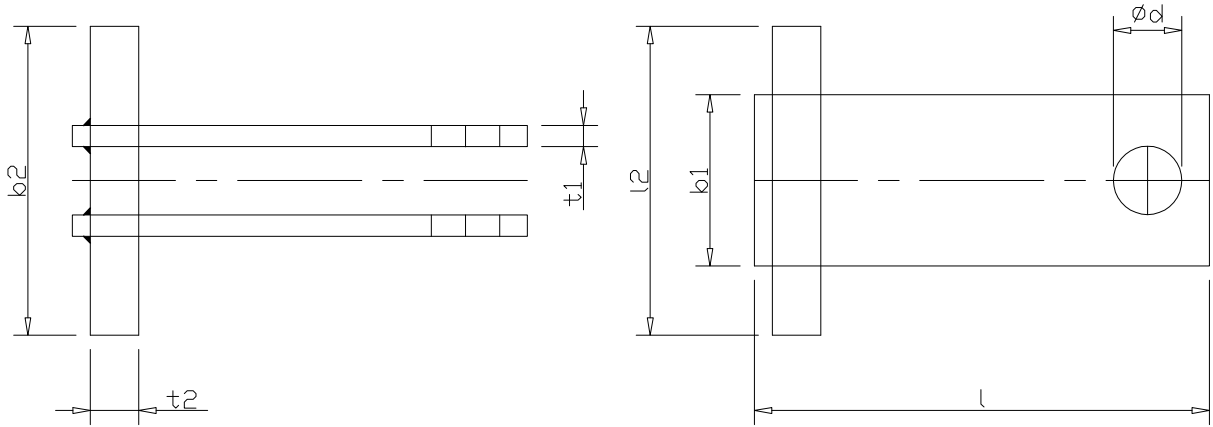

	A300B	A325	A350	A375A	A375B	A400	A425	A450	A450	A475	A500	A525	A550	A575	A575	A600	A625	A650
	M76	M80	M85	M90	M95	M100	M105	M110	M115	M120	M125	M130	M135	M140	M145	M150	M155	M160
	150	160	180	180	180	200	210	220	220	230	250	260	260	270	270	280	300	310
	30	30	35	35	35	40	40	45	45	45	50	50	50	55	55	55	60	60
	250	270	290	300	310	330	350	370	370	390	420	440	450	470	470	490	520	530
	250	270	290	300	310	330	350	370	370	390	420	440	450	470	470	490	520	530
	40	45	50	50	50	55	60	60	60	65	70	75	75	75	75	80	85	90
	58	64	70	72	72	78	82	87	87	92	97	102	102	107	107	112	117	122
	95	105	115	120	120	125	135	140	140	150	160	165	165	175	175	180	190	200

	A300B	A325	A350	A375A	A375B	A400	A425	A450	A450	A475	A500	A525	A550	A575	A575	A600	A625	A650
	M76	M80	M85	M90	M95	M100	M105	M110	M115	M120	M125	M130	M135	M140	M145	M150	M155	M160
	150	160	180	180	180	200	210	220	220	230	250	260	270	280	280	300	310	320
	35	35	40	40	45	45	50	50	50	55	55	60	60	65	65	65	70	70
	290	310	330	340	360	380	410	430	430	450	480	500	510	530	530	560	590	610
	290	310	330	340	360	380	410	430	430	450	480	500	510	530	530	560	590	610
	45	50	55	55	55	60	65	70	70	70	80	80	85	85	85	95	95	100
	58	64	70	72	72	78	82	87	87	92	97	102	107	112	112	117	122	127
	95	105	115	120	120	125	135	140	140	150	160	165	175	180	180	190	200	205

	A300B	A325	A350	A375A	A375B	A400	A425	A450	A450	A475	A500	A525	A550	A575	A575	A600	A625	A650
	M76	M80	M85	M90	M95	M100	M105	M110	M115	M120	M125	M130	M135	M140	M145	M150	M155	M160
	160	170	190	200	200	220	230	250	250	260	270	280	280	300	300	320	330	350
	40	40	45	45	45	50	55	55	55	60	65	65	65	70	70	75	75	80
	320	340	370	390	390	420	450	480	480	500	530	550	560	590	590	620	650	670
	320	340	370	390	390	420	450	480	480	500	530	550	560	590	590	620	650	670
	50	55	60	65	65	70	75	80	80	85	85	90	95	100	100	105	110	115
	63	68	74	78	78	87	92	97	97	102	107	112	112	117	117	127	132	137
	105	110	120	125	125	140	150	160	160	165	175	180	180	190	190	205	215	220

**Anchor Box**  
ASF355 - ASF500

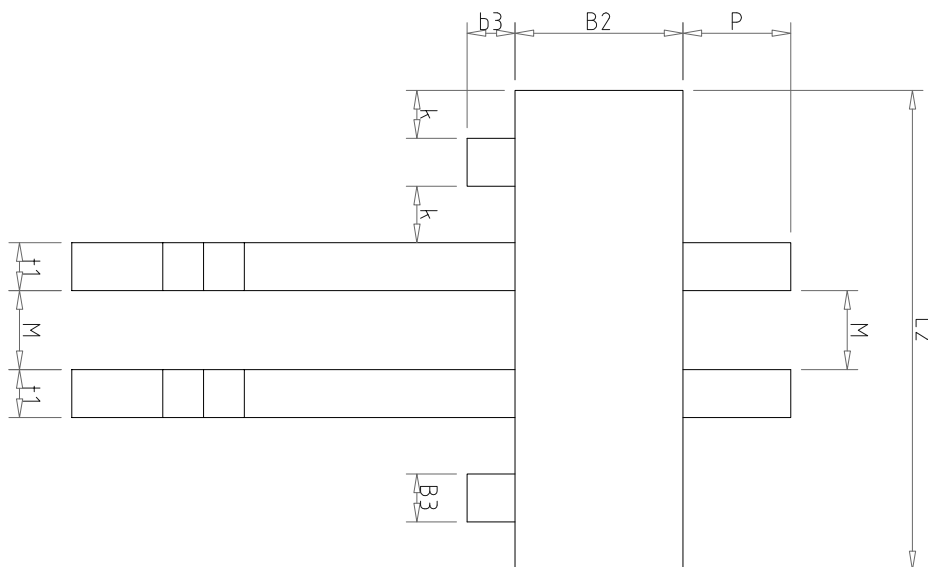

ASF355-Anchor force to DIN EN 1993-5 - kt 0,6			A150	A175	A200	A200	A225	A225	A225	A250	A275	A300A
			M39	M42	M45	M48	M52	M56	M60	M64	M68	M72
Length plate 1	L1	mm	250	280	300	300	330	330	330	370	390	420
Width plate 1	B1	mm	80	90	100	100	110	110	110	130	140	150
Thickness plate 1	t1	mm	15	15	20	20	20	20	20	25	25	25
Length plate 2	L2	mm	180	180	210	210	210	210	210	230	240	240
Width plate 2	B2	mm	50	60	70	70	70	70	70	80	80	90
Thickness plate 2	t2	mm	10	15	15	15	20	20	20	20	25	25
Length strut	L3	mm	110	120	140	140	150	150	150	180	190	200
Width strut	t3	mm	15	15	20	20	20	20	20	25	25	25
Height strut	B3	mm	15	15	20	20	20	20	20	25	25	25
Length	P	mm	25	35	35	35	50	50	50	50	55	60
Hole diameter	d0	mm	32	35	38	38	42	42	42	49	54	58
Hole spacing	a	mm	36	39	42	42	47	47	47	54	60	64
Spacing	K	mm	20	20	20	20	20	20	20	20	20	20
Spacing between plate 1	M	mm	33	38	41	41	47	47	47	50	55	58

ASF500-Anchor force to DIN EN 1993-5 - kt 0,6			A150	A175	A200	A200	A225	A225	A225	A250	A275	A300A
			M39	M42	M45	M48	M52	M56	M60	M64	M68	M72
Length plate 1	L1	mm	250	290	310	310	350	350	350	380	420	440
Width plate 1	B1	mm	80	90	100	100	110	110	110	130	140	150
Thickness plate 1	t1	mm	15	20	20	20	25	25	25	25	30	30
Length plate 2	L2	mm	180	200	210	210	230	230	230	230	260	260
Width plate 2	B2	mm	50	70	70	70	80	80	80	80	100	100
Thickness plate 2	t2	mm	15	15	20	20	25	25	25	30	25	30
Length strut	L3	mm	110	130	140	140	160	160	160	180	200	210
Width strut	t3	mm	15	20	20	20	25	25	25	25	30	30
Height strut	B3	mm	15	20	20	20	25	25	25	25	30	30
Length	P	mm	30	35	45	45	55	55	55	65	60	70
Hole diameter	d0	mm	32	35	38	38	43	43	43	49	54	58
Hole spacing	a	mm	36	39	42	42	48	48	48	54	60	64
Spacing	K	mm	20	20	20	20	20	20	20	20	20	20
Spacing between plate 1	M	mm	33	38	41	41	47	47	47	50	55	58

# 7

## CONNECTION ELEMENTS EYE ANCHOR

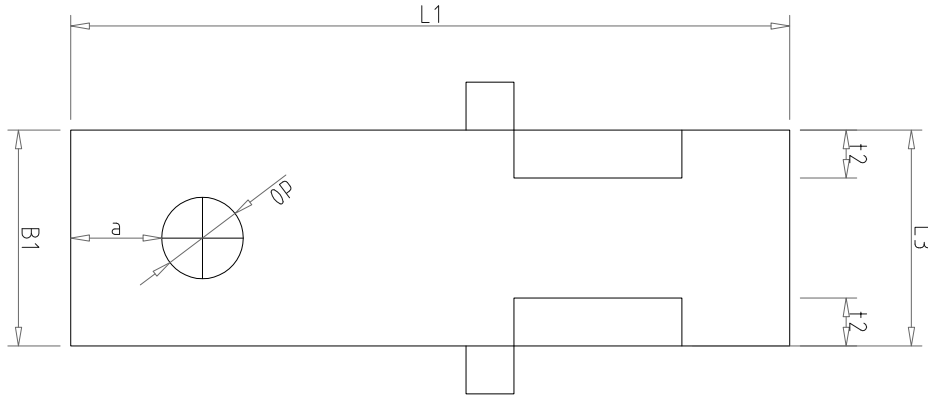

	A300B	A325	A350	A375A	A375B	A400	A425	A450	A450	A475	A500	A525	A550	A575	A575	A600	A625	A650
	M76	M80	M85	M90	M95	M100	M105	M110	M115	M120	M125	M130	M135	M140	M145	M150	M155	M160
	430	450	480	510	510	550	570	600	600	630	660	690	700	740	740	760	790	820
	150	160	180	180	180	200	210	220	220	230	250	260	260	270	270	280	300	310
	30	30	30	35	35	40	40	40	40	45	50	50	50	55	55	55	60	60
	260	270	270	300	300	320	320	330	330	350	380	380	390	410	410	420	450	450
	100	90	90	110	110	120	120	120	120	130	140	140	140	160	160	160	170	170
	25	30	35	30	35	35	40	45	45	45	45	50	55	55	55	55	55	60
	210	220	240	250	250	280	290	300	300	320	350	360	360	380	380	390	420	430
	30	30	30	35	35	40	40	40	40	45	50	50	50	55	55	55	60	60
	30	30	30	35	35	40	40	40	40	45	50	50	50	55	55	55	60	60
	60	70	80	75	80	85	95	105	105	105	105	115	125	125	125	135	135	145
	58	64	70	72	72	78	82	87	87	92	97	102	102	107	107	112	117	122
	64	71	77	80	80	86	91	96	96	102	107	113	113	118	118	124	129	135
	20	20	20	20	20	20	20	20	20	20	20	20	20	20	20	20	20	20
	58	63	68	71	71	74	80	83	83	88	93	98	103	108	108	113	123	128

	A300B	A325	A350	A375A	A375B	A400	A425	A450	A450	A475	A500	A525	A550	A575	A575	A600	A625	A650
	M76	M80	M85	M90	M95	M100	M105	M110	M115	M120	M125	M130	M135	M140	M145	M150	M155	M160
	460	480	520	540	550	580	620	650	650	680	710	740	770	800	800	820	870	900
	150	160	180	180	180	200	210	220	220	230	250	260	270	280	280	300	310	320
	35	35	40	40	40	45	50	50	50	55	55	60	60	65	65	65	70	70
	280	290	310	320	320	340	360	370	370	390	400	420	430	450	450	460	490	490
	110	110	120	120	120	130	150	150	150	160	160	170	170	180	180	180	200	200
	30	35	35	40	45	45	45	50	50	50	55	55	60	60	60	65	65	70
	220	230	260	260	260	290	310	320	320	340	360	380	390	410	410	430	450	460
	35	35	40	40	40	45	50	50	50	55	55	60	60	65	65	65	70	70
	35	35	40	40	40	45	50	50	50	55	55	60	60	65	65	65	70	70
	70	80	80	95	100	100	105	115	115	115	130	130	140	140	140	150	155	165
	58	64	70	72	72	78	82	87	87	92	97	102	107	112	112	117	122	127
	64	71	77	80	80	86	91	96	96	102	107	113	118	124	124	129	135	140
	20	20	20	20	20	20	20	20	20	20	20	20	20	20	20	20	20	20
	58	63	68	71	71	74	80	83	83	88	93	98	103	108	108	113	123	128

**Anchor Box**  
ASF720

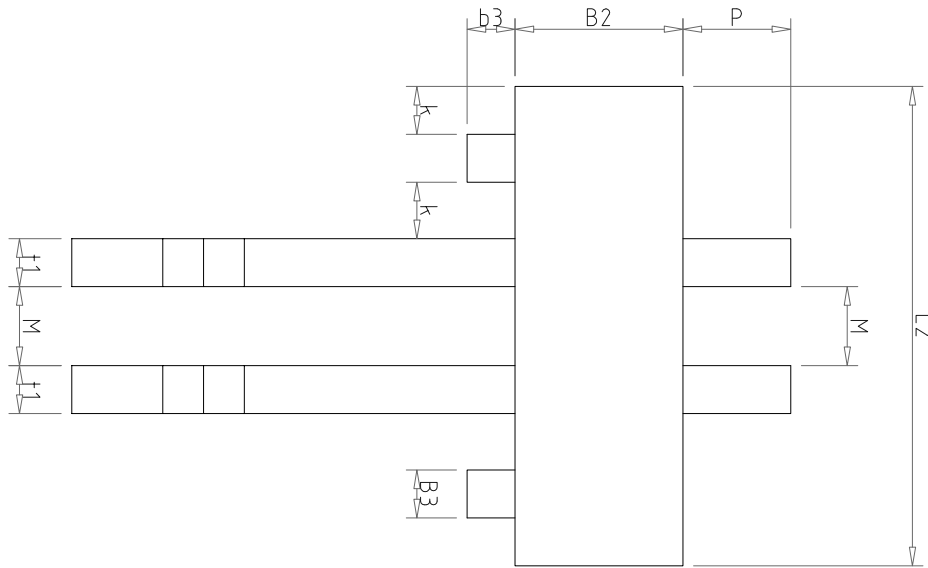

ASF720-Anchor force to DIN EN 1993-5 - kt 0,6			A150	A175	A200	A200	A225	A225	A225	A250	A275	A300A
			M39	M42	M45	M48	M52	M56	M60	M64	M68	M72
Length plate 1	L1	mm	280	300	340	340	380	380	380	420	450	490
Width plate 1	B1	mm	80	90	110	110	120	120	120	130	150	160
Thickness plate 1	t1	mm	20	20	25	25	25	25	25	30	35	35
Length plate 2	L2	mm	200	200	230	230	230	230	230	250	280	280
Width plate 2	B2	mm	70	70	80	80	90	90	90	100	110	110
Thickness plate 2	t2	mm	15	20	20	20	25	25	25	30	30	40
Length strut	L3	mm	120	130	160	160	170	170	170	190	220	230
Width strut	t3	mm	20	20	25	25	25	25	25	30	35	35
Height strut	B3	mm	20	20	25	25	25	25	25	30	35	35
Length	P	mm	30	45	45	45	60	60	60	70	70	90
Hole diameter	d0	mm	32	35	42	42	46	46	46	52	57	63
Hole spacing	a	mm	36	39	47	47	51	51	51	58	63	70
Spacing	K	mm	20	20	20	20	20	20	20	20	20	20
Spacing between plate 1	M	mm	33	38	41	41	47	47	47	50	55	58



# 7

## CONNECTION ELEMENTS EYE ANCHOR

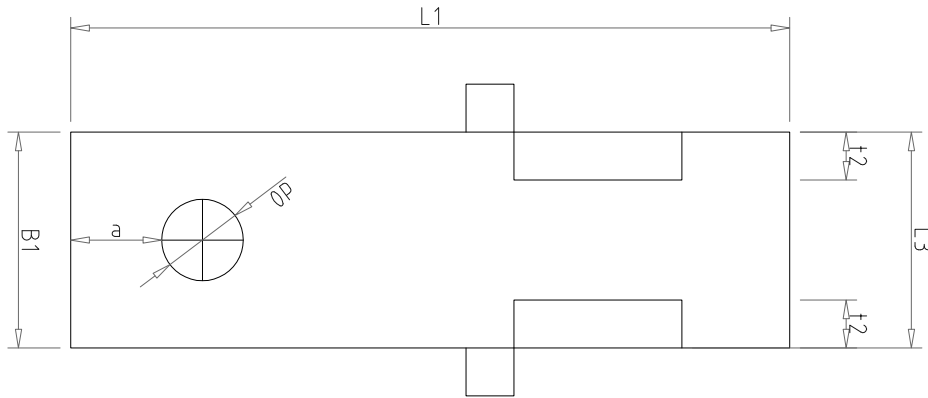

	A300B	A325	A350	A375A	A375B	A400	A425	A450	A450	A475	A500	A525	A550	A575	A575	A600	A625	A650
	M76	M80	M85	M90	M95	M100	M105	M110	M115	M120	M125	M130	M135	M140	M145	M150	M155	M160
	500	530	570	590	590	630	680	710	710	750	780	810	810	840	840	910	940	980
	160	170	190	200	200	220	230	25	250	260	270	280	280	300	300	320	330	350
	40	40	45	45	45	50	55	55	55	60	65	65	65	70	70	75	75	80
	300	310	330	340	340	360	380	390	390	410	440	440	450	470	470	500	510	530
	120	120	130	130	130	140	160	160	160	170	180	180	180	190	190	210	210	220
	35	40	45	50	50	50	50	55	55	60	60	65	70	70	70	70	75	80
	240	250	280	290	290	320	340	360	360	380	400	410	410	440	440	470	480	510
	40	40	45	45	45	50	55	55	55	60	65	65	65	70	70	75	75	80
	40	40	45	45	45	50	55	55	55	60	65	65	65	70	70	75	75	80
	80	95	100	110	110	110	115	130	130	135	135	150	155	155	155	160	175	185
	63	68	74	78	78	87	92	97	97	102	107	112	112	117	117	127	132	137
	70	75	82	86	86	96	102	107	107	113	118	124	124	129	129	140	146	151
	20	20	20	20	20	20	20	20	20	20	20	20	20	20	20	20	20	20
	58	63	68	71	71	74	80	83	83	88	93	98	103	108	108	113	123	128



## An innovative anchor that sets standards

**Horizontal round steel tie rods generally represent the most cost-effective anchorage solution. However, if particular boundary conditions, e.g. structures nearby, unsuitable soils just below ground level or refurbishment work on existing structures, mean that horizontal anchors cannot be installed, then grouted anchors to DIN EN 14199 can be used.**

Such anchors can be installed in changing subsoil conditions and in various lengths and at various angles.

The anchor forces are carried via skin friction between the pile and the subsoil. In order to be able to assess the loadbearing behaviour of the piles, we recommend tension loading tests to DIN EN 14199 and „EA-Pfähle“ (Recommendations on Piling, German Geotechnical Society).

In contrast to round steel tie rods, it is not necessary to carry out any excavation work to install anchor piles. A hinge is to be preferred to fixity at the connection between sheet pile wall and head of anchor. Such a connection permits rotation, which compensates for deflection, settlement and installation conditions (see also EAU 2012).

Our grouted anchors can be fabricated with and without upset ends to DIN EN 1993-5 in lengths of up to 35 m. Furthermore, each pile can be extended to any length by welding or by using couplers. Yield stresses of min. 355 to max. 590 N/mm<sup>2</sup> can be guaranteed depending on the grade of steel.

In addition, any type of wall connection is possible, e.g. upset thread, eye rod or T-head joint.



**TK-ASF grouted anchors, despite their small diameter, make use of special pressure grouting methods to transfer extremely high service loads into the subsoil.**

**A National Technical Approval has been applied for (testing and certification by the German Institute of Building Technology, DIBt, Berlin). In addition, approval for a steel connection detail has been applied for.**

**Our grouted anchors can be supplied ex works in diameters of up to 6.5 inch and individual lengths of up to 35 m. Metric threads up to M160 can be supplied as an alternative.**

**They can be lengthened by welding or by using couplers to form any required length.**

#### Applications

- Anchorages in port and specialist civil engineering
- Tension and compression foundation piles
- Anchorages for canal upgrades/extensions

#### Advantages

- High internal load-carrying capacity
- Low deformation, high robustness owing to high loadbearing reserves
- Easily adapted to suit tried-and-tested connection details (anchor plates, turnbuckles, couplers, eye rods, universal joints, etc.)
- For use in cohesive and friable soils
- The simplicity of the design according to the acknowledged standards of steel hydraulic engineering makes it easier for engineers to specify this system in their tenders
- Designed for very high loads up to 7930 kN – up to 70% more than conventional piles
- Suitable for use as tension and compression piles to DIN EN 14199
- Low steel strain guarantees fast mobilisation of forces for small deformations
- The surrounding grout constitutes an alkaline environment for corrosion protection over the full length – which saves work and costs



Pile head/concrete connection detail

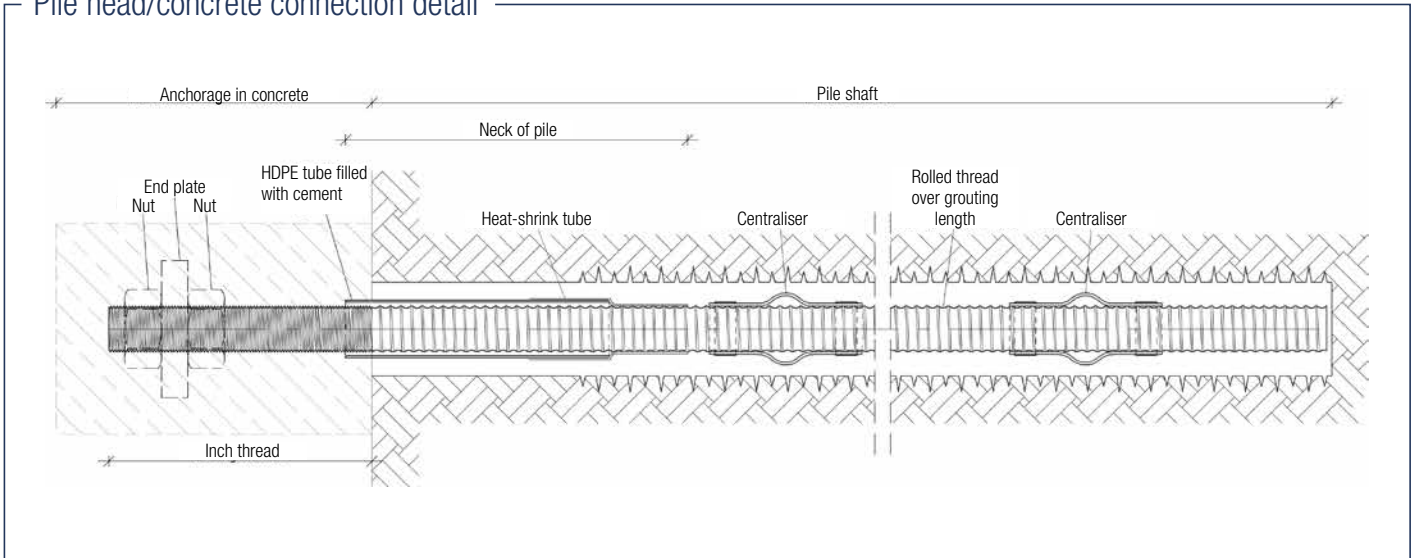

Permissible design resistance to EC7-1, section 7

Round steel tie rods (Whitworth thread) – steel grade ASF500/700

Nominal size		Zoll	2	2 ½	3*	3 ½*	4*	4 ¼*	4 ½*	5	5 ½	6
Diameter D		mm	50	63	75	90	100	110	115	125	140	150
	$\varnothing_{Kern}$	mm	42.9	54.7	66.2	78.1	90.0	95.8	102.2	114.4	126.5	138.8
	$\varnothing_{Flanke}$	mm	46.8	59.0	71.1	83.4	95.7	101.8	108.1	120.6	133.0	145.4
Thread	$A_{Span}$	cm <sup>2</sup>	15.8	25.4	37	51.3	67.7	76.7	86.9	108.4	132.2	158.6
Solid shaft, characteristic resistance	$R_{t,k}$	kN	790	1269	1851	2563	3385	3835	4344	5418	6609	7930
Solid shaft, design resistance	$R_{t,d}$	kN	687	1104	1609	2229	2943	3335	3777	4711	5747	6896
Weight		kg/m	16.6	21.5	31.1	42.5	56.8	64.1	71.9	90.3	109.1	129.6

\* National Technical Approval applied for

The design resistances are calculated using the critical stressed cross-section:

$$R_d = A_{Span} \times f_{y,k} / \gamma_M \quad \text{mit} \quad \gamma_M = 1,15$$

Cast-in pile head

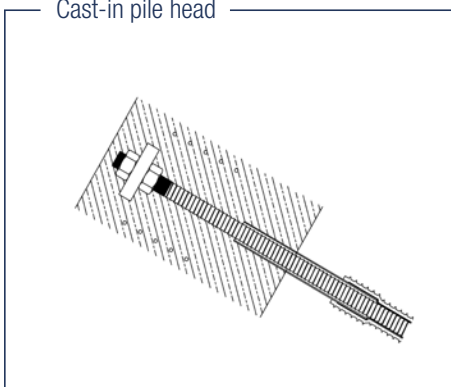

Pile head/RC connection detail

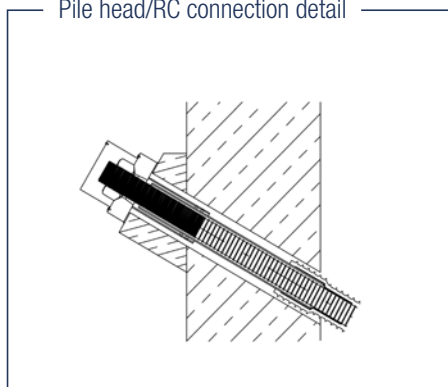

Pile head/steel connection

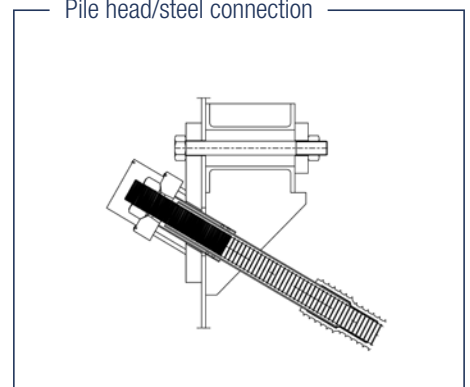

This product has been used successfully on the following structures so far

- Schwelgern harbour | 2016/2017
- HLT Duisburg | 2015
- EnBW Neckarwestheim | 2015
- Gernsheim port basin I | 2013
- Import Kohleumschlag Consortium / Bottrop Port | 2014
- Gernsheim port basin I / 2013
- 2nd lock, Zeltingen | 2011
- Riesa port – SBO GmbH | 2011
- Bonn port | 2010
- Frankfurt East Port – Hafen Frankfurt GmbH | 2010
- New south quay, Parallel Port, Duisburg | 2010
- Logistic operations, Marl – Infracor GmbH | 2009
- Mannheimer Wharf, Frankfurt – Hafen Frankfurt GmbH | 2008/2009
- Logport II, Duisburg – Duisburger Hafen AG | 2008/2009
- Gustavsburg tank farm, Wesel – TanQuit | 2088/2009
- Outfall structure, Neuss Port | 2008
- Ship loading /unloading facility, Coelln-Neuessen Port – RAG | 2007/2008
- Kaiserwörth Port, Ludwigshafen | 2007
- KruppMannesmann steelworks port | 2007
- Logport I, Duisburg-Rheinhausen – Duisburger Hafen AG | 2007
- West breakwater, Wesel-Datteln Canal, Marl | 2005/2006
- Quay 4 + 5, Walsum Port – ThyssenKrupp Steel Europe AG | 2004/2005
- Nort Rhine quay, Duisburg | 2003/2004



**Walings transfer the forces from the sheet pile wall to the anchors and also stiffen and align the wall. Generally, walings are provided in the form of tension members on the inside of the main wall, but on anchor walls they are generally provided in the form of compression members at the rear of the wall.**

**EAU 2012 recommends providing sturdy walings with generous dimensions, with heavy walings made from S 235 material being preferred over lighter versions made from grade S 355.**

Owing to the risk of corrosion, structural weld seams must be at least 2 mm thicker than as required by the structural calculations.

The recommendation is to design the walings for the permissible anchor force of the anchor selected. Besides the horizontal loads due to anchor tension, line pull and forces due to imposed loads, walings must also carry vertical loads caused by the vertical anchor component, soil surcharges and self-weight. Horizontal longitudinal forces along the axis of the sheet pile wall, e.g. due to line pull, can also occur.



## Waling design

Normally, a waling is in the form of two latticed steel channels, positioned with their webs perpendicular to the sheet pile wall. Channel types UPE or UNP can be used as required. However, other steel sections such as single LARSEN sheet piles and I-sections or a capping beam solution are possible.

Reinforced concrete walings are used mainly in conjunction with anchor walls, apart from structures with anchor piles and when compensating for misalignments of sheet pile walls.

The necessary spacing between the two channel sections is achieved with further channel sections or web plates (so-called latticing) welded to the channels at intervals depending on the pile width. The spacing between the channels depends on the diameter and angle of the anchors, and must be large enough to ensure that the anchors do not touch the waling.

The channels of the waling will have to be strengthened where heavy-duty anchors are being used or where they are connected directly to the waling. Waling segments are supplied in lengths equal to a multiple of the anchor spacing. Waling splices should be positioned at points of minimum stress. A splice equal to the full cross-section is unnecessary but the splice must be capable of transferring the internal forces calculated.

Splice joints are generally in the form of bolted channel sections supplied with the necessary bolt holes ready to install. The waling sections are pre-drilled for the splice on one side of the joint only; the other side is drilled to suit on site. Welded joints do not need to be spliced provided they are staggered and fully connected in the manner of a structural steelwork connection.



## Fixing walings

**Each waling must be connected to the sheet pile wall (main wall) in such a way that the forces that occur can be properly transferred. In order to simplify erection and to accommodate vertical forces, the walings are supported on suitably designed, welded brackets. These brackets are generally made from sawn or torch-cut plate, but other forms are possible.**

Where the space beneath a waling is limited, a support suspended from the sheet pile wall is possible. The suspended supports are welded to the waling or connected to the washer plates for the waling bolts. Nevertheless, a suspended support still requires a short erection angle to be welded to the sheet pile wall below the waling.

An internal waling (tension waling) must be especially carefully connected to the sheet pile wall.

Sturdy waling bolts (min. M39) are necessary for transferring the horizontal forces to the waling and also for aligning the wall. Likewise, distributing forces due to a ship impact on a quay wall and allowing for the risk of corrosion call for generous dimensioning. Waling bolts must be sufficiently long if they are to be suitable for aligning the wall. We distinguish between bolts with an upset hexagonal head and studs with a thread at each end.

Waling bolts are positioned between the webs of the waling sections and transfer their loads via washer plates. We distinguish between the front plate in the trough of the sheet pile (which in the case of Z-piles is made in two parts because of the interlock in the middle of the flange of the pile) and the rear plate on the waling. For transferring longitudinal forces, the flanges of the waling can be bolted or welded to the back of the sheet pile wall (in contact with the soil). However, a cleat welded to the waling and braced against the webs of the sheet piles represents an alternative solution. On anchor walls, the connection is generally made to a waling behind the wall (compression waling). Waling fixings are not required for structural reasons; it is sufficient to support the waling on brackets.



Waling bracket

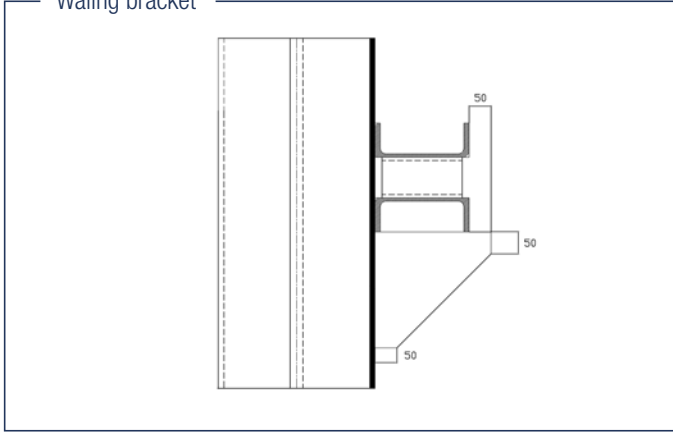

Suspended waling support

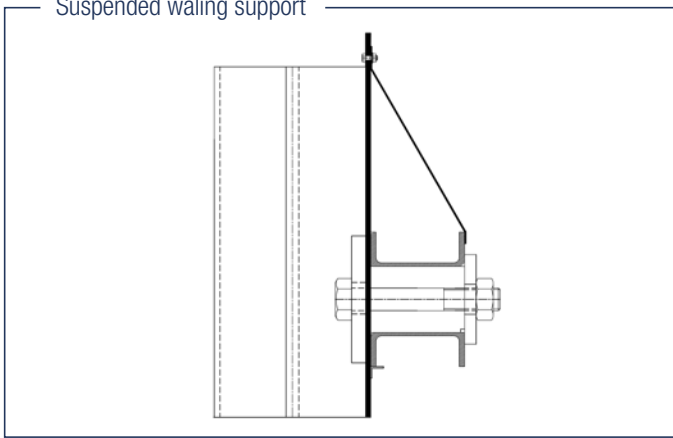

Fixing a waling made from a LARSEN pile

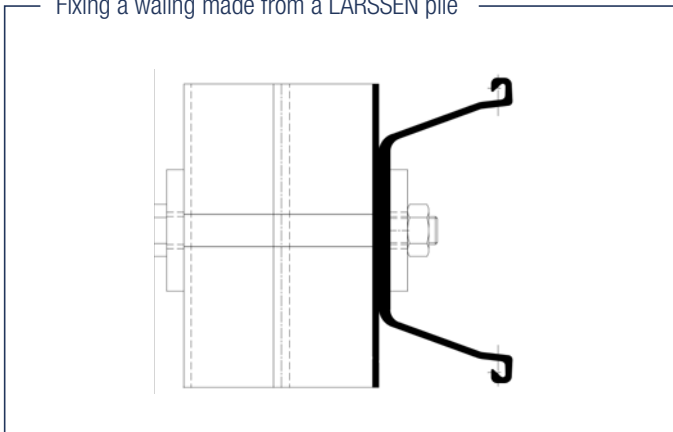

Standart waling fixing

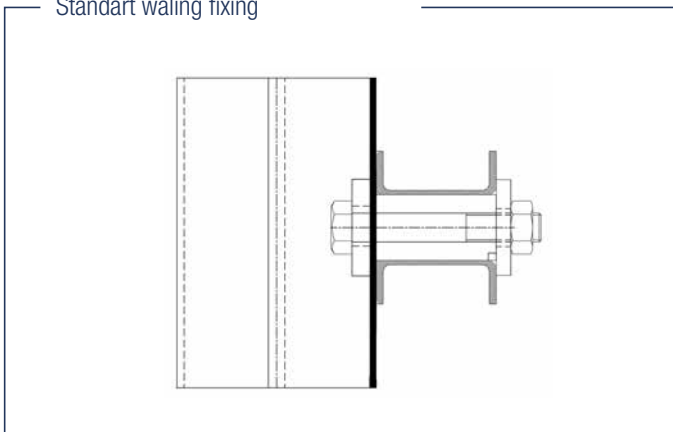

Cleats for transferring longitudinal forces

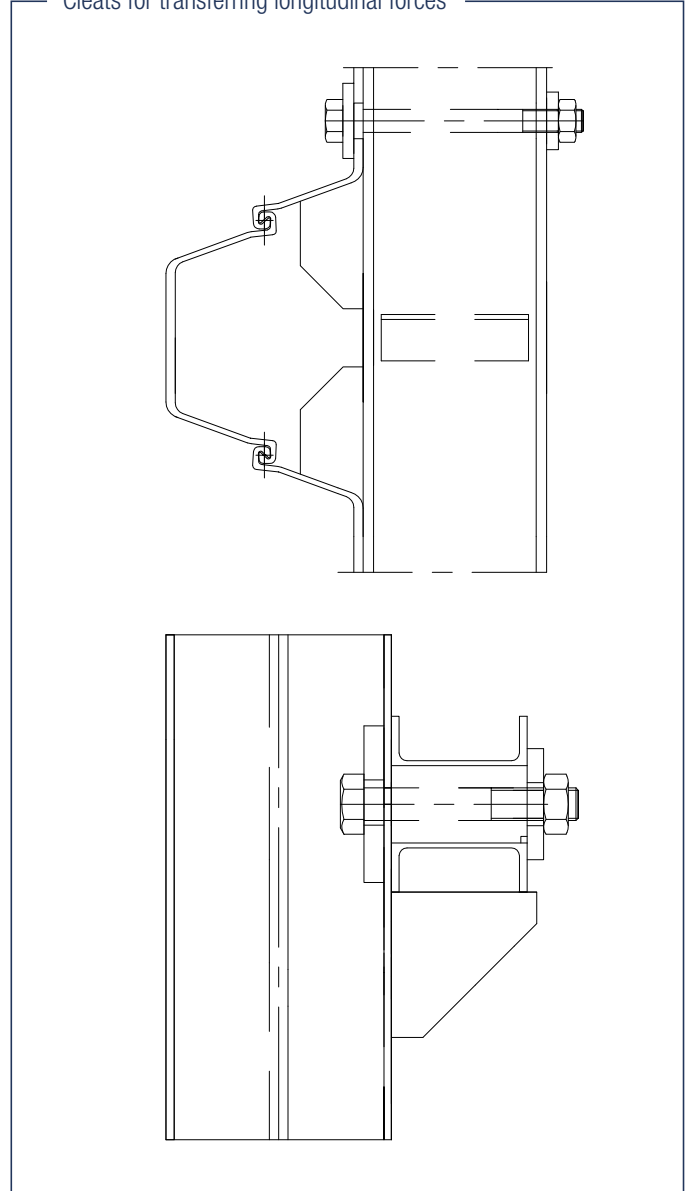

Typical connection to anchor wall

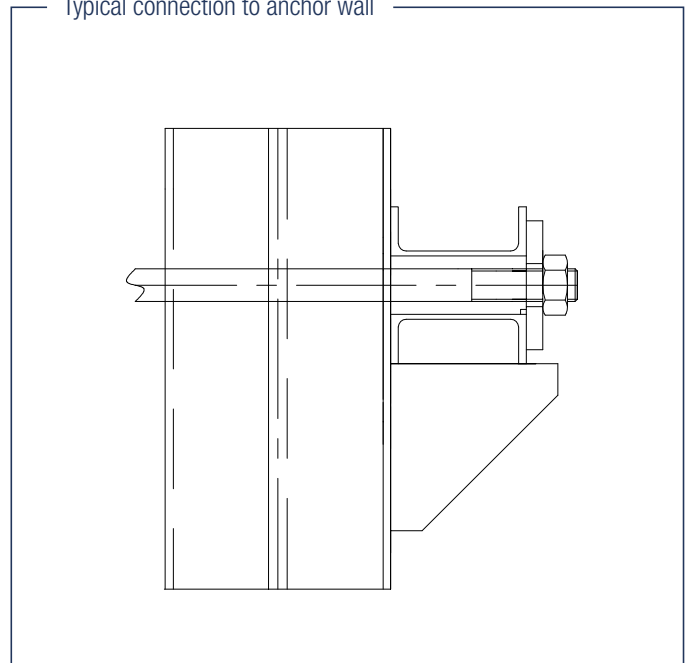

Waling splice joint

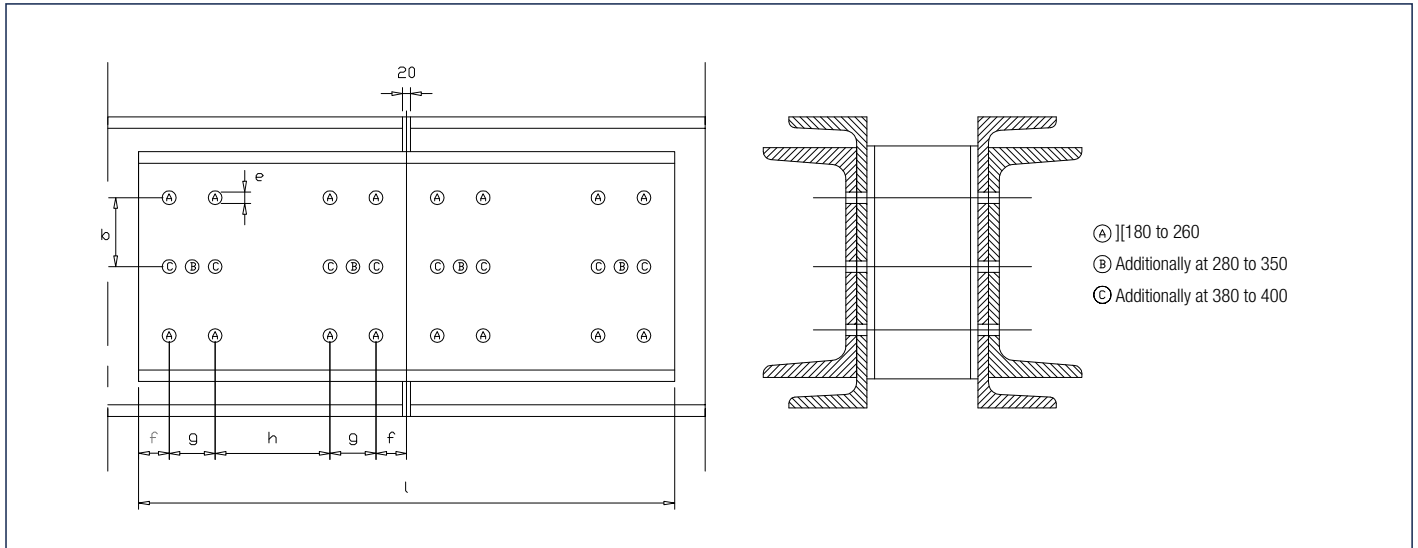

Waling UNP			Splicing peace UNP			Cut out	Dimension					Bolts DIN 7990 with washer DIN 7989	Nuts DIN	
][	Wy (cm <sup>3</sup> )	kg	][	i (mm)	kg		b (mm)	e∅ (mm)	f (mm)	g (mm)	h (mm)		SW (mm)	4032 kg/Satz
180	300	44.0	120	560	15.0	A	45	22	40	60	80	32 x M20 x 45 mm	30	8.0
200	382	50.6	140	640	20.5	A	60	22	40	60	120	32 x M20 x 45 mm	30	8.0
220	490	58.8	160	680	25.6	A	80	22	40	60	140	32 x M20 x 45 mm	30	8.0
240	600	66.4	180	740	32.6	A	90	26	50	75	120	32 x M24 x 50 mm	36	13.0
260	742	75.8	200	800	40.5	A	110	26	50	75	150	32 x M24 x 50 mm	36	13.0
280	896	83.6	220	840	49.4	AB	120	26	50	90	140	40 x M24 x 55 mm	36	16.0
300	1070	92.4	220	920	54.1	AB	120	26	50	90	180	40 x M24 x 55 mm	36	16.0
320	1358	119.0	240	1000	66.4	AB	130	32	60	110	160	40 x M30 x 65 mm	46	35.0
350	1468	121.2	260	1000	75.8	AB	140	32	60	110	160	40 x M30 x 65 mm	46	35.0
380	1658	126.2	300	1000	92.4	AC	180	32	60	90	200	48 x M30 x 65 mm	46	42.0
400	2036	143.6	300	1000	92.4	AC	180	32	60	90	200	48 x M30 x 65 mm	46	42.0



## Snuts

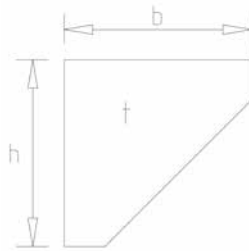

Waling section		][ 180	][ 200	][ 220	][ 240	][ 260	][ 280	][ 300	][ 320	][ 350	][ 380	][ 400
UNP												
h	(mm)	230	250	270	290	310	330	350	370	400	430	450
b	(mm)	230	250	270	290	310	330	350	370	400	430	450
t	(mm)	10	10	10	10	10	10	10	10	10	10	10
	(kg)	2.89	3.34	3.83	4.35	4.90	5.48	6.09	6.73	7.76	8.85	9.62

Waling section		][ 180	][ 200	][ 220	][ 240	][ 260	][ 280	][ 300	][ 320	][ 350	][ 380	][ 400
UNP												
h	(mm)	230	250	270	290	310	330	350	370	400	430	450
b	(mm)	230	250	270	290	310	330	350	370	400	430	450
t	(mm)	15	15	15	15	15	15	15	15	15	15	15
	(kg)	4.33	5.01	5.74	6.52	7.35	8.22	9.13	10.10	11.64	13.27	14.13

Waling section		][ 180	][ 200	][ 220	][ 240	][ 260	][ 280	][ 300	][ 320	][ 350	][ 380	][ 400
UNP												
h	(mm)	230	250	270	290	310	330	350	370	400	430	450
b	(mm)	230	250	270	290	310	330	350	370	400	430	450
t	(mm)	20	20	20	20	20	20	20	20	20	20	20
	(kg)	5.78	6.68	7.66	8.70	9.80	10.96	12.18	13.46	15.52	17.70	19.24

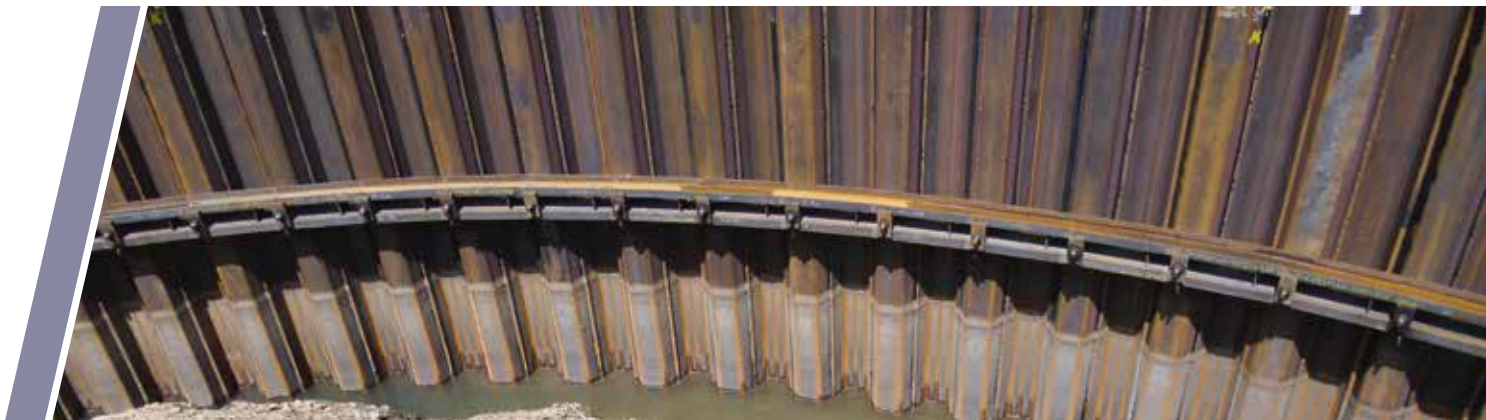

**Waling bolt with head and nut**

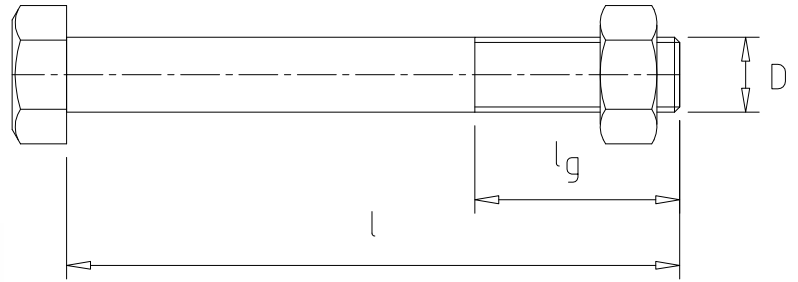

Dimension D	Metric	M27	M33	M39	M45	M52	M56	M64	M72	M76	M85	M90
][ 200	l (mm)	320	320	340	360							
	lg (mm)	85	95	105	115							
	kg	1.54	2.50	3.88	5.61							
][ 220	l (mm)	340	340	360	380	400						
	lg (mm)	85	95	105	115	125						
	kg	1.62	2.62	4.05	5.83	8.21						
][ 240	l (mm)	360	360	380	400	420	420	440	460			
	lg (mm)	85	95	105	115	125	130	135	140			
	kg	1.70	2.73	4.22	6.06	8.51	10.06	13.67	18.08			
][ 260	l (mm)	380	380	400	420	440	440	460	480	500	510	530
	lg (mm)	85	95	105	115	125	130	135	140	145	150	155
	kg	1.77	2.85	4.39	6.29	8.80	10.41	14.11	18.65	22.72	28.88	34.24
][ 280	l (mm)	400	400	420	440	460	460	480	500	520	540	570
	lg (mm)	85	95	105	115	125	130	135	140	145	150	155
	kg	1.85	2.97	4.56	6.52	9.10	10.76	14.56	19.23	23.36	29.69	35.16
][ 300	l (mm)		420	440	460	480	480	500	520	540	550	570
	lg (mm)		95	105	115	125	130	135	140	145	150	155
	kg		3.09	4.73	6.75	9.39	11.10	15.00	19.80	24.00	30.50	36.07
][ 320	l (mm)		440	460	480	500	500	520	540	560	570	590
	lg (mm)		95	105	115	125	130	135	140	145	150	155
	kg		3.21	4.89	6.97	9.69	11.45	15.44	20.32	24.64	31.31	36.98
][ 350	l (mm)			490	510	530	530	550	570	590	600	620
	lg (mm)			105	115	125	130	135	140	145	150	155
	kg			5.15	7.32	10.13	11.97	16.11	21.22	25.60	32.53	38.35
][ 380	l (mm)			520	540	560	560	580	600	620	630	650
	lg (mm)			105	115	125	130	135	140	145	150	155
	kg			5.40	7.66	10.58	12.49	16.78	22.08	26.56	33.74	39.72
][ 400	l (mm)			540	560	580	580	600	620	640	650	670
	lg (mm)			105	115	125	130	135	140	145	150	155
	kg			5.57	7.89	10.88	12.84	17.22	22.65	27.20	34.58	40.63

Steel grade: S355 / S355J2+N  
 The weight includes the nut  
 Also available in ASF 500 / 8.8 / 10.9

## Waling stud with two nuts



Dimension D	Metric	M27	M33	M39	M45	M52	M56	M64	M72	M76	M85	M90
][ 200	l (mm)	350	380	400	440							
	lg (mm)	85	95	105	115							
	kg	1.65	2.86	4.38	6.42							
][ 220	l (mm)	380	410	430	460	480						
	lg (mm)	85	95	105	115	125						
	kg	1.77	3.03	4.63	6.65	9.31						
][ 240	l (mm)	390	420	440	470	510	510	530	560	580	600	630
	lg (mm)	85	95	105	115	125	130	135	140	145	150	155
	kg	1.81	3.09	4.72	6.76	9.75	11.64	15.57	20.77	24.34	31.88	37.93
][ 260	l (mm)	410	440	460	490	530	530	550	580	600	620	650
	lg (mm)	85	95	105	115	125	130	135	140	145	150	155
	kg	1.88	3.21	4.89	6.99	10.05	11.98	16.01	21.34	24.98	32.68	38.84
][ 280	l (mm)	430	460	480	510	550	550	570	600	620	640	670
	lg (mm)	85	95	105	115	125	130	135	140	145	150	155
	kg	1.96	3.33	50.6	7.22	10.35	12.33	16.96	21.91	25.62	33.49	39.76
][ 300	l (mm)		480	510	540	570	570	600	620	640	660	690
	lg (mm)		95	105	115	125	130	135	140	145	150	155
	kg		3.45	5.31	7.56	10.64	12.68	17.12	22.48	26.26	34.8	40.67
][ 320	l (mm)			530	560	590	590	620	640	660	680	710
	lg (mm)			105	115	125	130	135	140	145	150	155
	kg			5.48	7.79	10.94	13.02	17.57	23.05	26.9	35.11	41.58
][ 350	l (mm)			550	580	620	620	640	660	680	710	740
	lg (mm)			105	115	125	130	135	140	145	150	155
	kg			5.65	8.02	11.38	13.54	18.01	23.62	27.54	36.33	42.95
][ 380	l (mm)			580	610	650	650	670	680	710	740	770
	lg (mm)			105	115	125	130	135	140	145	150	155
	kg			5.9	8.36	11.83	14.06	18.68	24.19	28.5	37.54	44.32
][ 400	l (mm)			600	630	670	670	690	700	730	760	790
	lg (mm)			105	115	125	130	135	140	145	150	155
	kg			6.07	8.59	12.12	14.41	19.12	24.76	29.14	38.35	45.23

Steel grade: S355 / S355J2+N

The weight includes the nut

Also available in ASF 500 / 8.8 / 10.9

## Sheet pile wall cappings

Permanent sheet pile wall structures are finished off at the top with a steel capping or reinforced concrete capping beam.

They are designed to suit constructional and operational criteria. However, structural considerations also play a role if the capping is required to transfer support reactions (capping beam). With adequate bending stiffness, a capping enables the top of the wall to be aligned, distributes operational loads and prevents uneven deflection of the top of the wall.

Steel cappings generally meet such requirements and are distinguished by their ease of installation.

The rolled or pressed „Union” capping with its distinctive „bulb” is commonly used. It provides a readily visible termination to the top of the sheet pile wall and prevents mooring ropes from being damaged by rubbing and scuffing. And with studs or serrations on the horizontal surfaces, this type of capping ensures a good non-slip surface. The „Union” capping is normally fixed to the sheet pile wall by welding it to a wide steel flat or bolting it to an angle. If the capping also functions as a waling, it must be designed in accordance with EAU 2012.

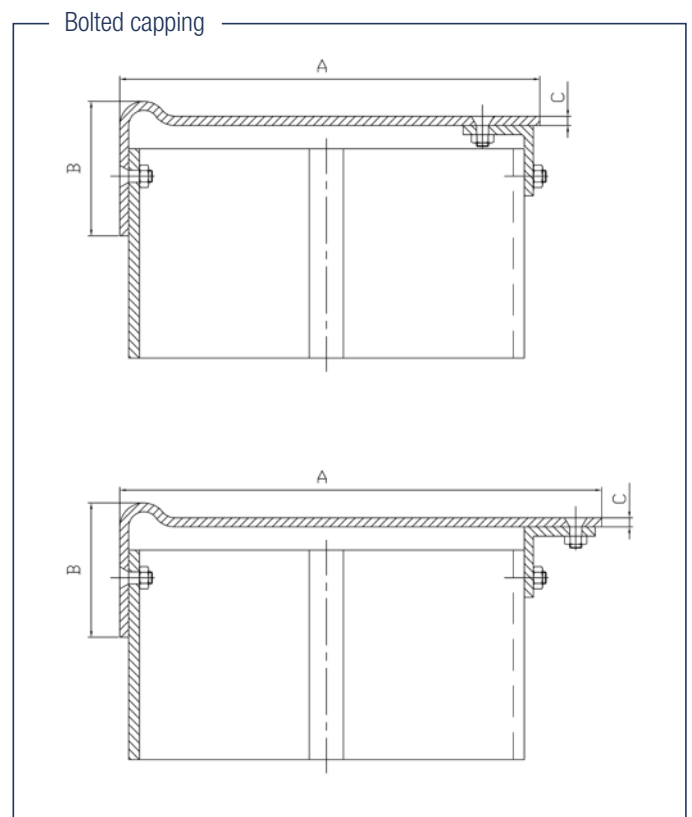
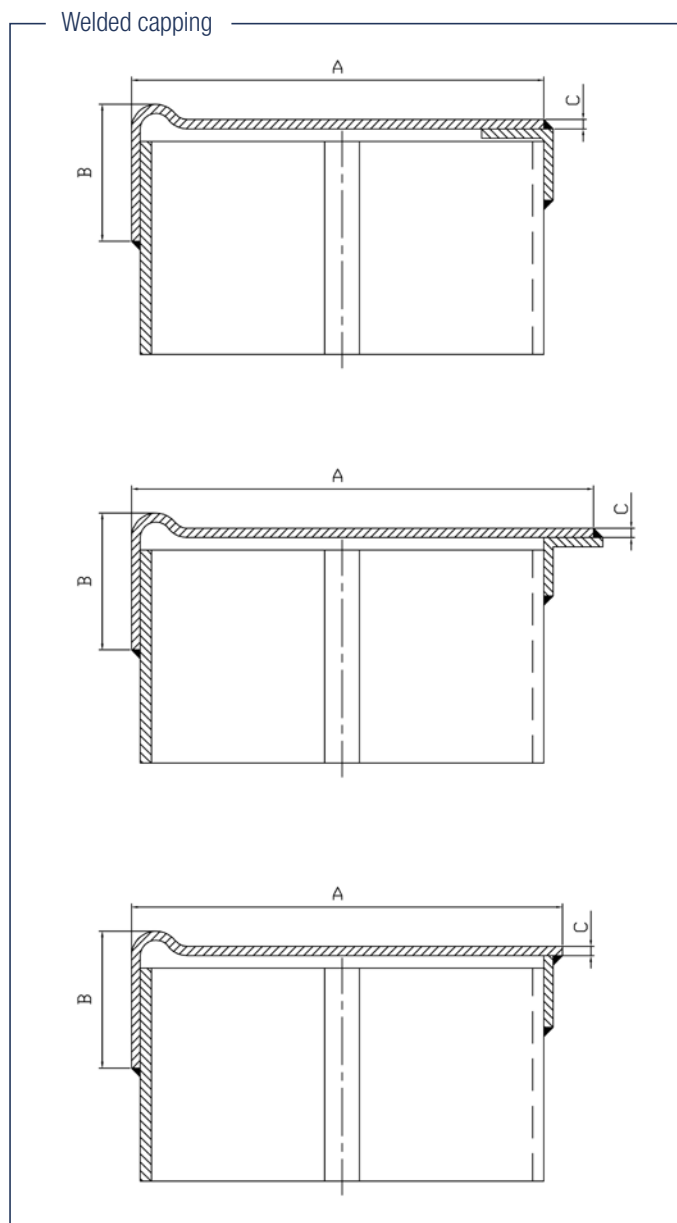

### Weight calculation:

$$(A+B-10) \times C \times \text{length} \times 0,785$$

Dims. A and B depend on sheet pile section and angle

Thickness C 8/10/12 mm

All forms can be fabricated with or without non-slip surface as required.

## Capping to concrete wall

Horizontal protective nosing

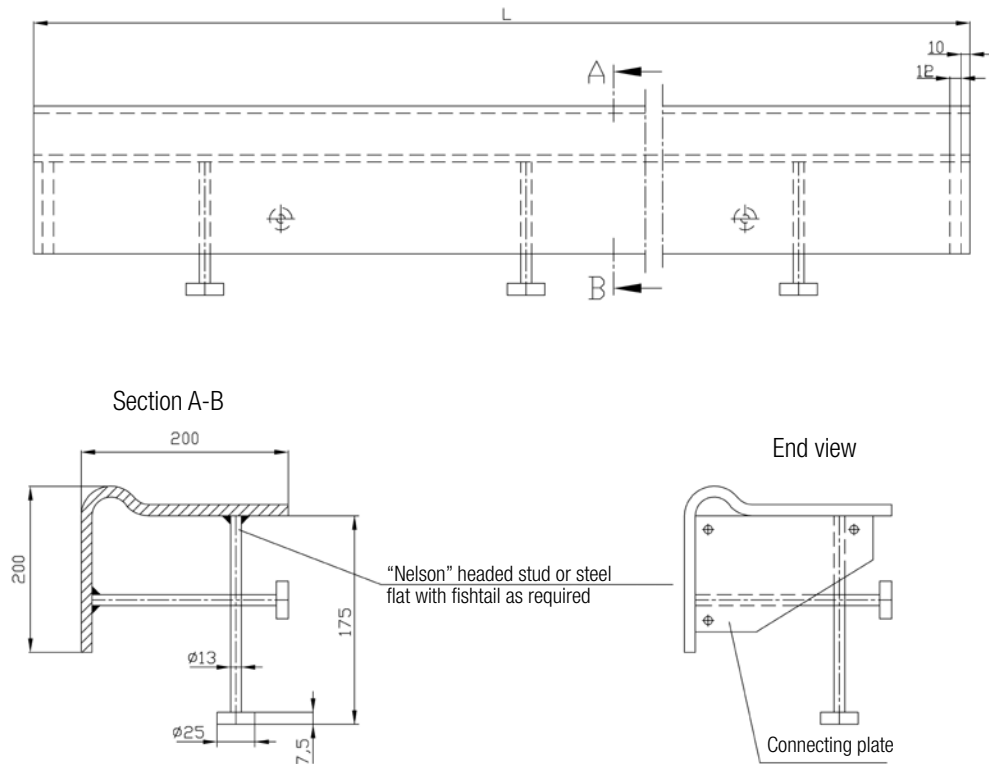

Vertical protective nosing

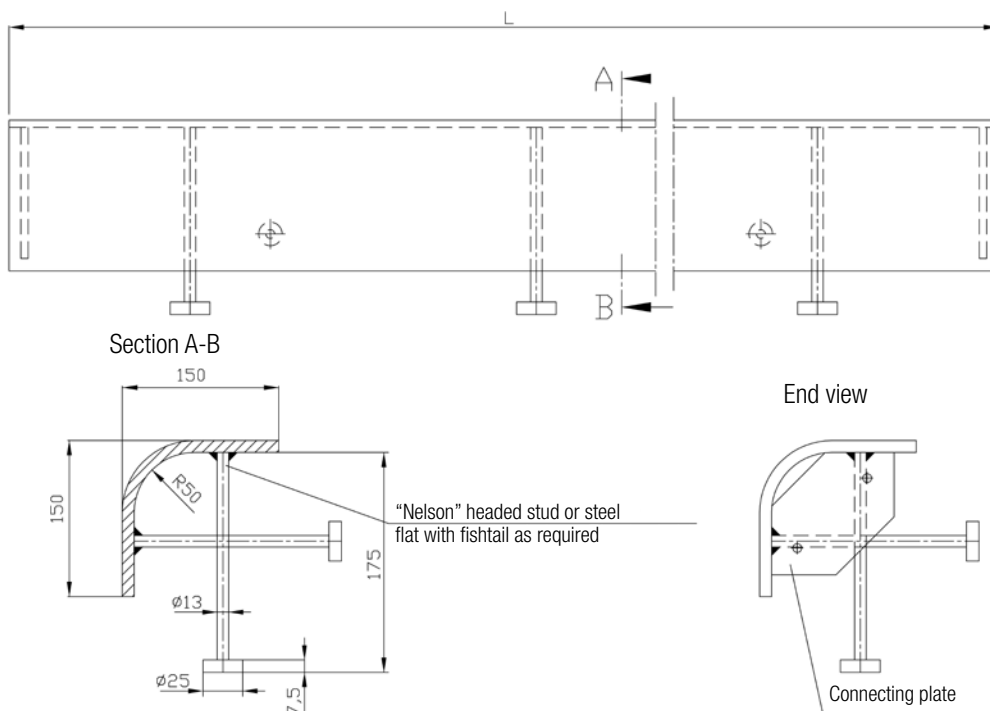

## Upper and lower nosing

Typical application

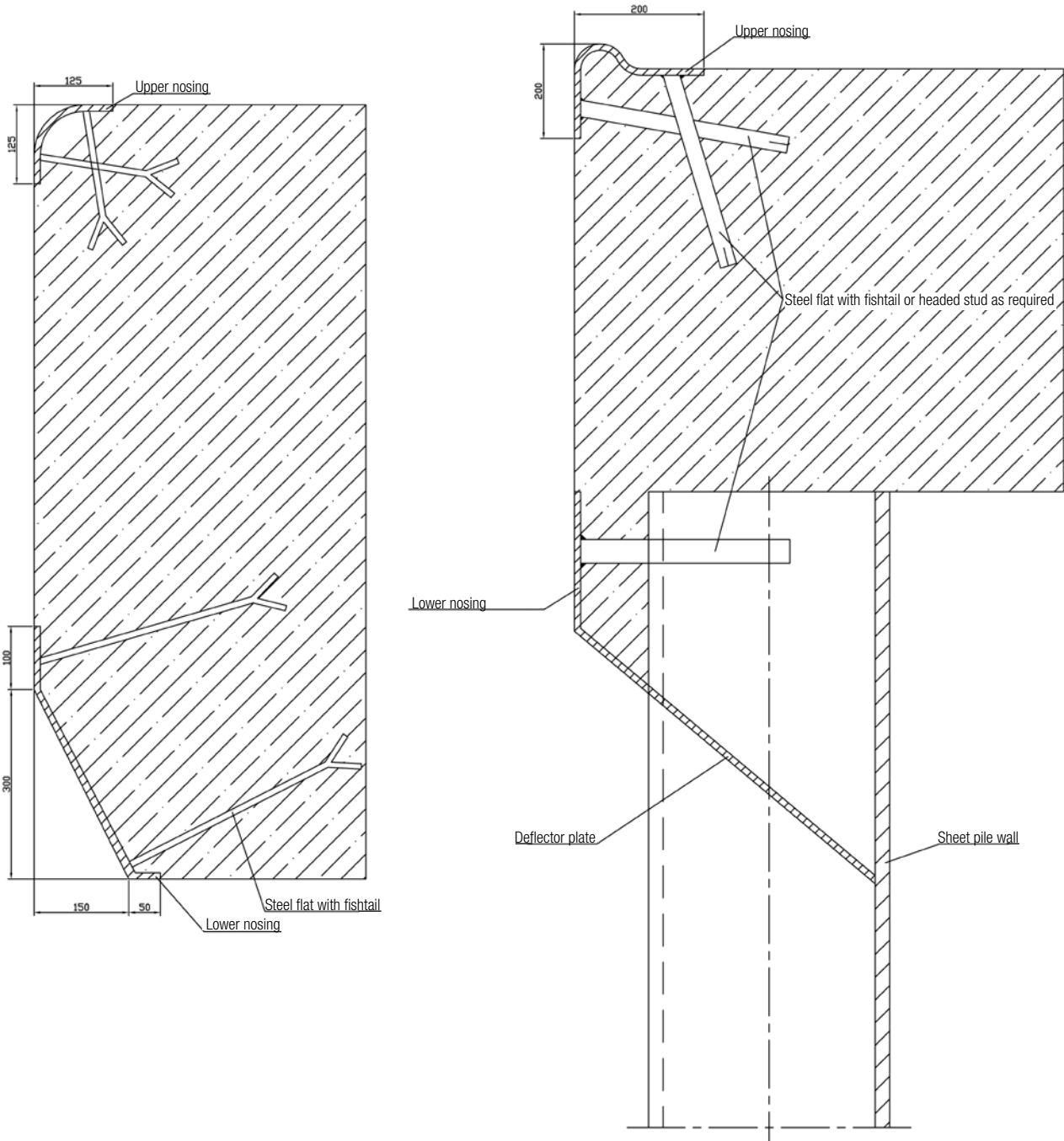

### Non-slip surface and ladder recesses

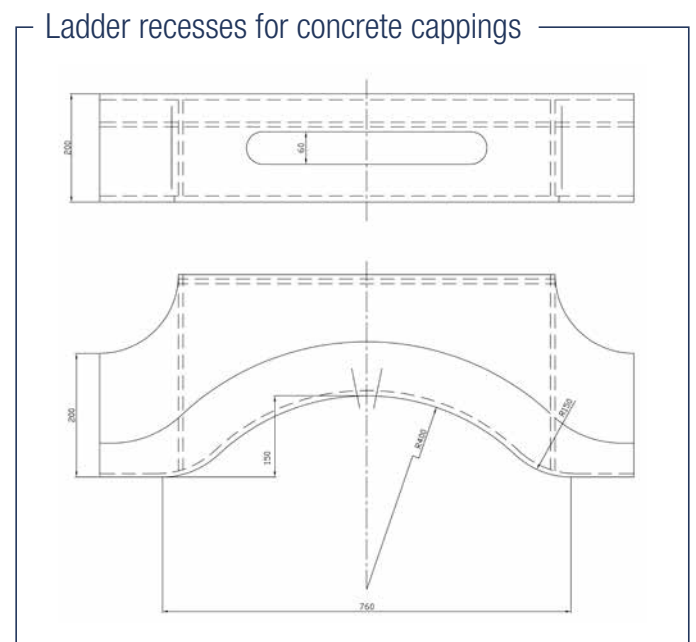
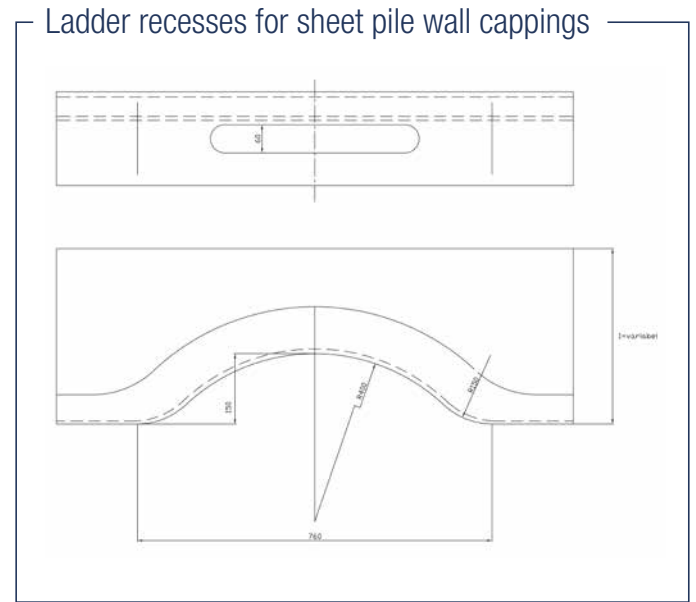
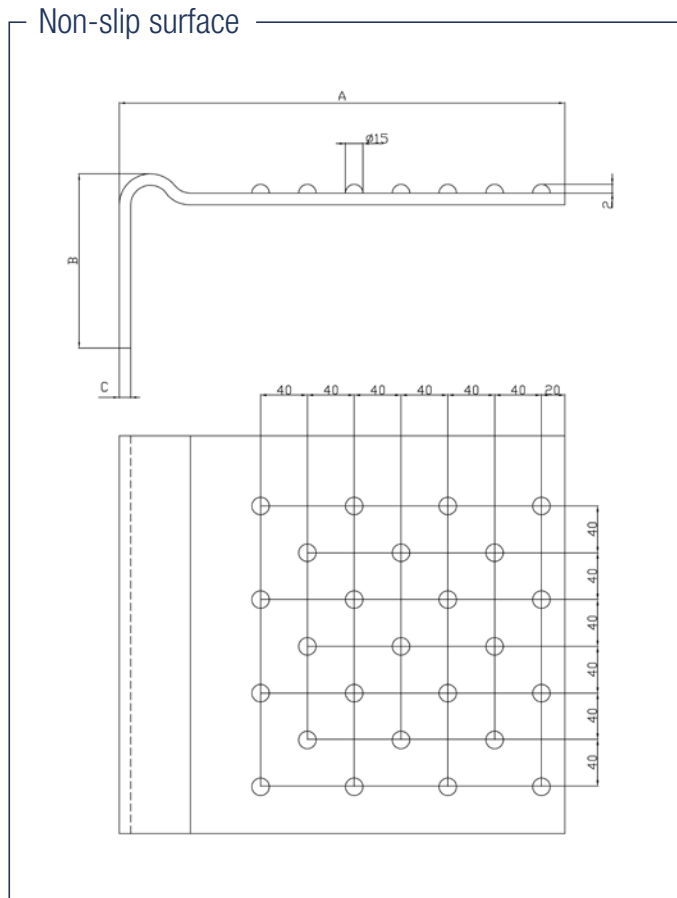

## Vertical ladders

Vertical ladders are mainly required to provide access to mooring facilities and to serve as a means of escape in emergencies. They must continue down to 1.00 m below the lowest anticipated (tidal) water level.

To make the ladders easy to install and replace, the lowest ladder fixing is in the form of a „plug-in“ connection. The capping beam is cut back behind the rungs at each ladder recess. In addition, a grab bar (40 mm diameter, 30 cm above quay level, 55 cm behind face of quay wall) must be fitted to all quay walls not liable to flooding.



Vertical ladder for quay walls

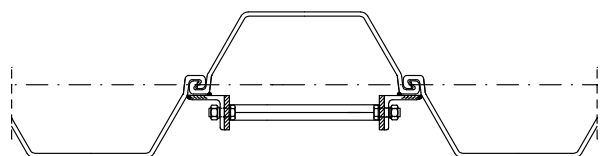
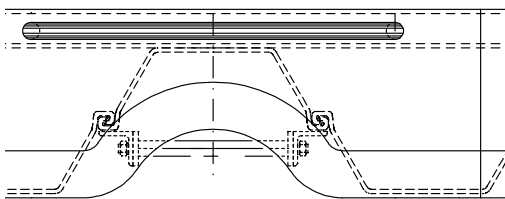
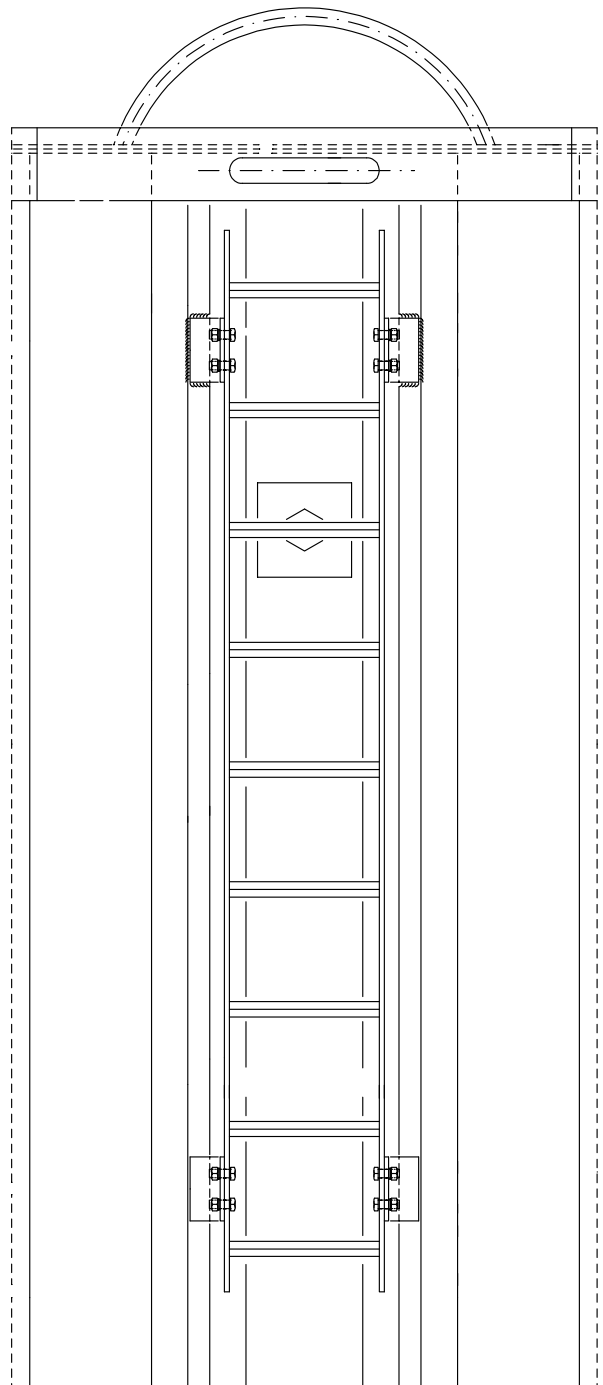
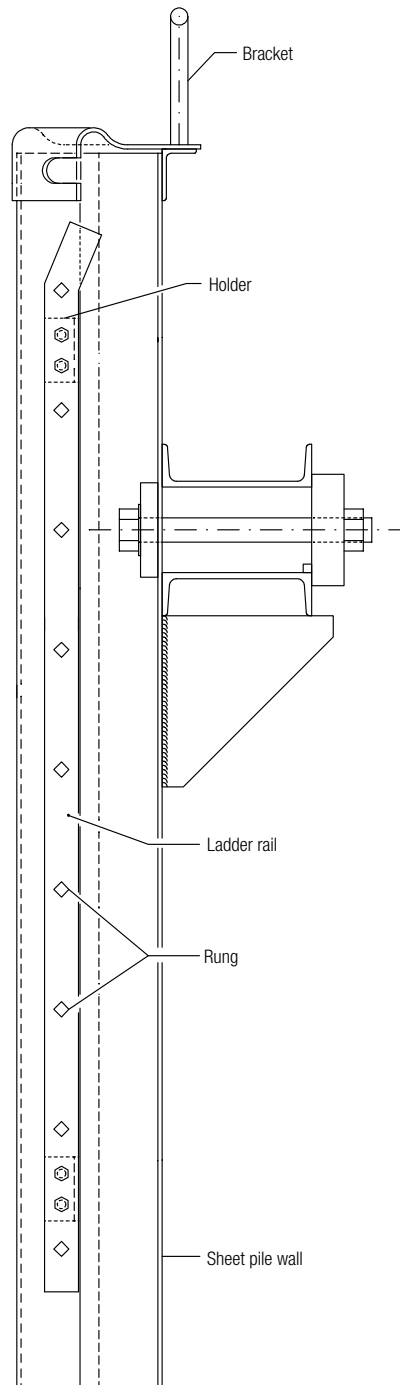

## Bollards

**Mooring facilities include edge bollards, mooring hooks, recessed bollards (for reinforced concrete walls), dolphin bollards, mooring rings, etc. All these items must be designed in such a way that they are easy to repair or replace.**

Bollards along the top edge of the quay wall can be provided in the form of single or double bollards depending on the line pull. They are made from high-quality grey cast iron or cast steel, with fixings made from grade S 355 J2 +N or 8.8. They can either be mounted on the top of a steel capping beam or anchored in a concrete foundation behind the beam. Depending on the design, they may need to be anchored back into the ground.



Single bollard

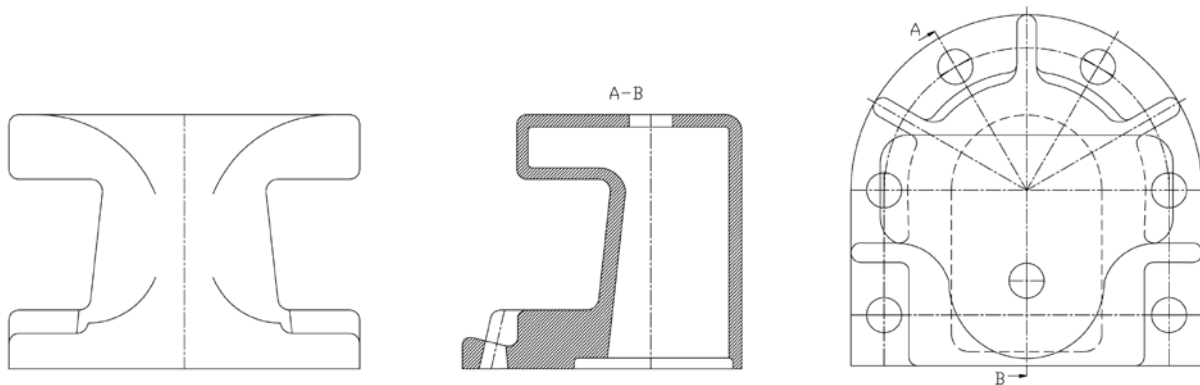

Double bollard

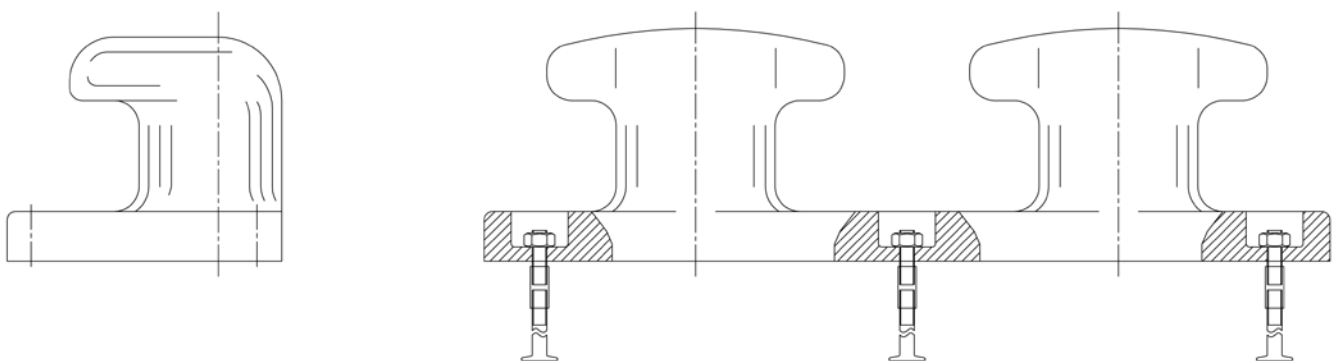



Break-off anchorages designed for the nominal load can be provided to avoid excessive line pull loads from overloading the sheet pile wall.

Apart from bollards along the top edge of the quay wall, it may be necessary to provide further bollards at various levels depending on the fluctuations in the local water levels alongside the sheet pile wall.

These mooring hooks are positioned one above the other in the trough of a sheet pile on both sides of a vertical ladder. They can be bolted or welded to the sheet pile. Mooring equipment on dolphins comes in the form of bollards mounted on the top or sides.



Recessed bollard for u- or Z-sections

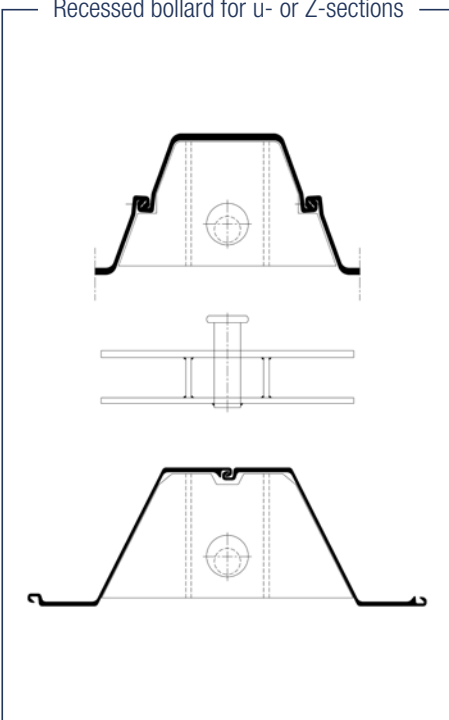

Top bollard for dolphins

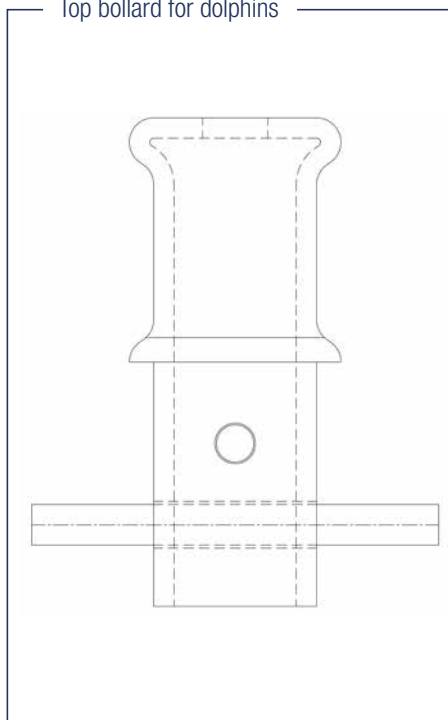

Side bollard for dolphins

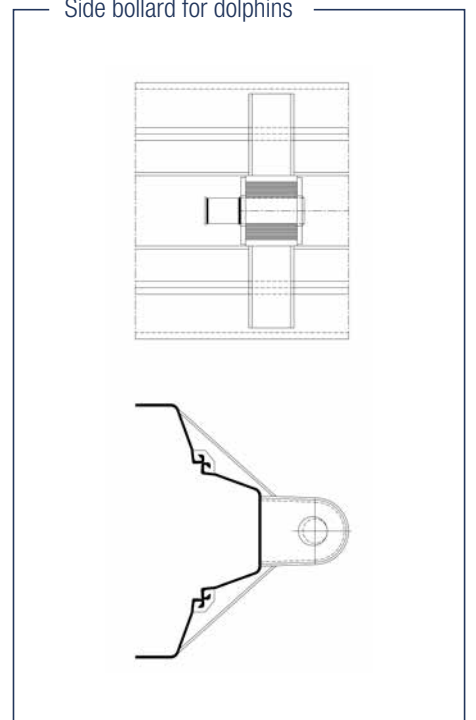

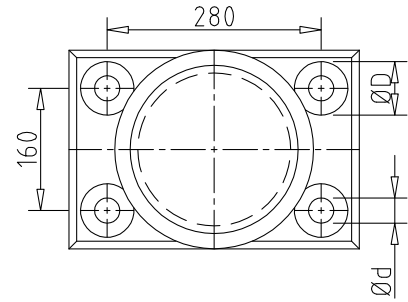
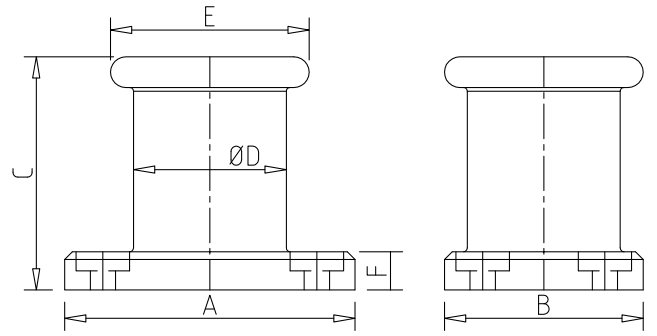

### 4-bolt bollard

Material: EN-GJL-250

Line pull (kN)	A (mm)	B (mm)	C (mm)	ØD (mm)	ØE (mm)	F (mm)
50	380	260	305	200	260	50
100	380	260	305	200	260	50

### Break-off anchorage for 4-bolt bollard

Material: Break-off bolt and socket by 50 kN in S355 and by 100 kN in ASF460

Line pull (kN)	Hole		Threaded anchor (mm)	Anchor bolt (mm)	Break-off bolt (mm)	Socket (mm)	Washer DIN7091
	Ød	ØD					
50	33	70	Ø30x550	Ø30x435	M30x102	45x100	33
100	33	70	Ø30x600	Ø30x485	M30x102	45x100	33



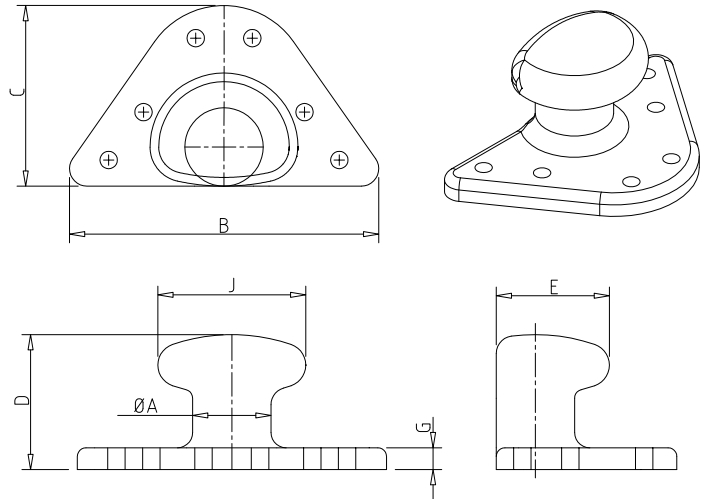

## Inland port bollard

Material: EN-GJL-250

Line pull	B	C	D	ØA	ØE	J	G	Weight	Material
(kN)	(mm)	(mm)	(mm)	(mm)	(mm)	(mm)	(mm)	(kg)	
50	710	415	300	180	260	340	40	93	EN-GJL-250
100	710	415	300	180	260	340	40	93	EN-GJL-250
150	710	415	300	180	260	340	40	93	EN-GJL-250
200	710	415	300	180	260	340	40	93	EN-GJL-250
300	710	415	300	180	260	340	55	122	EN-GJS-400-154

## Break-off anchorage for Inland port bollard

Line pull	Anchor	Threaded anchor			Break-off bolt		Socket		Notchnut	
		NG	IA	Øa	b	c	Øg	h	t	
(kN)		(mm)	(mm)	(mm)	(mm)	(mm)	(mm)	(mm)	(NG)	(mm)
50	4	M24	440	55	100	45	38	80	Ø76	20
100	4	M27	485	68	105	50	40	90	Ø76	20
150	6	M33	530	83	110	55	50	100	Ø76	20
200	6	M36	565	90	115	60	60	120	Ø76	20
300	6	M36	565	90	115	60	60	120	Ø76	20

## Standard anchorage for Inland port bollard

Line pull	Anchor	Threaded anchor			Notchnut	
		NG	IA	Øa	(NG)	t
(kN)		(mm)	(mm)	(mm)	(mm)	(mm)
50	4	M24	550	55	Ø76	20
100	4	M27	600	68	Ø76	20
150	6	M33	650	83	Ø76	20
200	6	M36	700	90	Ø76	20
300	6	M36	700	90	Ø76	20

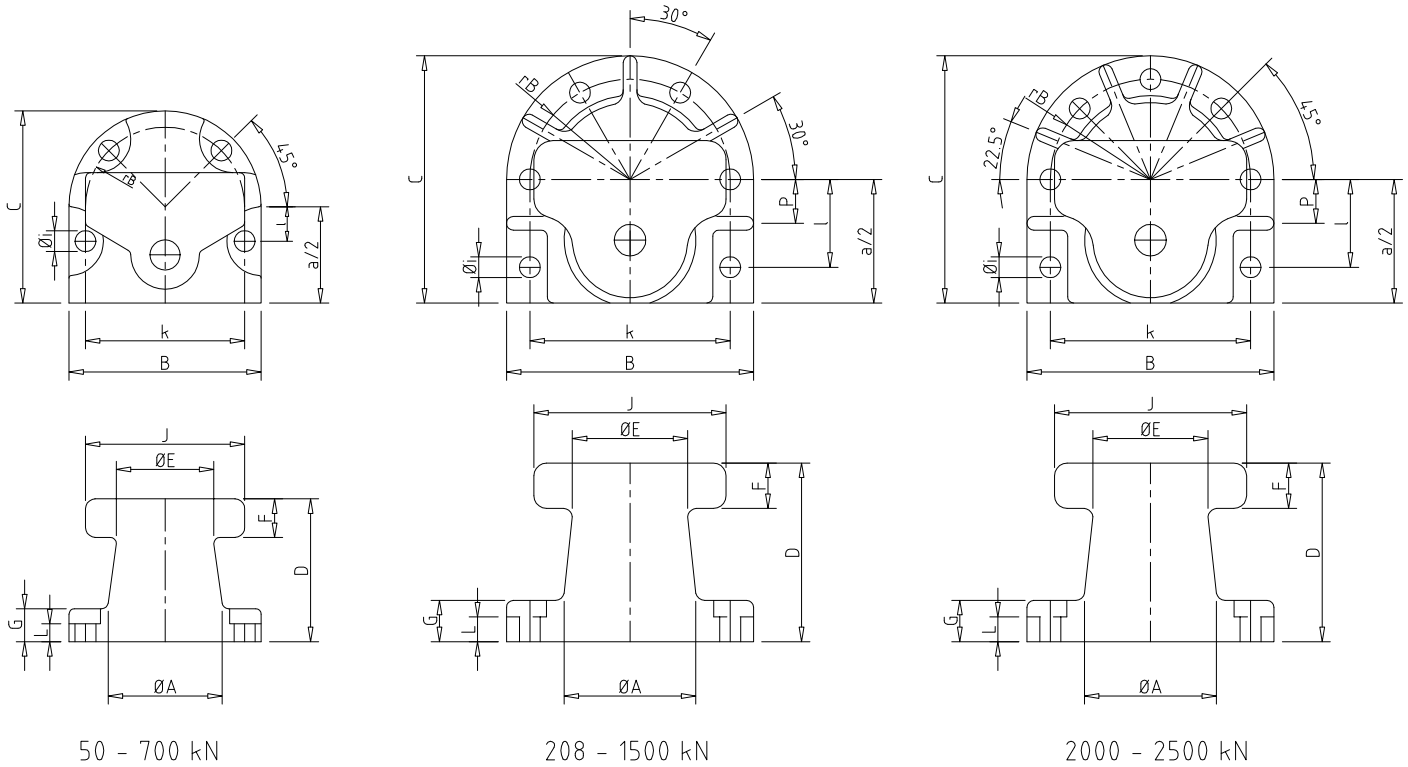

## Seaport bollard

Material: EN-GJL-250

Line pull (kN)	B (mm)	C (mm)	D (mm)	ØA (mm)	ØE (mm)	F (mm)	J (mm)	G (mm)	L (mm)	Øi (mm)	k (mm)	l (mm)	rB (mm)	P (mm)
50	400	400	310	230	190	80	330	60	30	29	320	75	160	
100	490	490	370	290	250	100	400	80	45	33	400	90	200	
150	590	590	410	330	280	110	480	90	50	39	500	100	250	
200	600	600	450	340	290	115	490	95	55	45	500	100	250	
300	640	640	500	380	325	125	530	115	60	58	510	130	255	
500	700	700	520	415	355	140	580	120	65	69	580	125	290	
600	820	900	560	450	380	130	650	120	70	75	650	340	325	
700	820	900	560	450	380	130	650	120	70	82	650	340	325	
800	900	900	650	480	420	165	760	150	90	75	750	320	365	160
1000	900	900	650	480	420	165	760	150	90	82	750	320	365	160
1250	1050	1050	800	545	465	250	820	160	90	90	850	350	425	180
1500	1100	1100	850	590	520	260	900	180	100	97	870	400	435	200
2000	1200	1200	900	640	580	290	960	220	120	105	950	420	475	210
2500	1250	1250	950	730	660	300	1000	230	130	110	1030	500	515	250



## Break-off anchorage for Seaport bollard

Line pull (kN)	Anchor	Threaded anchor		Thread		Plate	Break-off bolt			Socket		Total length	Nut	Washer
		ØD (mm)	$l_A$ (mm)	c (NG)	$l_g$ (mm)	Øa (mm)	b (mm)	c (mm)	e (mm)	Øg (mm)	h (mm)	m (mm)	DIN 4034 (NG)	DIN7091 (mm)
50	4	24	435	24	35	55	95	40	20	38	80	550	M24	26
100	4	27	440	27	40	68	120	50	25	40	90	580	M27	30
150	4	33	495	33	45	83	135	60	20	50	100	650	M33	36
200	4	36	520	36	50	98	160	75	25	60	120	700	M36	39
300	4	52	605	52	60	120	195	95	30	80	150	820	M52	56
500	4	56	690	56	70	145	220	105	35	90	170	930	M56	62
600	4	64	760	64	90	160	240	115	40	100	210	1040	M64	70
700	4	72	805	72	90	180	255	125	40	105	220	1100	M72	78
800	6	64	820	64	90	160	260	120	50	100	210	1120	M64	70
1000	6	72	805	72	90	180	275	130	50	105	220	1120	M72	78
1250	6	76	890	76	100	190	290	140	50	115	240	1220	M76	78
1500	6	85	980	85	110	205	320	155	50	125	260	1340	M85	91
2000	7	90	1065	90	110	225	355	170	60	140	270	1460	M90	96
2500	7	95	1255	95	120	238	385	180	70	150	290	1680	M95	100

### Anchorage / Break-off anchorage for bollards

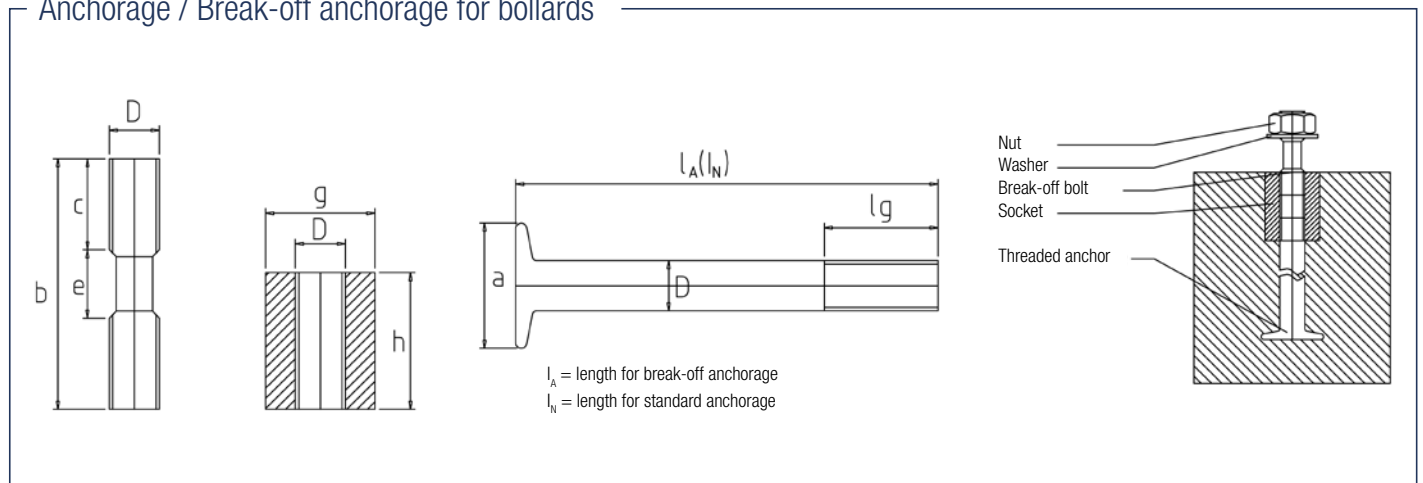

## Dolphins

**In engineering terms, a dolphin is a pile or group of piles with fixity in the bed of the watercourse and subjected to a horizontal load. The bed of the watercourse is generally the in situ soil, the critical horizontal load mostly caused by the impact of a vessel.**

Dolphins vary in terms of their construction and function and can be basically divided into two groups depending on their purpose:

- Breasting dolphins: used for berthing, guiding and deflecting vessels and marking navigation channels. These dolphins must be as elastic as possible to prevent damaging vessels. Large impact loads are resisted by the deformation work of the dolphin and the subsoil.
- Mooring dolphins: used for mooring and hauling. A rigid design is more suitable for this type of dolphin. A rigid dolphin is also advantageous when casting-off.

The difference between breasting and mooring dolphins is the way they are measured. Breasting dolphins are designed for the berthing pressure of a vessel (direct impact), whereas mooring dolphins are designed for the line pull of hawsers.

In Germany in particular, dolphins are constructed from sheet pile materials. Such dolphins are assembled from between two and eight sheet pile sections that are welded together over their entire length. Another variation is the dolphin made from a single tubular section – with thick wall and large outside diameter.

Depending on their function, dolphins are equipped with bollards on the top and sides, mooring hooks or recessed bollards, ladders and plates to resist impacts.

**We fabricate all attachments ourselves and weld them to the dolphins. Upon request, dolphins can be coated in our works.**



Elevation om breasting dolphin from water side

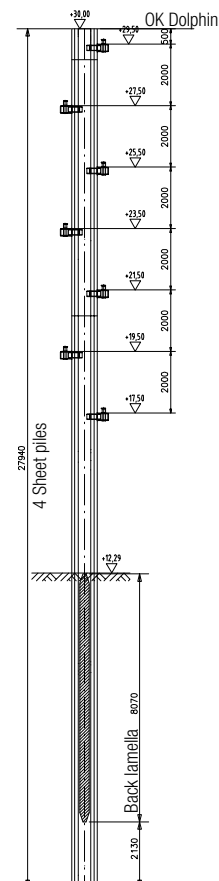





## Gangways, steps and stairs

We have fabrication facilities for building gangways, steps and stairs to customer specifications and drawings. We of course supply all gangways, steps and stairs complete with balustrades, handrails and open-grid flooring – untreated, hot-dip galvanised or coated to customer specification.

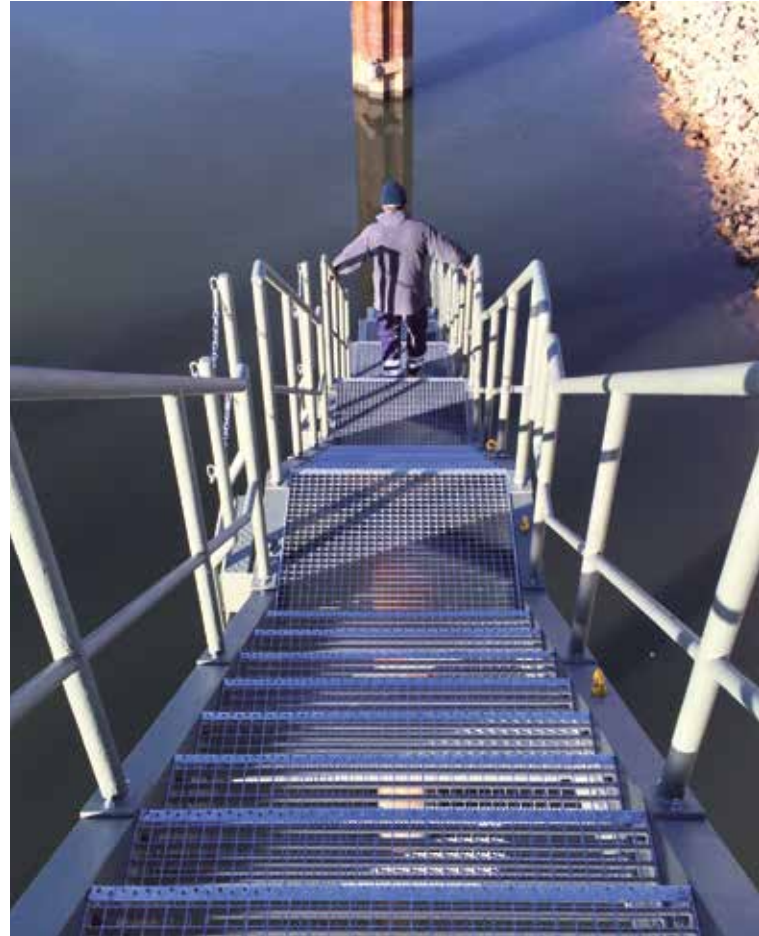

















## Weight table kg/m

Round steel bar 5 - 220 mm DIN EN 10060  
 Square steel bar 5 - 150 mm DIN EN 10059  
 Hexagonal steel bar 10 - 103 mm DIN EN 10061

$\emptyset$ mm			
5	0.15	0.20	0.17
6	0.22	0.28	0.25
7	0.30	0.39	0.33
8	0.40	0.50	0.44
9	0.50	0.64	0.55
10	0.67	0.79	0.68
11	0.75	0.95	0.82
12	0.89	1.13	0.98
13	1.04	1.33	1.15
14	1.21	1.54	1.33
15	1.39	1.77	1.53
16	1.58	2.01	1.74
17	1.78	2.27	1.97
18	2.00	2.54	2.20
19	2.23	2.83	2.45
20	2.47	3.14	2.72
21	2.72	3.46	3.00
22	2.98	3.80	3.29
23	3.26	4.14	3.60
24	3.55	4.52	3.92
25	3.85	4.91	4.25
26	4.17	5.31	4.60
27	4.50	5.72	4.96
28	4.83	6.15	5.33
29	5.19	6.60	5.72
30	5.55	7.07	6.12
31	5.93	7.54	6.53
32	6.31	8.04	6.96
33	6.71	8.55	7.40
34	7.13	9.08	7.86
35	7.55	9.62	8.33
36	7.99	10.20	8.81
37	8.44	10.75	9.31
38	8.90	11.34	9.82
39	9.38	11.94	10.34
40	9.87	12.56	10.88
41	10.36	13.20	11.43
42	10.88	13.85	11.99
43	11.40	14.52	12.57
44	11.94	15.20	13.16

$\emptyset$ mm			
45	12.49	15.90	13.77
46	13.05	16.61	14.39
47	13.62	17.34	15.02
48	14.21	18.09	15.66
49	14.80	18.85	16.32
50	15.41	19.63	17.00
51	16.04	20.42	17.68
52	16.62	21.23	18.38
53	17.32	22.05	19.10
54	17.98	22.89	19.82
55	18.66	23.75	20.57
56	19.34	24.62	21.32
57	20.03	25.51	22.09
58	20.74	26.41	22.87
59	21.46	27.33	23.67
60	22.20	28.26	24.47
61	22.94	29.21	25.30
62	23.70	30.18	26.13
63	24.47	31.16	26.98
64	25.25	32.15	27.85
65	26.05	33.17	28.72
66	26.86	34.20	29.61
67	27.68	35.24	30.52
68	28.51	36.30	31.44
69	29.35	37.37	32.37
70	30.21	38.46	33.30
71	31.08	39.57	34.27
72	31.96	40.69	35.24
73	32.86	41.83	36.23
74	33.76	42.99	37.23
75	34.68	44.16	38.24
76	35.61	45.34	39.27
77	36.56	46.54	40.31
78	37.51	47.76	41.36
79	38.48	48.99	42.43
80	39.46	50.24	43.51
81	40.45	51.50	44.60
82	41.46	52.78	45.71
83	42.47	54.08	46.83
84	43.50	55.39	47.97

$\emptyset$ mm			
85	44.55	56.72	49.12
86	45.60	58.05	50.28
87	46.67	59.42	51.46
88	47.75	60.79	52.65
89	48.84	62.18	53.85
90	49.94	63.58	55.07
91	51.06	65.01	56.30
92	52.18	66.44	57.54
93	53.32	67.90	58.80
94	54.48	69.36	60.07
95	55.64	70.85	61.36
96	56.82	72.35	62.56
97	58.01	73.86	63.96
98	59.21	75.39	65.29
99	60.43	76.94	66.63
100	61.65	78.50	67.98
102	64.15	81.67	70.73
104	66.68	84.91	73.53
105	67.94	86.55	74.95
106	69.27	88.20	76.39
108	71.91	91.56	79.30
110	74.60	94.98	82.26
112	77.34	98.47	85.28
114	80.13	102.02	88.35
115	81.50	103.82	89.90
116	82.96	105.63	91.48
118	85.85	109.30	94.66
120	88.78	113.04	97.90
122	91.77	116.84	101.19
124	94.80	120.70	104.53
125	96.29	122.66	106.22
126	97.88	124.63	107.93
128	101.01	128.61	111.38
130	104.00	132.66	114.89
132	107.43	136.78	118.45
134	110.71	140.96	122.07
135	112.31	143.07	123.90
136	114.04	145.19	125.74
138	117.41	149.50	129.47
140	121.00	153.86	133.25

## Weight table kg/m

Round steel bar 5 - 220 mm DIN EN 10060  
 Square steel bar 5 - 150 mm DIN EN 10059  
 Hexagonal steel bar 10 - 103 mm DIN EN 10061

Ø mm			
	Round	Square	Hexagonal
142	124.32	158.29	137.08
144	127.85	162.78	140.97
145	129.56	165.05	142.93
146	131.42	167.33	144.91
148	135.05	171.95	148.91
150	138.70	176.60	153.00
152	142.40	181.40	157.10
154	146.20	186.20	161.20
155	148.10	188.60	163.30
156	150.00	191.00	165.40
158	153.90	196.00	169.70
160	157.80	201.00	174.00
162	161.80	206.00	178.40
164	165.80	211.10	182.80
165	167.80	213.70	185.10
166	169.90	216.30	187.30
168	174.00	221.60	191.90
170	178.00	226.90	196.50
172	182.40	232.20	201.10
174	186.70	237.70	205.80
175	188.70	240.40	208.20
176	191.00	243.20	210.60
178	195.30	248.70	215.40
180	199.80	254.30	220.30
182	204.20	260.00	225.20
184	208.70	265.80	230.20
185	210.90	268.70	232.70
186	213.30	271.60	235.20
188	217.90	277.40	240.30
190	222.60	283.40	245.40
192	227.30	289.40	250.60
194	232.00	295.40	255.90
195	234.30	298.50	258.50
196	236.00	301.60	261.20
198	241.70	307.80	266.50
200	246.60	314.00	271.90
205	259.10	329.90	285.70
210	271.90	346.20	299.80
215	285.00	362.90	314.30
220	298.40	379.90	329.00

Ø mm			
	Round	Square	Hexagonal
225	312.10	400.90	344.20
230	326.20	415.30	359.60
235	340.50	433.50	375.40
240	355.10	452.20	391.60
245	370.10	471.20	408.10
250	385.30	490.60	424.90
255	400.90	510.40	442.10
260	416.80	530.70	459.60
265	433.00	551.30	477.40
270	449.50	572.30	495.80
275	466.30	593.70	514.10
280	483.40	615.40	533.00
285	500.80	637.50	552.20
290	518.50	660.20	571.70
295	536.50	683.10	591.60

Ø mm			
	Round	Square	Hexagonal
300	554.90	706.50	611.80
305	573.50	730.20	632.40
310	592.50	754.40	653.30
315	611.80	778.90	674.60
320	631.30	803.80	696.10
325	651.20	829.20	718.10
330	671.40	854.90	740.30
335	681.90	881.00	762.90
340	712.70	907.50	785.90
345	733.80	934.30	809.20
350	755.30	961.60	832.80
400	986.50	1.256.00	1.087.70
450	1.248.50	1.589.60	1.376.70
500	1.541.40	1.962.50	1.699.60
1000	6.165.40	7.850.00	6.798.30

## Standard channel sections (UNP)

U-Profil 80 - 400 mm DIN 1026

Designation	Depth	Width	Web thickness	Flange thickness	Weight
	h	b	s	t	
U80	80	45	6.0	8.0	8.9
U100	100	50	6.0	8.5	10.9
U120	120	55	7.0	9.0	13.7
U140	140	60	7.0	10.0	18.4
U160	160	65	7.5	10.5	19.3
U180	180	70	8.0	11.0	22.5
U200	200	75	8.5	11.5	25.3
U220	220	80	9.0	12.5	29.4
U240	240	85	9.5	13.0	34.0
U260	260	90	10.0	14.0	39.0
U280	280	95	10.0	15.0	43.0
U300	300	100	10.0	16.0	48.0
U320	320	100	14.0	17.5	61.0
U350	350	100	14.0	16.0	62.0
U380	380	102	13.5	19.0	64.0
U400	400	110	14	18.0	74.0

## List of standards and directives used by us

<b>DIN 976-1</b>	Stud bolts – Part 1: Metric thread
<b>DIN 19703</b>	Locks for waterways for inland navigation – Principles for dimensioning and equipment
<b>DIN 1054</b>	Subsoil – Verification of the safety of earthworks and foundations – Supplementary rules to DIN EN 1997-1
<b>DIN EN 1090-1</b>	Execution of steel structures and aluminium structures – Part 1: Requirements for conformity assessment of structural components
<b>DIN EN 1090-2</b>	Execution of steel structures and aluminium structures – Part 2: Technical requirements for steel structures
<b>DIN 1478</b>	Turnbuckles made from steel tubes or round steel bars
<b>DIN EN 1537</b>	Execution of special geotechnical work – Ground anchors
<b>DIN EN 1561</b>	Founding – Grey cast irons
<b>DIN EN 1563</b>	Founding – Spheroidal graphite cast irons
<b>DIN EN 1993-1-1</b>	Eurocode 3: Design of steel structures – Part 1-1: General rules and rules for buildings
<b>DIN EN 1993-1-1/NA</b>	National Annex – Nationally Determined Parameters Eurocode 3: Design of steel structures – Part 1-1: General rules and rules for buildings
<b>DIN EN 1993-1-5</b>	Eurocode 3: Design of steel structures – Part 1-5: Plated structural elements
<b>DIN EN 1993-1-5/NA</b>	National Annex – Nationally Determined Parameters Eurocode 3: Design of steel structures – Part 1-5: Plated structural elements
<b>DIN EN 14199</b>	Execution of special geotechnical works – Micropiles
<b>DIN EN 10025-2</b>	Hot-rolled products of structural steels – Part 2: Technical delivery conditions for non-alloy structural steels
<b>DIN EN 10027-1</b>	Designation systems for steels – Part 1: Steel names
<b>DIN EN 10059</b>	Hot-rolled square steel bars for general purposes – Dimensions and tolerances on shape and dimensions
<b>DIN EN 10060</b>	Hot-rolled round steel bars – Dimensions and tolerances on shape and dimensions
<b>DIN EN 10061</b>	Hot-rolled hexagon steel bars – Dimensions and tolerances on shape and dimensions
<b>DIN EN 10279</b>	Hot-rolled steel channels – Tolerances on shape, dimensions and mass
<b>DIN 19704-1</b>	Hydraulic steel structures – Part 1: Criteria for design and calculation
<b>DIN 19704-2</b>	Hydraulic steel structures – Part 2: Design and manufacturing
<b>DIN EN ISO 4016</b>	Hexagon head bolts – Product grade C
<b>DIN EN ISO 8062-3</b>	Geometrical Product Specifications (GPS) – Dimensional and geometrical tolerances for moulded parts – Part 3: General dimensional and geometrical tolerances and machining allowances for castings
<b>DIN EN ISO 9001</b>	Quality management systems – Requirements
<b>DIN EN ISO 9013</b>	Thermal cutting – Classification of thermal cuts – Geometrical product specification and quality tolerances
<b>EAU 2012</b>	Recommendations of the Committee for Waterfront Structures, Harbours and Waterways, EAU 2012
<b>BS OHSAS 18001</b>	Occupational health and safety management systems – Requirements
<b>DIN EN ISO 12944-1</b>	Paints and varnishes – Corrosion protection of steel structures by protective paint systems – Part 2: Classification of environments
<b>DIN EN ISO 3834-2</b>	Quality requirements for fusion welding of metallic materials – Part 2: Comprehensive quality requirements
<b>DIN EN 1993-5</b>	Eurocode 3: Design of steel structures – Part 5: Piling
<b>DIN EN 1997-1</b>	Eurocode 7: Geotechnical design – Part 1: General rules
<b>DIN EN 10025-6</b>	Hot-rolled products of structural steels – Part 6: Technical delivery conditions for flat products of high yield strength structural steels in the quenched and tempered conditions
<b>DIN EN 15048-1</b>	Sets for non-pretensioned screw connections in metal construction - Part 1: General requirements
<b>DIN 2768-1</b>	General tolerances-Tolerances for linear and angular dimensions without individual tolerance indications (Deviations in the forging area up to 3 %)

## Completed project: Scaldiahaven, Netherlands

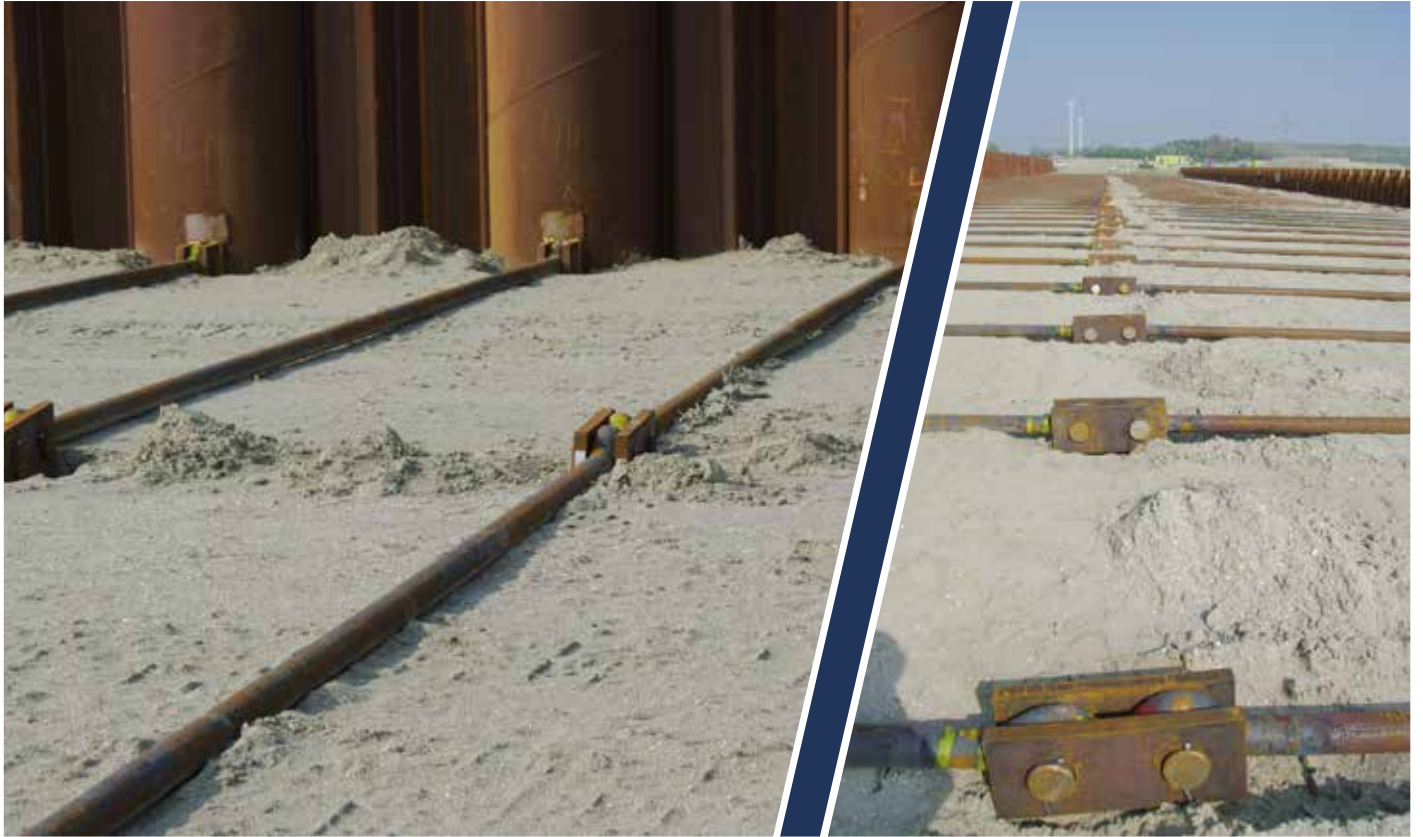

**Completed project: Piombino 1-2, Italia**



## Completed project: Strelasundquerung, Rügen, Germany



## Completed project: Weserschleuse Minden, Germany





## Completed project: Schwelgern, Germany



## Completed project: Trier, Germany



**Completed project: Jade Weser Port, Wilhelmshaven, Germany**







## Contact...



**Im Braukhausiepen 7**  
**Industriegebiet Braukessiepen**  
**58802 Balve | Germany**  
**Fon: +49 (0) 2375 9186-0**  
**Fax: +49 (0) 2375 5980**  
**mail@asf-anker.de**  
**www.asf-anker.de**

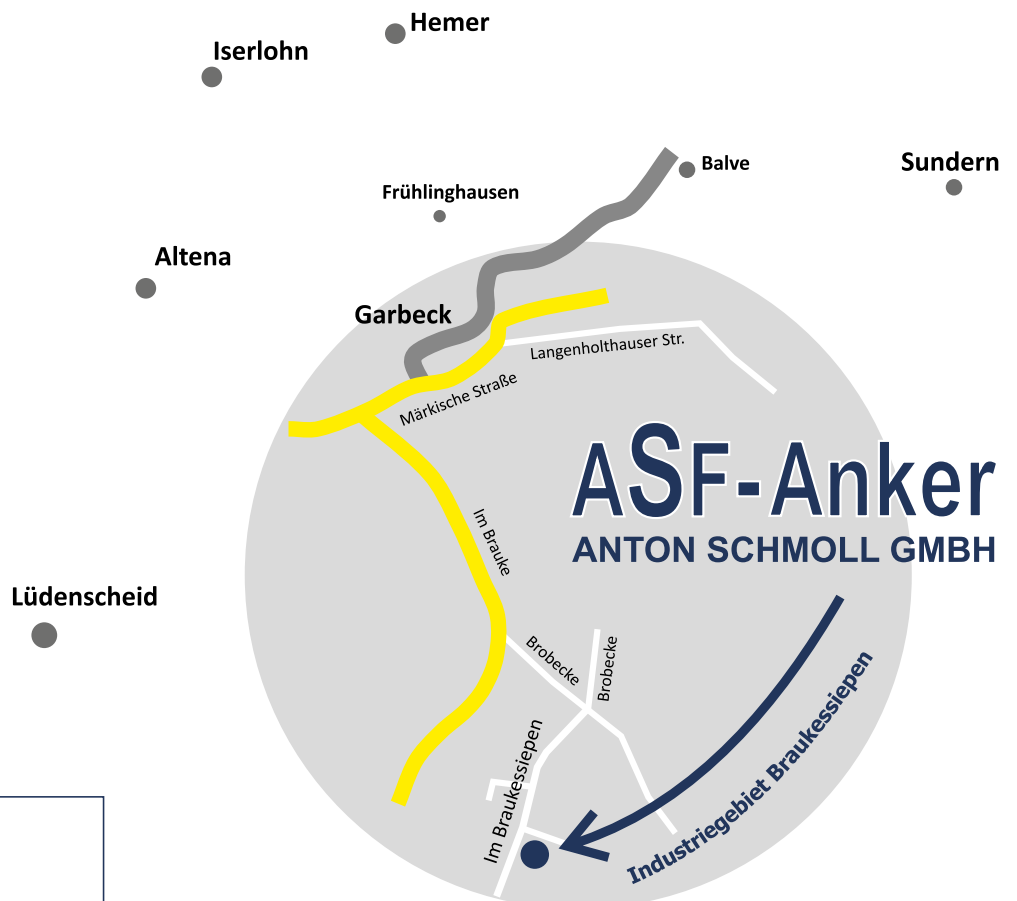

Help for your Sat Nav!  
 Street: Im Kirchfeld

# ASF-Anker

ANTON SCHMOLL GMBH

**Connection solutions for steelwork, buildings,  
plants and hydraulic engineering**

Im Braukhausiepen 7 | Industriegebiet Braukessiepen | 58802 Balve | Germany  
Fon: +49 (0) 2375 9186-0 | Fax: +49 (0) 2375 5980  
mail@asf-anker.de | www.asf-anker.de  
www.facebook.com/asf-anker anton schmoll gmbh  
www.youtube.com/user/asfankergmbh

